

# FunSicle®

# Sand Filter Pump

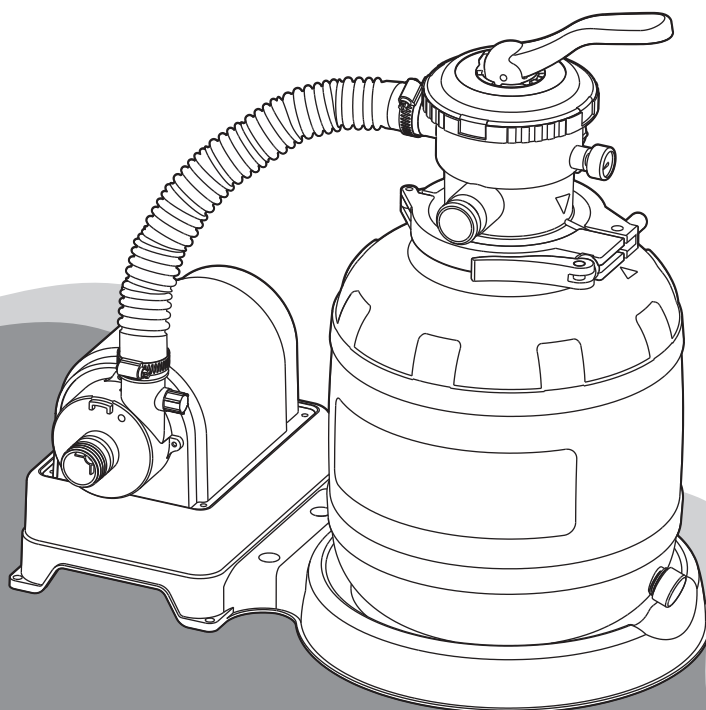

## User Guide

Simple steps to setting up and enjoying your pool pump



Sign up for future  
offers and discounts.  
Scan the QR Code.

# Contents

Welcome! .....	3
Warranty Information .....	3
Safety Guidelines .....	4
Warnings .....	4
Before You Begin .....	10
Preliminary Steps .....	10
Filter Pump Power Specifications .....	10
Parts List .....	11
Setting Up the Sand Filter Pump .....	13
STEP 1: Install the Suction & Return Fittings .....	13
STEP 2: Install the Sand Filter Pump .....	14
Using the Pump .....	19
Before using the Pump .....	19
Use the Pump .....	20
GFCI Plug Instructions .....	21
Pump Motor Care .....	22
Maintaining the Pump .....	22
Caring for Your Pool .....	22
Winterizing, Disassembly & Storage .....	23
Troubleshooting Guide .....	24
6-port Valve Parts List .....	26
6-port Valve Setup .....	27
ASME Compliant Suction Fitting Information .....	29

# Welcome!

---

Congratulations on your new Funsicle Sand Filter Pump – the easiest way to enjoy constant clean pool water. This guide will walk you through everything from setting up to maintaining and enjoying your filter pump.

As always, we're here to help. For any issues, questions, or extra support, visit [funsicle.com/support](https://funsicle.com/support), or contact Customer Service at 888-670-4FUN (888-670-4386) or [HelloFun@Funsicle.com](mailto>HelloFun@Funsicle.com).

Learn more about us at [Funsicle.com](https://Funsicle.com)

## Warranty Information

---

This Funsicle Sand Filter Pump is subject to the following warranty, with warranty service provided by Polygroup Services N.A., Inc. (hereinafter "Polygroup" or "PSNA").

### Limited Warranty

PSNA is pleased to offer this warranty for the repair or replacement of Electric Filter Pumps for one (1) year from the date of purchase. The provisions of this Limited Warranty only apply to the original purchaser and who purchased from an authorized Polygroup seller. Please keep your original store sales receipt. This proof of purchase will be required and must accompany warranty claims to PSNA or its designated agents. This Limited Warranty also will not apply to modified or repaired products, unless authorized by PSNA in writing; or to products in which non-Polygroup parts or accessories were substituted; or use of the product in contravention of the product's instructions; or when improper voltage was used; or if the product was abused, or harmed through accident or negligence. This Limited Warranty does not cover consequential damages, including, but not limited to, claims for loss of water, pool chemicals, or labor time or costs, normal wear-and-tear; nor to acts of God, nor to damage to any other products or property.

In no event shall Polygroup, its authorized agents, related entities, or employees be liable to the buyer or any other party for direct or consequential damages. This limitation, in part or in full, may not apply to you, if the jurisdiction in which the claim arose does not allow this limitation.

This Limited Warranty is not extended to close-outs, factory seconds, or resold products, such as garage sales or auctions, or purchases from non-authorized sellers of Polygroup products. This Warranty also does not apply to online vendors or any other sellers who did not purchase the products from a Polygroup company, whether the product has been used or not prior to being sold to you. Any issues with items purchased from these types of vendors/sellers will need to be addressed directly with them.

# Safety Guidelines

## IMPORTANT SAFETY INSTRUCTIONS

When installing and using this electrical equipment, basic safety precautions should always be followed, including the following:

## READ AND FOLLOW ALL INSTRUCTIONS

**Keep this User Guide for future reference. Failure to follow these warnings and instructions can result in serious injury or death to users, especially children.**

### Warnings

#### ▲ WARNING:

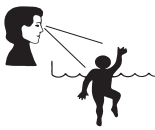

##### PREVENT DROWNING!

- Closely watch children who are in or near this pool.
- Children under 5 are at highest risk for drowning.
- Do not leave child unattended while in use.
- Use only under competent supervision.
- Empty the pool or prevent access when not in use.



##### NO DIVING!

You can break your neck and be paralyzed.



##### AVOID ENTRAPMENT!

- Stay away from drains & suction fittings, your hair, body, & jewelry can get sucked into drain. You could be held under water & drown.
- Do not use pool if drain or suction outlet cover is missing or broken.



##### DO NOT SIT ON OR LAY OVER POOL WALL

Install a pool fence around the pool to prevent children from gaining unauthorized access and drowning. State or local codes may require fencing and other safety measures (not included), such as a pool alarm. Consult local building code officials for requirements.

Read and follow all safety information and assembly instructions in the User Guide.

**NOTICE:** Customers who purchase pools may be required by local or state law to incur additional expenses when installing a pool, in order to comply with state or local laws regarding fencing and other safety requirements. Customers should contact their local building code enforcement office for further details. Polygroup is not responsible for any additional expenses that you may incur.

## SAFETY CARE FOR CHILDREN

- Children, especially children younger than five years, are at high risk of drowning. Drowning occurs silently and quickly and can occur in as little as 2 in (5 cm) of water.
- Keep children in your direct sight, stay close, and actively supervise them when they are in or near this pool and when you are filling and emptying this pool.
- When searching for a missing child, check the pool first, even if the child is thought to be in the house.
- Locate pumps and filters in such a way that children cannot climb on them and gain access to the pool.
- **WARNING:** To reduce the risk of injury, do not permit children to use this product unless they are closely supervised at all times.

## SWIMMING POOL BARRIERS

### Important:

Swimming pool barriers, which restrict access to the pool by small children, may be required by law. A barrier is necessary to provide protection against potential drowning and near drowning. Barriers are not a substitute for constant supervision of children. Check state or local laws and codes before setting up the pool.

## SWIMMING POOL EQUIPMENT

- The use of artificial pool lighting is at the discretion of the pool owner. Lighting, when installed, should be in accordance with Article 680 of the National Electrical Code (NEC®) or its latest approved edition and in consultation with a licensed electrical professional.
- Keep all electrical lines, radios, speakers, and other electrical appliances away from the pool.
- Do not place the pool near or under overhead electrical lines.
- All electrical components installed in and/or adjacent to an above-ground/on-ground residential swimming pool shall be installed in accordance with and shall comply with the requirements of the latest published edition of NFPA 70, National Electrical Code (NEC®) Article 680 "Swimming Pools, Fountains, and Similar Installations", and any state or local code.

## FILTER PUMP AWARENESS

- **WARNING:** Risk of electric shock. Connect only to a grounding type receptacle. This product is provided with a ground-fault circuit-interrupter. If replacement of the plug or cord is needed, use only identical replacement parts.
- **WARNING:** To reduce the risk of electric shock, replace damaged cord immediately.
- **WARNING:** To reduce the risk of electric shock, do not use the extension cord to connect the unit to the electric supply; provide a properly located outlet.
- **CAUTION:** To reduce the risk of electric shock, the pool must be installed no closer than 6 feet (1.83 m) from any electrical outlet. Do not place portable appliances closer than 5 feet (1.5 m) to the pool.
- **CAUTION:** This pump is for use with storable pools only. Do not use with permanently-installed pools. A storable pool is constructed so that it is capable of being readily disassembled for storage and reassembled to its original integrity. A permanently-installed pool is constructed in or on the ground or in a building such that it cannot be readily disassembled for storage.
- **CAUTION:** For continued protection against possible electric shock, this unit is to be mounted to the base in accordance with the installation instructions.
- Do not bury the cord. Locate cord to minimize abuse from lawn mowers, hedge trimmers, and other equipment.
- If the pump is equipped with a Ground-Fault Circuit-Interrupter (GFCI), follow the steps below to test the GFCI's leakage protection function:  
Plug the GFCI power cord set into the power outlet, make sure the pump is in working mode (i.e. display screen of the GFCI plug IS NOT showing "0"). Press the "TEST" button, the power to the pump should be interrupted by the GFCI and the pump will stop working. Press the "RESET" button to restore the power. If the GFCI fails to interrupt the power to the pump while it is on, the GFCI is defective, so contact Customer Service. If the GFCI interrupts power to the pump without the Test button being pushed, that means a ground current is flowing, indicating the possibility of an electric shock. In this case, stop using the pump immediately, disconnect the pump from the power outlet, and have the problem corrected by a qualified service representative before using the product again.
- The Filter Pump is to be assembled by an adult; care should be taken in the unpacking and assembling of the Filter Pump. This pool may contain accessible potentially hazardous sharp edges or sharp points that are a necessary part of the function of the Filter Pump.

- If a drain or suction outlet cover is missing or broken, do not use the pool. Suction can cause body part entrapment, hair and jewelry entanglement, evisceration, or drowning. Repair or replace the drain or suction outlet cover before allowing the pool to be used. During nighttime pool use, artificial lighting shall be used to illuminate all safety signs, ladders, steps, deck surfaces, and walks.
- The floor of the pool shall be visible at all times from the outside perimeter of the pool.
- Post a list of emergency telephone numbers such as the nearest available police, fire, ambulance, and/or rescue unit. These numbers are to be kept near the telephone that is closest to the pool.
- Basic lifesaving equipment, including one of the following should be on hand at all times:
  - A light, strong, rigid pole (shepherd's crook) not less than twelve feet (12') [366 cm] long.
  - A minimum one-fourth inch ( $\frac{1}{4}$ " [6.35 mm] diameter rope as long as one and one half (1 ½) times the maximum width of the pool or fifty feet (50') [15.24 meters], whichever is less, which has been firmly attached to a Coast Guard-approved ring buoy having an outside diameter of approximately fifteen inches (15") [38.1 cm], or similarly approved flotation device.
- Pool shall be located at a minimum distance of 6 ft (1.83 m) from any receptacle. All 125-volt, 15- and 20-ampere receptacles located within 20 ft (6.0 m) of the pool shall be protected by a ground fault circuit interrupter (GFCI), where distances are by measuring the shortest path from the supply cord of an appliance connected to the receptacle, without piercing a floor, wall, ceiling, doorway with hinged or sliding door, window opening, or other effective permanent barrier, to the inside pool wall.

## CIRCULATION SYSTEMS

- The installer shall follow written instructions regarding positioning of all equipment connected to the circulation systems.
- The installer shall follow written instructions provided for operating the circulation system components.
- All circulation system components and pump that require replacement or servicing shall be installed according to the pump's user guide.
- Circulation equipment shall be installed per manufacturer's instructions to provide proper mounting and support, to prevent damage from misalignment, settlement, and vibration, and to minimize the potential for the accumulation of debris and moisture. Please refer to the pump's user guide.

## CHEMICALS

For safety sake, ensure the deepest part of the pool is always visible. The user must properly maintain the clarity of the pool water at all times. Check the pH and chlorine levels periodically and make sure they are within the recommended limits. Additional water treatment chemicals might be needed from time to time. Have the water sample tested by a local pool supply store to determine if additional chemical is needed. Turn on the pump for the recommended hours daily. If you are unsure of the time frames please refer to [funsicle.com/support](https://funsicle.com/support) for the recommended Pump Operation Hours based on pool types and sizes. Clean and replace filter cartridge frequently. Replace only with a genuine Polygroup® / Funsicle® Brand filter cartridge. Refer to the Filter Pump User Guide for additional water care information.

## RISK OF ENTRAPMENT

- Entrapment Avoidance: There shall be no protrusions or other obstruction in the swimming area, which may cause entrapment or entanglement of the user. If a suction outlet cover is missing or broken, do not use the pool. Suction can cause body part entrapment, hair and jewelry entanglement, evisceration, or drowning. Repair or replace the suction outlet cover before allowing the pool to be used.
- **DANGER! TO AVOID SERIOUS INJURY OR DEATH, CLOSE THE POOL OR SPA TO BATHERS IF ANY SUCTION OUTLET COVER/GRATE IS MISSING, BROKEN, OR INOPERATIVE.**
- Never play or swim near drains or suction fittings. Your body or hair may be trapped causing permanent injury or drowning.

- Never enter the pool or spa if a suction fitting or drain cover is loose, broken, or missing.
- Immediately notify the pool/spa owner or operator if you find a drain cover loose, broken, or missing.

## RISK OF DROWNING

- Keep unsupervised children from accessing the pool by installing fencing or other approved barriers around all sides of pool. State or local laws or codes may require fencing or other approved barriers. Check state or local laws and codes before setting up the pool.
- Toys, chairs, tables, or similar objects that a young child could climb shall be at least four feet (4') [121.92 cm] from the pool. The pump filter system shall be positioned so as to prevent it being used as a means of access to the pool by young children. Do not leave toys inside pool when no longer in use, as toys and similar items might attract a child to the pool.
- Position furniture (for example: tables, chairs) away from pool and so that children cannot climb on it to gain access to the pool.

## RISK OF ELECTROCUTION

- Keep all electrical lines, radios, speakers, and other electrical appliances away from the pool.
- Do not place the pool near or under overhead electrical lines.

## FIRST AID

- Keep a working phone and a list of emergency numbers near the pool.
- Become certified in cardiopulmonary resuscitation (CPR). In the event of an emergency, immediate use of CPR can make a lifesaving difference.

## SPECIAL WARNING

- Local building codes may require obtaining a building or electrical permit. Installer shall follow regulations on setback, barriers, devices, and other conditions.
- Safety signs shall comply with requirements of ANSI-Z535 and use signal wording.
- DO NOT attempt to assemble this pool in adverse weather conditions, windy conditions, or when the temperature is below 60°F.
- This is a storable filter pump, which should be disassembled and stored when temperatures are expected to fall below 32°F.

## EXTRA SAFETY WARNING

- Adult supervision is always required.
- Parents should learn CPR.
- Keep all electrical radios, speakers, and other appliances away from the swimming pool.
- When you touch the filter, pump, or electrical parts, be sure the ground under your feet is "Bone Dry."
- All electrical outlets should have a GFCI, and connections should be a minimum of 6 feet (1.83 m) from the outside perimeter of the wall of the pool. From 6–10 feet (1.83–3.05 m), there should be either a fixed connection (outlet box) or twistlock connection with a GFCI.
- Connect power cords to a 3-wire grounding-type outlet only.
- Keep all breakable objects out of the pool area.
- Alcohol consumption and pool activities do not mix. Never allow anyone to swim, dive, or slide under the influence of alcohol or drugs.
- Severe electrical shock could result if you install your pump or filter on a deck. The pump or filter could fall into the water, causing severe shock or electrocution.

- Do not install on a deck or other surface at, above, or slightly below the top rail of the pool.
- Do not use the filter pump during severe weather conditions, i.e. electrical storms, tornadoes, etc.
- Be aware of overhead power lines when vacuuming your pool or using a telescoping pole.
- Check regularly for signs of wear or loose bolts that could make the deck unsafe.
- Please contact pool site dealer or manufacturer for additional safety signs if deemed necessary.
- For pool service, select a certified pool professional. For additional safety information, see [www.APSP.org](http://www.APSP.org)

## CONSUMER AWARENESS BOOKLETS AND INFORMATION SOURCE

**Contact:** U.S. Consumer Product Safety Commission at [www.cpsc.gov/safety-education/safety-guides/pools-and-spas](http://www.cpsc.gov/safety-education/safety-guides/pools-and-spas), Pub. #362 "Safety Barrier Guidelines for Home Pools."

- The Sensible Way to Enjoy Your Above-ground/On-ground Swimming Pool.
- Children Aren't Waterproof.
- Layers of Protection.
- Pool and Spa Emergency Procedures for Infants and Children.
- Be Safety Aware.

Copies of the above brochures are available free from the APSP at [www.APSP.org](http://www.APSP.org)

## SAFETY EDUCATION PROGRAMS AND MATERIALS

Educational programs and materials (i.e. seminars, workshops, brochures, videos, instructional guides) are available from the APSP, other aquatic safety groups, and by private firms. As a means of communicating useful safety information to pool owners/operators and users, industry members are permitted to provide such information to owners/operators and to request or require owners/operators to sign a statement that they have received, read, and will follow the guidelines.

### Other sources of safety information:

- [cdc.gov](http://cdc.gov)
- [cpsc.gov](http://cpsc.gov)
- [drowningpreventionalliance.com](http://drowningpreventionalliance.com)
- [nspf.org](http://nspf.org)
- [safekids.org](http://safekids.org)

#### **NSF International**

P.O. Box 130140  
789 N. Dixboro Road  
Ann Arbor MI 481105  
Contact: 800-673-6275 or 734-769-8010  
[nsf.org](http://nsf.org)

#### **ANSI American National Standards Institute**

25 West 43rd Street, New York NY 10036  
Contact: 212-642-4900  
[ansi.org](http://ansi.org)

#### **ASTM International (formerly American Society of Testing & Materials)**

100 Barr Harbor Drive, P.O. Box C700 West  
Conshohocken, PA 19428-2959  
Contact: 877-909-2786 (USA & Canada)  
or 610-832-9585 (International)  
[astm.org](http://astm.org)

#### **APSP Association of Pool & Spa Professionals**

(Formerly National Spa and Pool Institute)  
2111 Eisenhower Avenue, Ste. 500  
Alexandria VA 22314-4679  
Contact: 703-838-0083  
[apsp.org](http://apsp.org)

#### **NEC National Electrical Code (see NFPA)**

NFPA National Fire Protection Association  
1 Batterymarch Park, Quincy MA 02169-7471  
Contact: 800-344-3555 (U.S. & Canada) or  
617-770-3000 (International)  
[nfpa.org](http://nfpa.org)

#### **NSPI National Spa and Pool Institute (see APSP)**

UL Underwriters Laboratories  
333 Pfingsten Road, Northbrook IL 60062-2096  
Contact: 877-854-3577 or 847-272-8800  
[ul.com](http://ul.com)

#### **ASME American Society of Mechanical Engineers**

Two Park Avenue, New York NY 10016-5990  
Contact: 800-843-2763 (USA & Canada) or  
973-882-1170 (Outside N. America)  
[asme.org](http://asme.org)



## FILTRATION SYSTEMS

Any equipment connected to the circulation systems shall be positioned so as to prevent their being used as a means of access to the pool by young children. (See the latest published edition of ANSI/APSP-8 Model Barrier Code for Residential Swimming Pools, Spas, and Hot Tubs.)

## BARRIER

A barrier is necessary to provide protection against potential drowning and near drowning, and barriers are not a substitute for the constant supervision of children. (See latest published edition of ANSI/APSP-8 Model Barrier Code for Residential Swimming Pools, Spas, and Hot Tubs.)

## RISK OF DROWNING, ENTRAPMENT, AND DIVING ACCIDENTS

Publications are available that describe the risk of drowning, entrapment, and diving accidents. Available publications related to pool safety include the Association of Pool and Spa Professionals' (APSP) booklets entitled: The Sensible Way to Enjoy Your Above-ground/On-ground Swimming Pool, Children Aren't Waterproof, Pool and Spa Emergency Procedures for Infants and Children, Layers of Protection, and the latest published edition of ANSI/APSP-8 Model Barrier Code for Residential Swimming Pools, Spas, and Hot Tubs.

## INSTALLER RESPONSIBILITIES

All of these components shall be positioned so as to prevent their being used as a means of access to the pool by young children. (See Barrier Code for Residential Swimming Pools, Spas, and Hot Tubs.)

## FCC NOTICES

This device complies with Part 15 of the FCC Rules. Operation is subject to the following two conditions:

1. This device may not cause harmful interference.
2. This device must accept any interference received, including interference that may cause undesired operation.

**WARNING!** Changes or modifications to this unit not expressly approved by the party responsible for compliance could void the user's authority to operate the equipment.

**NOTE:** This equipment has been tested and found to comply with the limits for a Class B digital device, pursuant to Part 15 of the FCC Rules. These limits are designed to provide reasonable protection against harmful interference in a residential installation. This equipment generates, uses, and can radiate radio frequency energy and, if not installed and used in accordance with the instructions, may cause harmful interference to radio communications. However, there is no guarantee that interference will not occur in a particular installation. If this equipment does cause harmful interference to radio or television reception, which can be determined by turning the equipment off and on, the user is encouraged to try to correct the interference by one or more of the following measures:

- Reorient or relocate the receiving antenna.
- Increase the separation between the equipment and receiver.
- Connect the equipment into an outlet on a circuit different from that to which the receiver is connected.
- Consult the dealer or an experienced radio/TV technician for help.

POLYGROUP SERVICES N.A. INC.  
303 SW 16th Street, Suite 5, Bentonville, AR, 72712, USA

# SAVE THESE INSTRUCTIONS

# Before You Begin

Before assembling your filter pump, check the contents and become familiar with all the parts. Review all the following warnings, guidelines and tips before proceeding with setup:

## Preliminary Steps

- READ ALL INSTRUCTIONS CAREFULLY and get a thorough understanding of what is required to assemble your ST Series Filter Pump.
- Before you begin to assemble the pool, identify, count, and check all parts needed for assembly.
- It is recommended that you have some PETROLEUM JELLY on hand for lubricating the gaskets.
- Installer shall follow written instructions provided for operation of the filter pump systems.
- All electrical components shall be installed in accordance with Article 680 of the National Electrical Code (NEC) "Swimming Pools, Fountains and Similar Installations" or its latest approved edition.
- The ST Series Sand Filtration Systems are manufactured by Polygroup® and ETL control number 4000608 and 4006317 - double insulated and grounded - 120VAC 60Hz. All units must have a minimum of 105VAC to start and run properly.

## Filter Pump Power Specifications

Sand Pump Model	Voltage & Frequency	Amperage
10" SAND FILTER (WITH CP2000 PUMP)	120V~ 60Hz	3.0 Amps
12" SAND FILTER (WITH CP2000 PUMP)	120V~ 60Hz	3.0 Amps

## Parts List

ITEMS	PARTS NAME		QTY.	ITEMS	PARTS NAME		QTY.
①	Sand Tank Base	A) ST1100	1	①	Drain Indicator		1
		B) ST1600					
②	Sand Tank	A) ST1100	1	②	6-Port Valve Handle		1
		B) ST1600					
③	Drain Valve Cap		1	③	Gasket (Outer Diameter: 90 mm)		3
④	GFCI Power Cord Set		1				
⑤	Center Pipe	A) ST1100	1	④	Suction Fitting (SF)		2
		B) ST1600					
⑥	Sand Guard		1	⑤	Thrust Washer		3
⑦	Clamp		1				
⑧	Camshaft Bolt Cap		1	⑥	Split Suction Fitting Lock Nut (for pump included with the pool)		1
⑨	Gasket (Outer Diameter: 152 mm)		1				
⑩	6-Port Valve		1	⑦	Solo Suction Fitting Lock Nut (for pump included with the pool)		1
⑪	Blue Drain Outlet Cap		1				
⑫	Pressure Gauge		1	⑧	Solo Suction Fitting Lock Nut (for pump sold separately)		2
⑬	13A:	36" Hose (for pump included with the pool)	1		⑨	SF Cap	
		36" Hose (for pump sold separately)	2	RF 90° Elbow			
	13B:	59" Hose (for pump included with the pool)	2	RF Nut			
		59" Hose (for pump sold separately)	2	Y-Shaped Hose Connector (for pump sold separately)			
⑭	Short Hose	A) ST1100 12" Hose	1	Lock Nut Seal Ring		2	
		B) ST1600 16" Hose		Return Fitting (RF)		1	
⑮	Hose Clamp (for pump included with the pool)		8	Snap On RF Diverter		1	
	Hose Clamp (for pump sold separately)		10	RF Locking Ring		1	
⑯	Lock Pin		2	RF Service Plug		1	
⑰	Pump		1	Wrench		1	
⑱	1.5" Fitting O-Ring (for pump included with the pool)		10	Drain Valve Filter		1	
	1.5" Fitting O-Ring (for pump sold separately)		12	Drain Valve Filter O-Ring		1	
				Vent Cap		1	

## Sand Specifications:

Fill the tank with #20 silica sand ONLY. You can purchase the sand from your local home improvement or building material stores.

**WARNING: Using the incorrect sand may damage the filtration system and will void the warranty.**

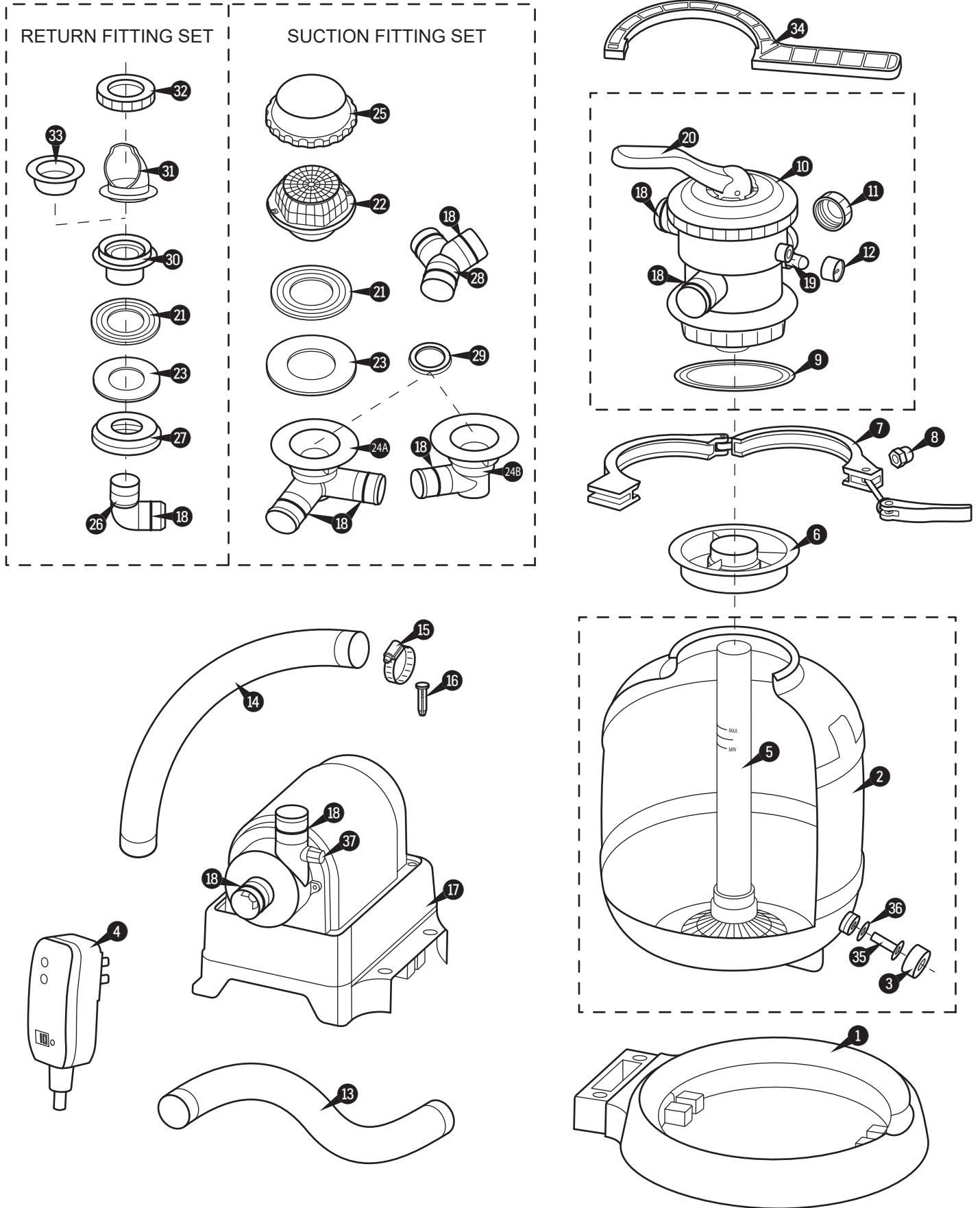

# Setting Up the Sand Filter Pump

**WARNING: Climbing hazard! Please prevent children from climbing on the filtration system to gain access to the pool.**

## STEP 1: Install the Suction & Return Fittings

1. Set up the pool by following all the instructions that came with the pool. DO NOT fill with water until the Filter Pump is properly installed. Locate the Outlet and Inlet openings on the pool wall.

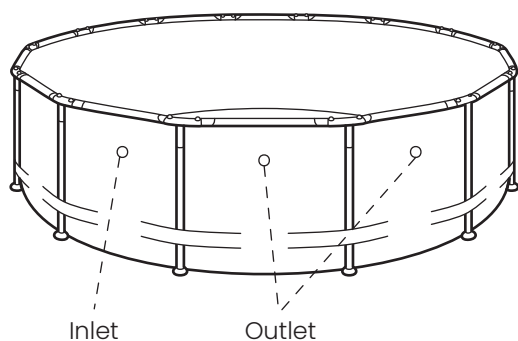

2. Install the Suction Fitting components into the Outlet opening.

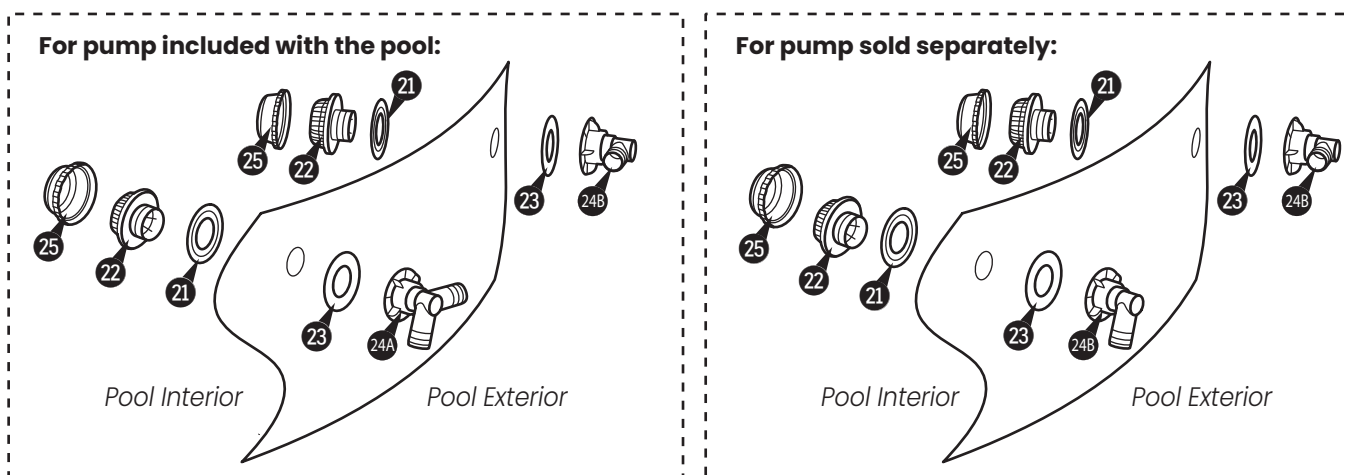

3. Install the Return Fitting 30 on the Inlet opening of the pool.

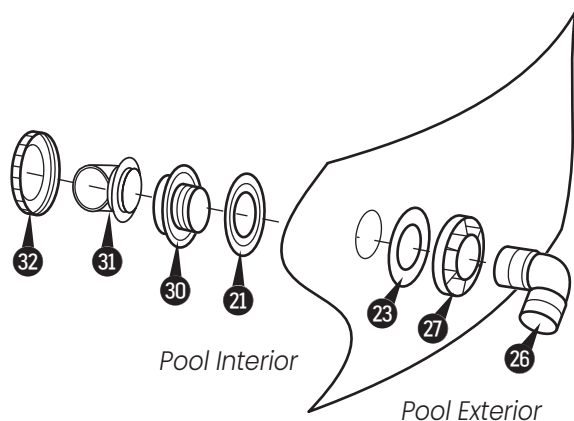

## STEP 2: Install the Sand Filter Pump

1. Snap the Pump **17** on to the Sand Tank Base **1**.

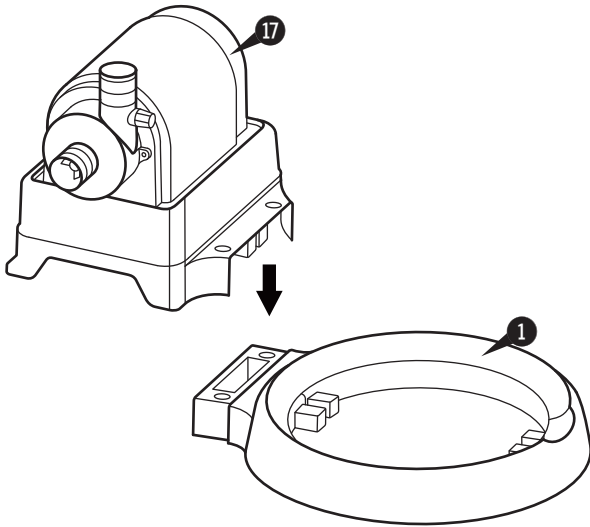

2. Insert and push the Lock Pins **16** all the way down to secure the Pump **17** to the Sand Tank Base **1**.

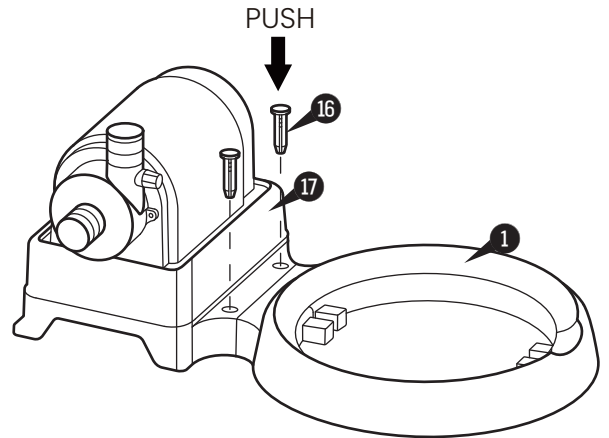

3. With the Drain Valve of the Sand Tank **2** pointing outwards, place the Sand Tank **2** onto the Sand Tank Base **1**.

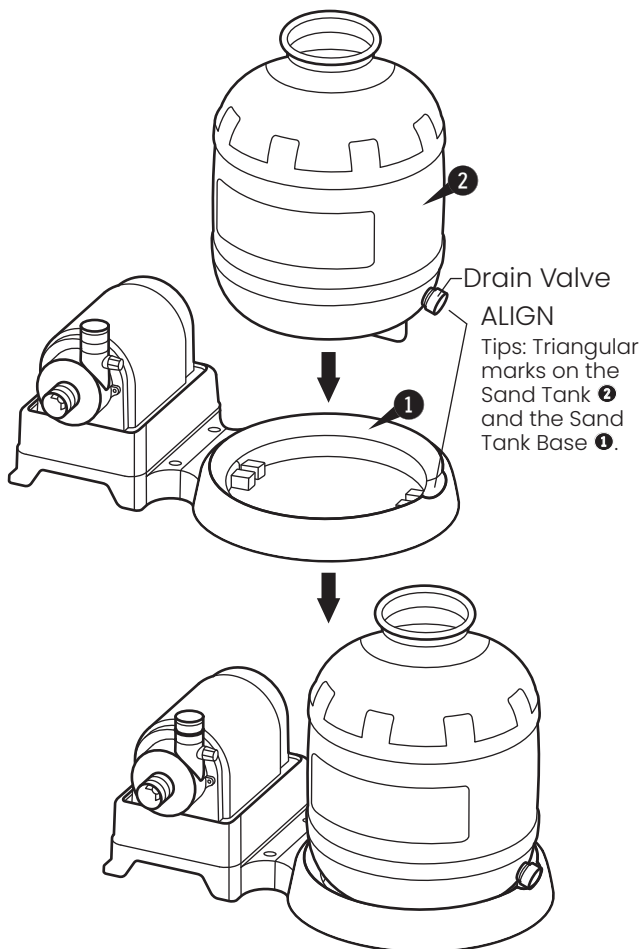

4. Put the Center Pipe **5** into the Sand Tank **2**. Position the Center Pipe **5** at the bottom center of the Sand Tank **2**.

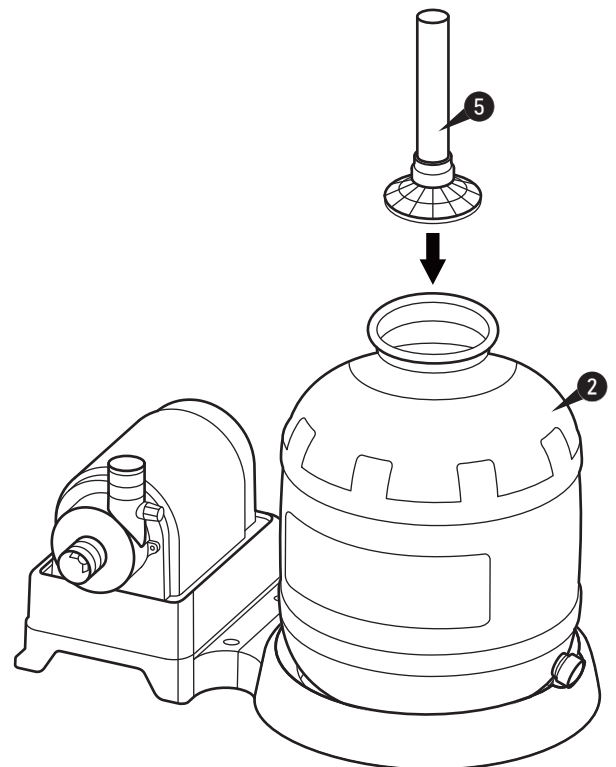

5. Place the Sand Guard **6** over the top opening of the Center Pipe **5**.

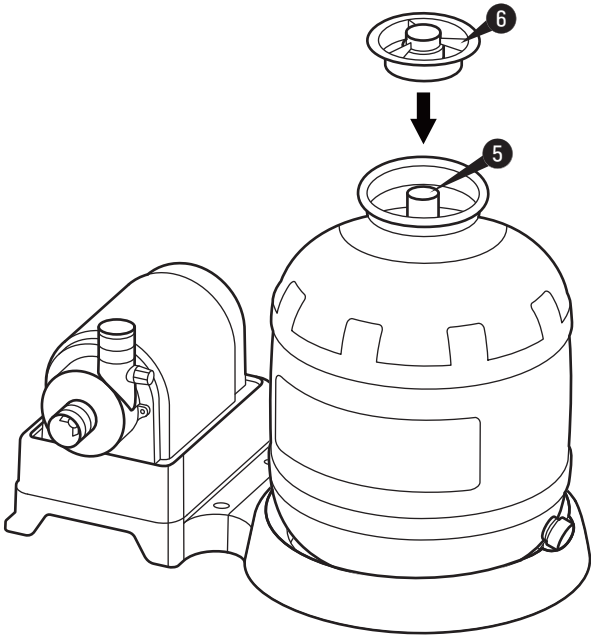

6. **Fill the tank with #20 silica sand ONLY.** You can purchase the sand from your local home improvement or building material stores. Slowly pour sand into the Sand Tank **2** until the sand level is between the Min and Max marks on the Center Pipe **5**.

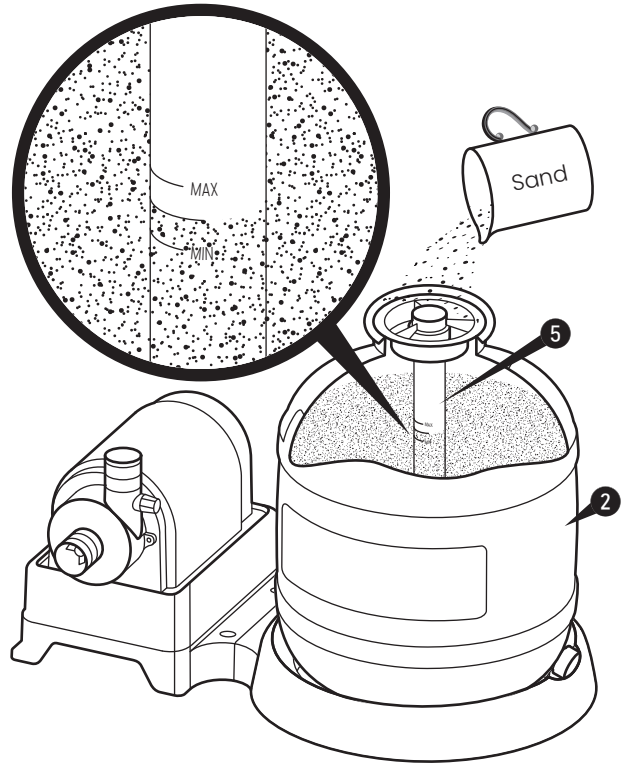

7. Remove the Sand Guard **6** and save for future use.

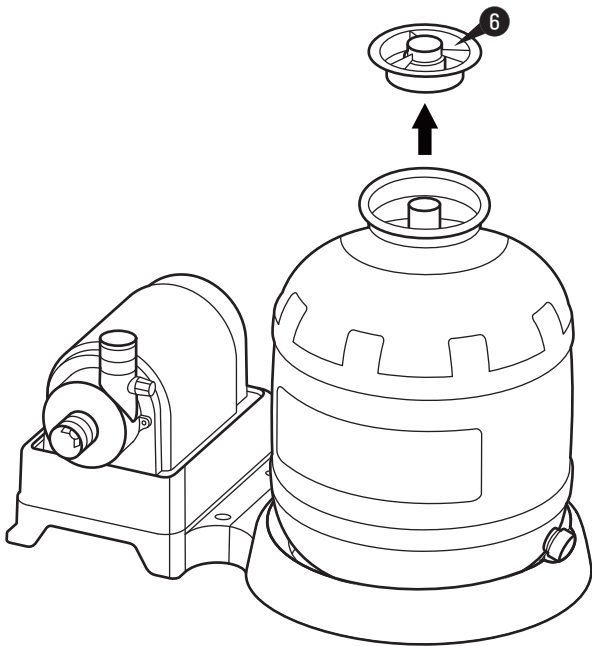

8. Install the 6-Port Valve **10** to the Sand Tank **2**, and ensure it fits securely into the Center Pipe **5**. Rotate the Valve so that the triangular mark under the Pressure Gauge **12** is aligned with the triangular mark on the Sand Tank **2**.

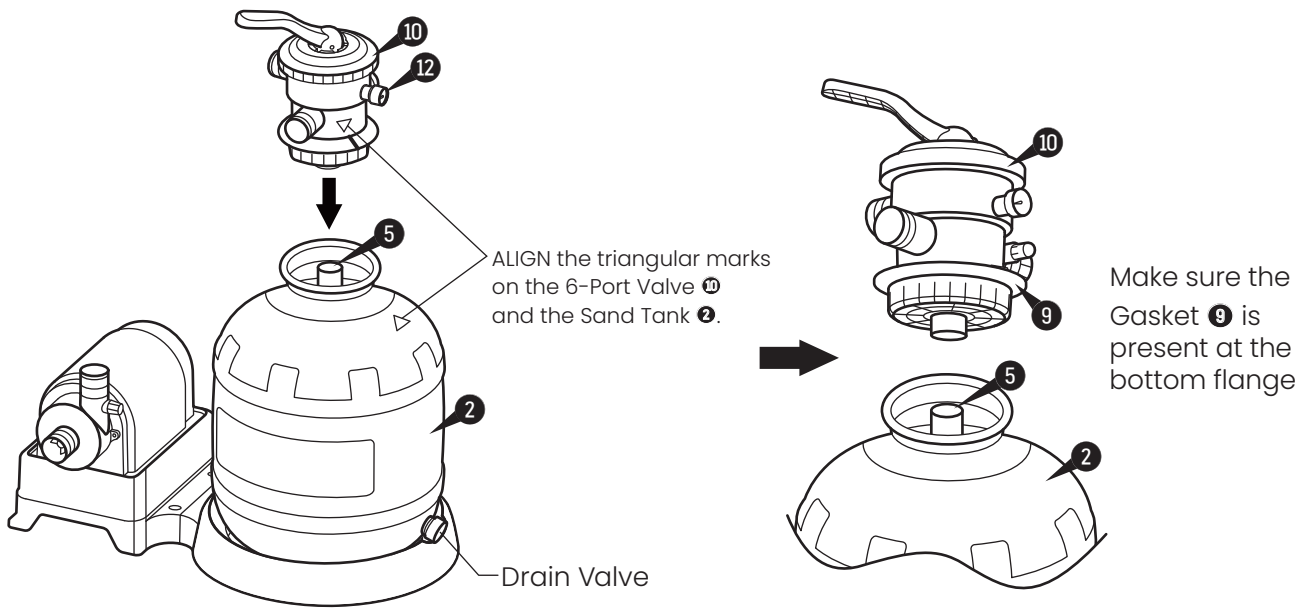

9. Place the Clamp **7** around the flange of the 6-Port Valve **10** and Sand Tank **2**. **IMPORTANT:** Align the hinge on the Clamp **7** with the ridge on the flange of the 6-Port Valve **10**.

10. Close the Clamp **7** by pushing the two jaws as close together as possible.

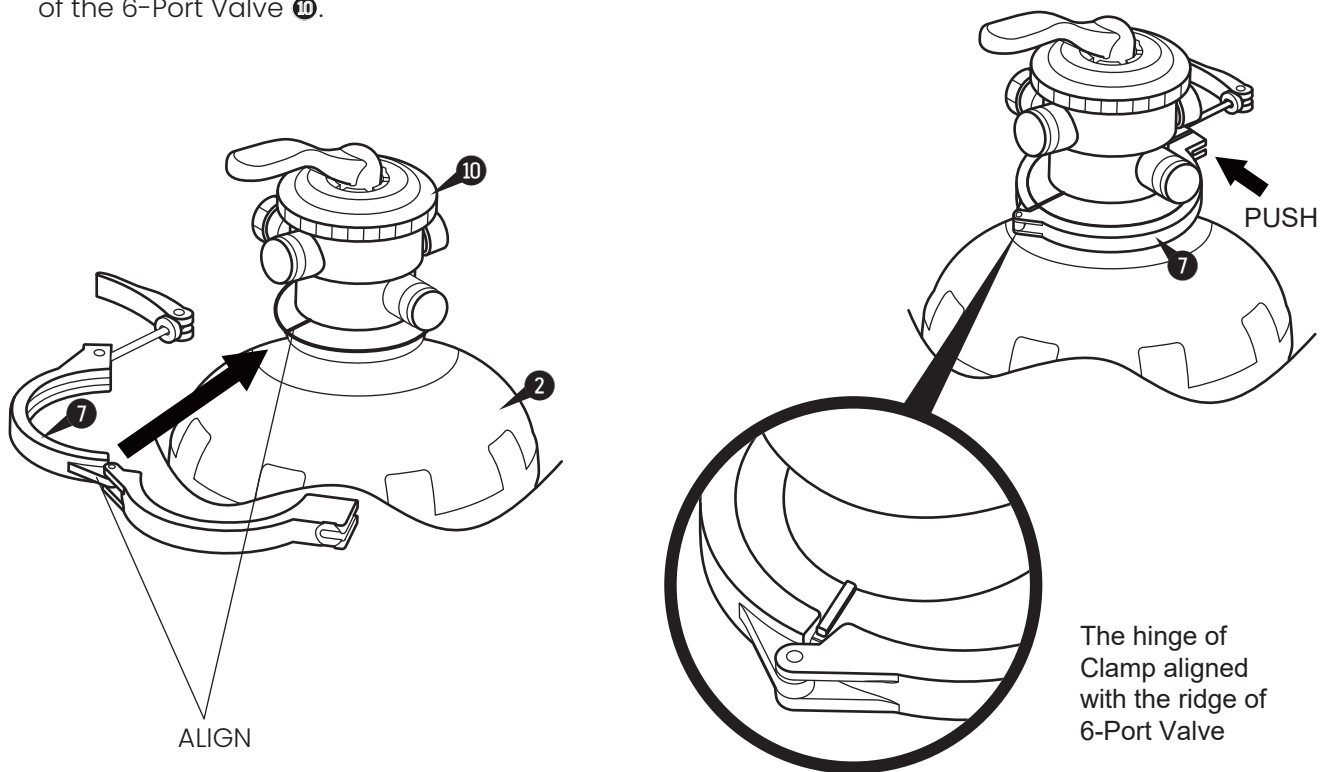



11. Pull on the Cam Handle, and insert the Cam Bolt into the opposite jaw until it locks in place.

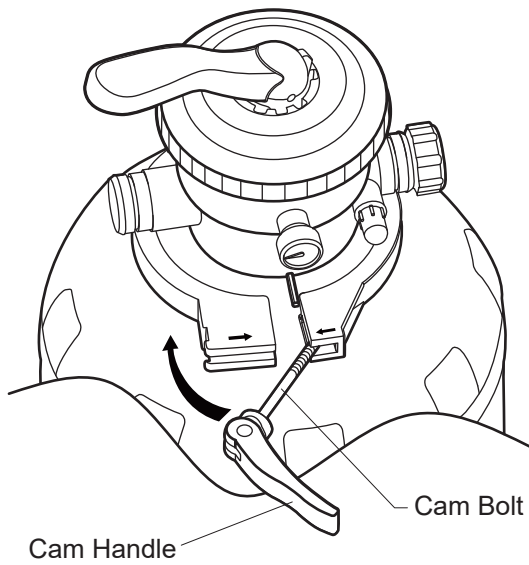

12. Hold the Cam Handle with one hand and start turning in clockwise direction to close the jaws further.

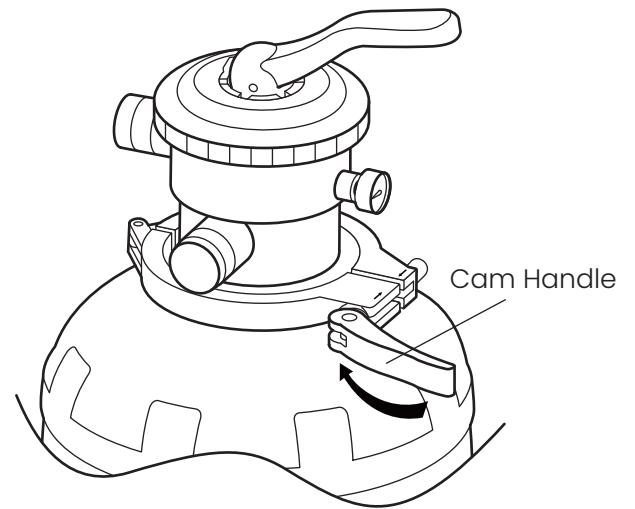

13. When the Clamp 7 is tightened and no more turns can be made, flip and push the Cam Handle towards the Sand Tank 2 to secure.

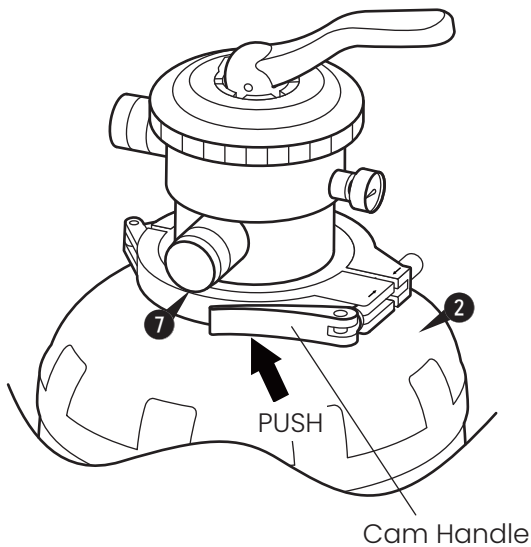

14. Connect the Short Hose 14 between the Pump Outlet and the 6-Port Valve Inlet. Tighten the Hose Clamps 15 with a cross-head screwdriver (not included). The sand filter pump is now fully assembled.

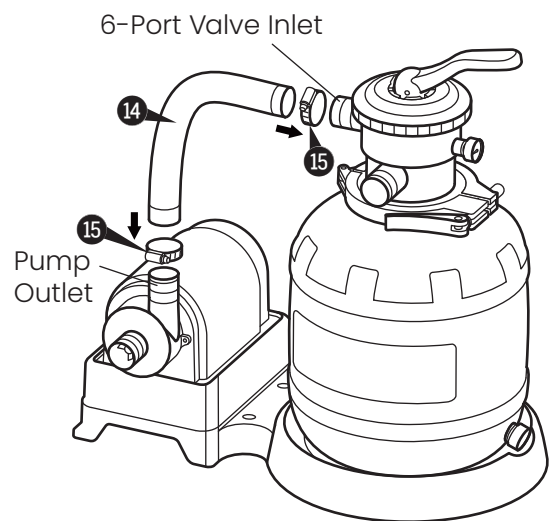

15. Connect the Pump Inlet to the Pool Outlet as follows:

**For pump included with the pool:**

Turn the Split Suction Fitting Lock Nut **24A** with one end facing downwards, then connect this end to the Pump inlet with a Hose and one Clamp on each end. Connect the other end of the Split Suction Fitting Lock Nut **24A** to the Solo Suction Fitting Lock Nut **24B** with another hose.

**For pump sold separately:**

Connect each of the Solo Suction Fitting Lock Nut **24B** with one Hose and one Clamp respectively. Then, connect the other end of the two hoses with the Y-Shaped Hose Connector **28**. Connect the open end of the Y-Shaped Hose Connector **28** to the Pump inlet with one Hose and one Clamp.

16. Connect the 6-Port Valve Outlet to the RF 90° Elbow **26** of the Return Fitting Set with another Hose and one Clamp on each end.

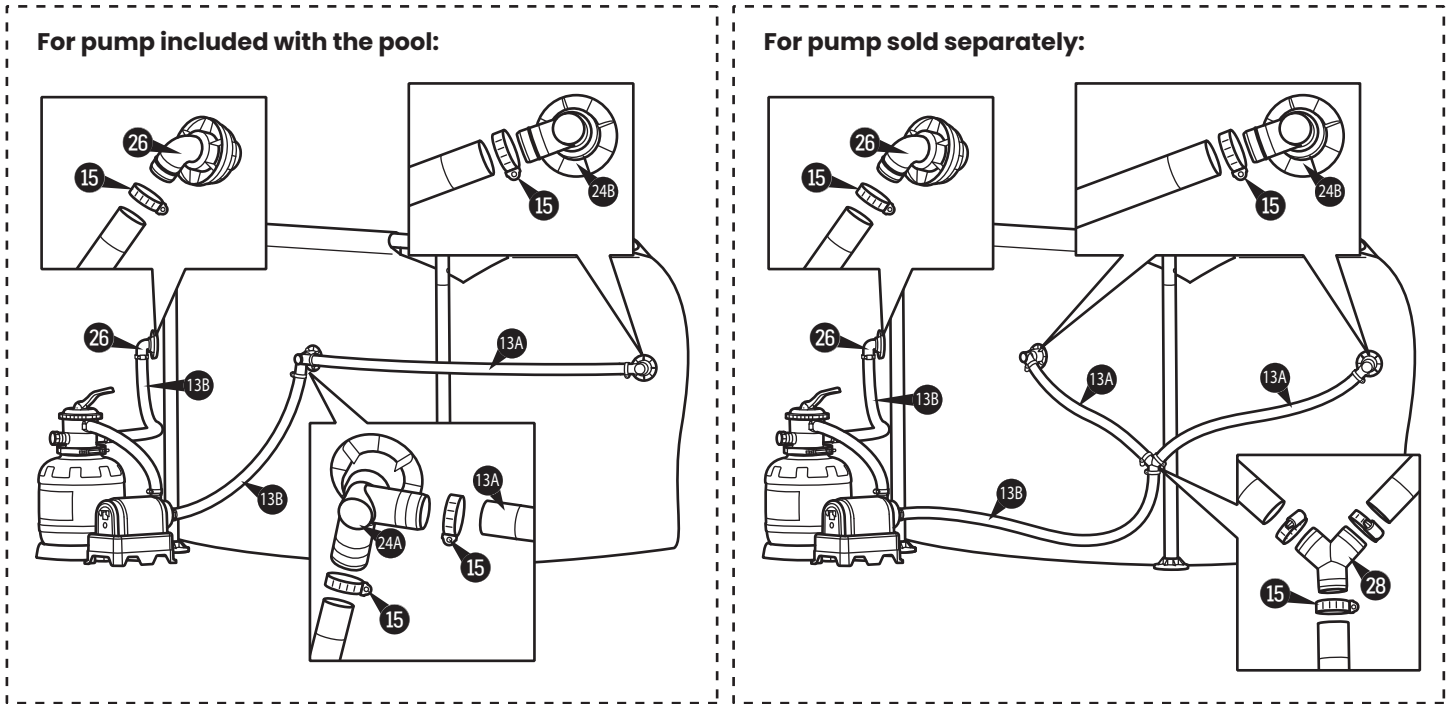

17. Make sure the Hose Clamps **15** seal tightly over both the Hose **13** and O-Rings **18**. Tighten all the Clamps with a cross-head screwdriver (not included).

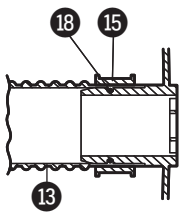

# Using the Pump

## Before using the Pump

### IMPORTANT:

1. Make sure to press the pump power switch to OFF before plugging the Power Cord Set ❶ into a power outlet.
2. Always PRESS DOWN the 6-Port Valve Handle ❷ BEFORE switching handle positions.
3. Always BACKWASH the sand before filtering. This prevents fine sand from going through the pump and then into the pool, meanwhile washes off the dirt and debris of the sand.
4. Make sure that the Hoses ❸ ❹ are firmly secured to the fittings on the pump and the pool.
5. Fill the pool with water up to the FILL LINE. Do NOT dry run the filter pump.
6. FILTER PUMP ALONE WILL NOT PREVENT ALGAE FROM GROWING IN POOL WATER; THIS CAN ONLY BE DONE BY MAINTAINING PROPER CHLORINE AND pH LEVELS AT ALL TIMES. For details, see **Caring for Your Pool (p. 22)**.

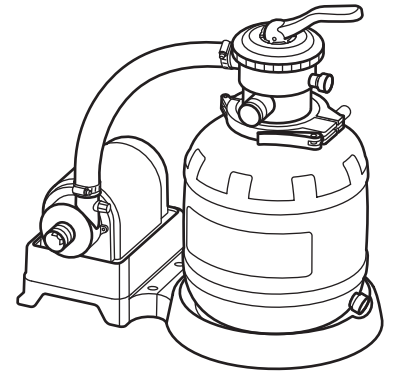

## FUNCTIONS OF 6-PORT VALVE

Valve Handle Position	Function	Water Flow Direction
1 BACKWASH	Reverses the water flow to wash the sand Also prevents fine sand from ending up in your pool <b>ALWAYS remove the Blue Drain Outlet Cap ❶ before using this setting, and replace the cap when done.</b> * Backwash the sand when the pressure reading is 1-1.5 bar (14.5-21.8 psi) ABOVE the initial pressure OR at least once every 2 weeks. <b>Note:</b> It is normal for a small amount of fine sand to drain out from the drain outlet during the backwash process. <b>Continue to backwash until the water from the drain outlet runs clean.</b>	Pool → Pump → Sand (Backward) → Drain Outlet
2 RINSE	Levels out the sand bed after backwashing <b>ALWAYS remove the Blue Drain Outlet Cap ❶ before using this setting, and replace the cap when done.</b> <b>Continue to rinse until the water from the drain outlet runs clean.</b>	Pool → Pump → Sand (Forward) → Drain Outlet
3 FILTER	Normal filtration and vacuuming of the pool	Pool → Pump → Sand (Forward) → Pool
WASTE	Vacuums water directly to drain and lowers the pool water level <b>ALWAYS remove the Blue Drain Outlet Cap ❶ before using this setting, and replace the cap when done.</b>	Pool → Pump → Drain Outlet
RECIRCULATE	Recirculates water without filtering	Pool → Pump → Pool
CLOSED <b>DO NOT SWITCH ON THE PUMP</b>	Shuts off the water flow between the sand filter system and the pool <b>DO NOT SWITCH ON THE PUMP</b>	No water flow <b>DO NOT SWITCH ON THE PUMP</b>
NULL	For winterizing and storage	Excess water flow

## Use the Pump

1. Make sure the pump is switched OFF.
2. Plug the Power Cord Set ④ to a grounded receptacle.

3. **BACKWASH the sand:**

**ALWAYS BACKWASH THE SAND BEFORE FILTERING.**

**This prevents fine sand from going through the pump and then to the pool, meanwhile washes off the dirt and debris of the sand.**

- a. Remove the Blue Drain Outlet Cap ⑪. (Optionally, connect a 1.5" [38mm] hose to the drain outlet to direct the waste water to a nearby drain)

- b. Press down the 6-Port Valve Handle ⑳ and turn it to BACKWASH.

- c. Switch the pump on.

Refer to "**GFCI Plug Instructions (p. 21)**" for the operating instructions with **GFCI** plug.

The water should now be circulating backward through the sand bed to the drain outlet. Continue to BACKWASH until the drain water runs clear, or the Drain Indicator ⑲ shows clear water.

**Note:** It is normal for a small amount of fine sand to drain out from the drain outlet during the backwash process.

- d. Switch the pump off.

4. **RINSE the sand:**

**The RINSE function will clean up and level out the sand bed after each BACKWASHING.**

- a. Press down the 6-Port Valve Handle ⑳ and turn it to RINSE.

- b. Switch the pump on. RINSE for ONE MINUTE, then switch the pump off.

- c. Put back and retighten the Blue Drain Outlet Cap ⑪.

5. **FILTER the pool:**

- a. Press the 6-Port Valve Handle ⑳ down and turn it to FILTER.

- b. Switch the pump on.

- c. Jot down the sand tank pressure reading of Pressure Gauge ⑫. This reading indicates the

**"initial pressure"**, meaning the tank pressure when the sand bed is clean. Backwash the sand bed whenever the reading is 1-1.5 bar (14.5-21.8 psi) above the initial pressure, or once every TWO weeks to maintain water cleanliness.

6. To turn off the pump, press the power switch to OFF and unplug Power Cord Set ④.

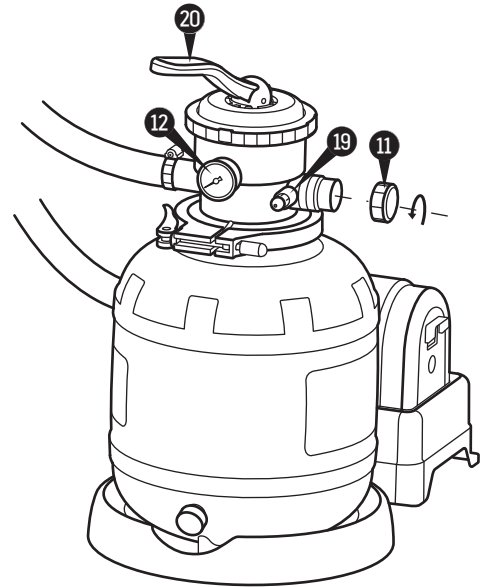

## GFCI Plug Instructions

1. Locate a grounded receptacle at least 15 feet (4.5 m) away from the pool.
2. To turn on the Pump, plug in the **GFCI power cord set ④** to the power outlet.
3. The **GFCI power cord set ④** comes with a pre-set timer function.
  - a. **Default timer setting:** When the power is on, the display screen shows "10", indicating that the default operating time of the pump is 10 hours. The pump will automatically turn off after the 10 hours and will remain off for 14 hours. This is based on a 24-hour cycle. This cycle will then continue as long as the power is on.
  - b. **Time adjustment:** Press the "SET" button to set the desired operating time of the pump between 1 to 10 hours, with each press adjusts the time by 1 hour. For example, when the display screen on the plug shows "05", the pump will work for 5 hours and restart after a 19 hours break.
  - c. If the display screen shows "0", it indicates that the pre-set working time has ended and the pump is currently off.
  - d. To restart the pump earlier than the pre-set time, press the "SET" button. In this case, the pre-set working time will adjust by 1 hour from the previous setting.
4. To turn off the pump, press the "TEST" button of the GFCI Plug, and unplug it from the power outlet. If you accidentally press the "TEST" button while the pump is working, you can press the "RESET" button to restore the pump to work.

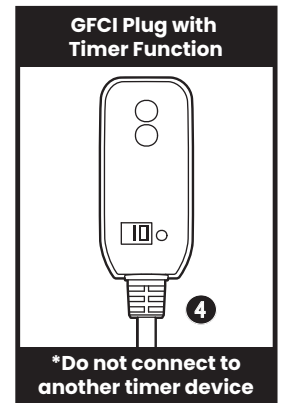

### Description of GFCI Plug with Timer Function

<p style="text-align: center;">○ RESET ○ TEST</p> <p style="text-align: center;">□ SET</p>	<p>"RESET" button:</p> <ul style="list-style-type: none"> <li>• When the display screen shows a number between "01" to "10", but the pump is not operating (e.g. the "TEST" button is pressed while the pump is working), press the "RESET" button to restore the pump to work.</li> <li>• When the display screen shows "0" and the pump has stopped working, pressing the "RESET" button will have no action.</li> </ul>
	<p>"TEST" button:</p> <ul style="list-style-type: none"> <li>• To test the GFCI's leakage protection function: Plug the GFCI power cord set into the power outlet, make sure the pump is in working mode (i.e. display screen of the GFCI plug IS NOT showing "0"). Push the "TEST" button, the power to the pump should be interrupted by the GFCI and the pump will stop working.</li> <li>• When the display screen shows "0" and the pump has stopped working, pressing the "TEST" button will have no action.</li> </ul>
	<p>"SET" button:</p> <ul style="list-style-type: none"> <li>• Press the "SET" button to select the desired operating time of the pump between 1 to 10 hours, with each press adjusts the time by 1 hour.</li> <li>• If the display screen shows "0", press the "SET" button will restart the pump. In this case, the pre-set operating time will be adjusted by 1 hour from the previous setting.</li> </ul> <p><b>NOTE:</b> If you find the time interval available for selection is less than 10 hours, it could be the memory setting from the previous cycle. Disconnect the power supply of the GFCI plug and reconnect again, and it will revert back to the default 10 hours range.</p>
	<p>Display Screen:</p> <ul style="list-style-type: none"> <li>• Shows "01", "02"...to "10" to represent the pre-set working time when the GFCI power cord set is plugged into a power outlet.</li> <li>• Shows "0" when the pump is in off mode.</li> </ul>

5. From inside the pool, check if the water flow from the Return Fitting ⑩ is correct. It should feel like a solid stream of water returning to the pool. If not, or if you feel a reduction in flow, refer to Problem 3 of the **Troubleshooting Guide (p. 24)** for possible solutions.
6. **IMPORTANT:** Check and adjust the pH and chlorine levels daily. FILTER PUMP ALONE WILL NOT PREVENT ALGAE FROM GROWING IN POOL WATER; THIS CAN ONLY BE DONE BY MAINTAINING PROPER CHLORINE AND pH LEVELS AT ALL TIMES. For details, see **Caring for Your Pool (p. 22)**.

## Pump Motor Care

**IMPORTANT!** This Sand Filter Pump is protected by a thermal switch, a safety device that stops the pump from running when it is overheated, to prevent damage to the pump and prolong its service life. If your pump turns off automatically, it's likely the pool water temperature is too high or the water flow through the pump is insufficient for cooling down the pump. Check and correct the water flow, and let the motor cool down for at least 15 minutes. The pump will restart automatically after the motor is completely cooled down. If the display screen of the GFCI plug shows "0", press the "SET" button to restart the pump. You could also operate the pump at night when the temperature is lower. If the pump turns off automatically again, inspect if the rotor is blocked by dirt.

# Maintaining the Pump

- BACKWASH the sand bed when the pressure reading is 1-1.5 bar (14.5 - 21.8 psi) above the initial pressure; or, BACKWASH the sand bed at least once every TWO weeks.
- Discard all the sand at the end of the season, and wash the pump components, sand tank and 6-port valve thoroughly with fresh water before storage. Fill up with new sand at the beginning of the swimming season.
- Check the pump output daily. If flow is reduced, see Symptom 3 of **Troubleshooting Guide (p. 24)**.
- Check the pump, hoses and fittings for leaks. If a leak is found, see Symptom 5 & 6 of **Troubleshooting Guide (p. 24)**.

## Caring for Your Pool

- The following items are required to get your pool ready for use. They are available at **funsicle.com** or your local pool supplies stores:
  - a. **Test kit** – for checking the chlorine and pH levels of the pool water
  - b. **Floating chlorine dispenser (not included) and chlorine tablet** – for water disinfection and prevention of the growth of algae
  - c. **pH control chemicals** – for adjusting the pH level up (soda ash) or down (acid)
  - d. **Algaecides** – to eliminate algae
  - e. **Superchlorinator** – to destroy ("shock") the combined chlorine, ammonia, nitrogen, and organic compounds that build up in pool water over time and with extended use
  - f. **Leaf net with handle** – for removing leaves, trash, insects, etc. from the pool

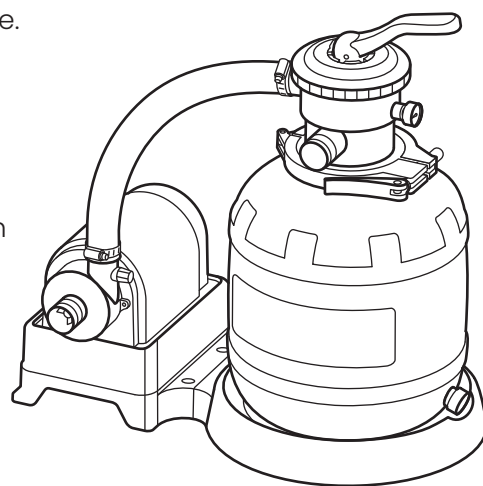

- **IMPORTANT:** it is a MUST to maintain the chlorine and pH levels at all times:
    - a. Check and adjust the pH and chlorine levels daily. FILTER PUMP ALONE WILL NOT PREVENT ALGAE FROM GROWING IN POOL WATER; THIS CAN ONLY BE DONE BY MAINTAINING PROPER CHLORINE AND pH LEVELS AT ALL TIMES.
    - b. Recommended pH level: between 7.3 and 7.8
    - c. Recommended chlorine level: between 1.0 ppm and 1.6 ppm
    - d. Superchlorinate your pool at least every other week.
    - e. Hot weather and heavy use may require the pH and chlorine levels to be maintained on the upper side of the scale as well as a weekly superchlorination.
    - f. Using a pool and/or solar cover will help maintain the pH and chlorine levels by reducing evaporation of pool water.
    - g. **CAUTION:** High chlorine concentration and low pH level will damage the pool/pool liner. You must follow the instructions on quantity and safe usage of the pool chemicals you use. NEVER drop lumps or pellets of chemicals into the pool – this may present a hazard to the swimmers and/or damage your pool liner.
  - Clean your pool regularly using a maintenance kit with vacuum. You can get the kit from [funsicle.com](http://funsicle.com).
  - Using a foot bath prior to entering the pool will help keep the pool clean.
  - Avoid using well water. If you must use well water, always seek professional advice from your local pool chemical suppliers before chemicals into it.
  - Find out the water capacity (in gallon) of your pool. You will need it to determine the amount of chemicals required, or when you contact a pool supplies expert for water testing and advice on safe use of chemicals.
- NOTE:** Always follow the manufacturer label directions of the chemicals you choose to use.

## Winterizing, Disassembly & Storage

---

1. First, unplug the Power Cord Set ④ of the system.
2. Loosen all Hose Clamps ⑮. Remove the Hose ⑬ ⑭ and allow water to drain.
3. Remove Drain Valve Cap ③ from the Sand Tank ② and allow water to drain. Replace and tighten the Drain Valve Cap ③.
4. Clear and lubricate all Fitting O-Rings ⑬ with petroleum jelly.
5. Turn the 6-Port Valve Handle ⑳ to "NULL" position.
6. Allow the sand filter pump to dry completely. Store the sand filter pump in a cool and dry location away from direct sun light.
7. All items should be stored in a dry environment that remains above 32 degrees Fahrenheit at all times.

# Troubleshooting Guide

**WARNING:** Turn off the pump and unplug the power cord before troubleshooting the filter pump.

Problem	Cause	Solution
1. The Pump motor fails to start	A. The Pump not plugged in OR the Power Cord Set 4 not activated	A. Plug the GFCI Power Cord Set to a 3-wire grounded power outlet, then press the RESET button to start the Pump.
	B. Low voltage	B. Check and make sure the line voltage is between 105VAC and 125VAC.
	C. The Power Cord Set 4 and/or circuit breaker tripped	C. If problem persists, have the circuit checked by a qualified electrician.
	D. The Pump motor is too hot, and the thermal safety switch shut it off	D. Let the motor cool down and restart the Pump.
2. The Sand Filter doesn't clean the pool	A. Inadequate chlorine or pH level	A. Adjust the chlorine and pH levels. Consult your local pool supplies stores.
	B. No sand in the Sand Tank 2	B. Fill sand in as per <b>STEP 2: Install the Sand Filter Pump (5)-(7) on p. 15.</b>
	C. Wrong 6-Port Valve 10 setting	C. Set the Valve Handle 20 to "FILTER" position.
	D. The pool is too dirty	D. Run the Pump longer.
	E. Clogged Suction Fitting 22	E. Clean the strainer of the Suction Fitting.
3. The Sand Filter doesn't pump water, or the flow is very slow	A. Clogged Suction Fitting 22 or inlet of the Pump	A. Clean the Suction Fitting and the Hose 13 connecting it to the Pump inlet.
	B. An air leak on the intake Hose 13	B. Check the Hose for damage; tighten the Hose Clamps 15, and check the pool water level.
	C. The sand is too dirty	C. Backwash the sand more frequently.
	D. Crusting or caking of sand surface	D. Replace about 1" (25mm) of the sand, or all the sand if problem persists.
	E. A pool vacuuming device is attached to the Pump	E. Remove the device.
4. The Pump doesn't work	A. Low water level	A. Fill water up to the FILL LINE marked on the pool wall.
	B. Clogged Suction Fitting 22 strainer	B. Clean the strainer.
	C. An air leak on the intake Hose 13	C. Check the Hose for damage; tighten the Hose Clamps 15, and check the pool water level.
	D. Faulty motor or the impeller is jammed	D. Contact our Customer Service.



Problem	Cause	Solution
5. The 6-Port Valve 10 or its locking ring is leaking	A. The Gasket 9 is missing	A. Remove the 6-Port Valve 10 and check to ensure the Gasket is in place.
	B. The Gasket 9 is dirty	B. Clean the Gasket with garden hose water.
	C. Loose Hose Clamps 15	C. Tighten/reinstall the Clamps.
	D. Faulty 6-Port Valve	D. Contact our Customer Service.
6. Leakage at Hoses 13 14	A1. The connection between the Suction Fitting 22 & the Suction Fitting Lock Nut 24A / 24B	A1. Check the connection between Suction Fitting 22 and the Suction Fitting Lock Nut 24A / 24B. If a loose or unbalanced connection is found, re-tighten the Suction Fitting 22 with the Suction Fitting Lock Nut 24A / 24B, make sure they are screwed tightly. <b>Note:</b> Water may still drip out from the connection after the lock nut is re-tightened. There could be water trapped within the connection of the lock nut from before. Simply let the residue water drip out. This may take a few hours for the connection to be completely dry.
	A2. The connection between the Suction 22 / Return Fittings 30 and the Hose 13	A2. Check that the Hose Clamps 15 are properly secured over both the Hoses 13 and their O-rings 18; adjust and re-tighten if necessary. Also, check the Hoses for cracks or holes and replace as needed.
	B. The O-Rings 18 of Hose connections are missing	B. Ensure that the O-Rings are in place and intact.
7. Pressure Gauge 12 doesn't work	A. Clogged inlet of the Pressure Gauge	A. Unscrew and remove the Gauge, then clear any obstructions in its inlet.
	B. Faulty Pressure Gauge	B. Contact our Customer Service.
8. Sand ended up in the pool	A. The sand is too small for the Pump	A. Use only #20 grade silica sand with particle size range 0.45-0.85 mm (0.018-0.033 inches) and uniformity coefficient less than 1.75
	B. The sand bed is calcified	B. Discard all the used sand and replace with new sand.

# 6-port Valve Parts List

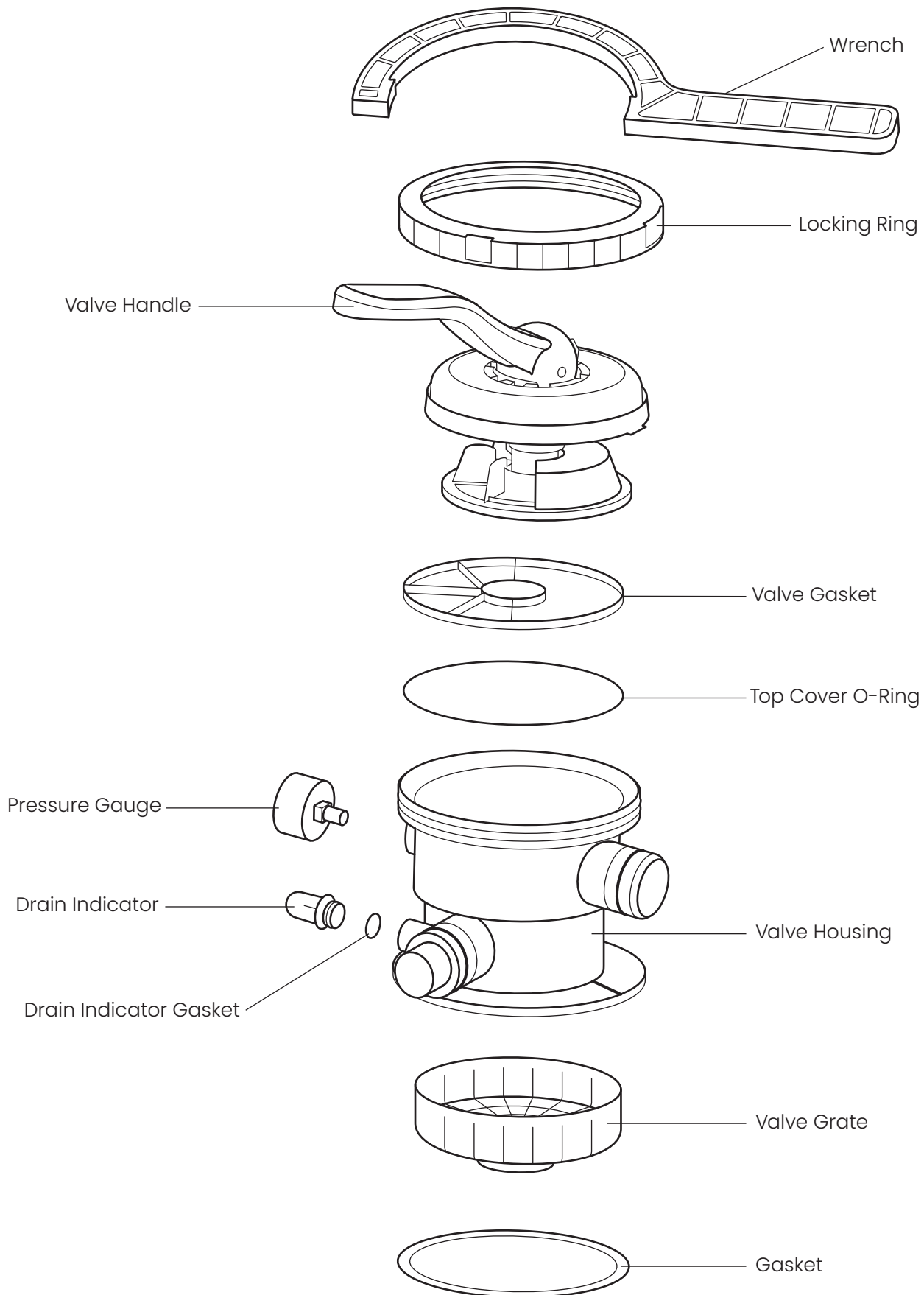

# 6-port Valve Setup

1. Using the Wrench, twist counterclockwise to loosen and remove the Locking Ring.

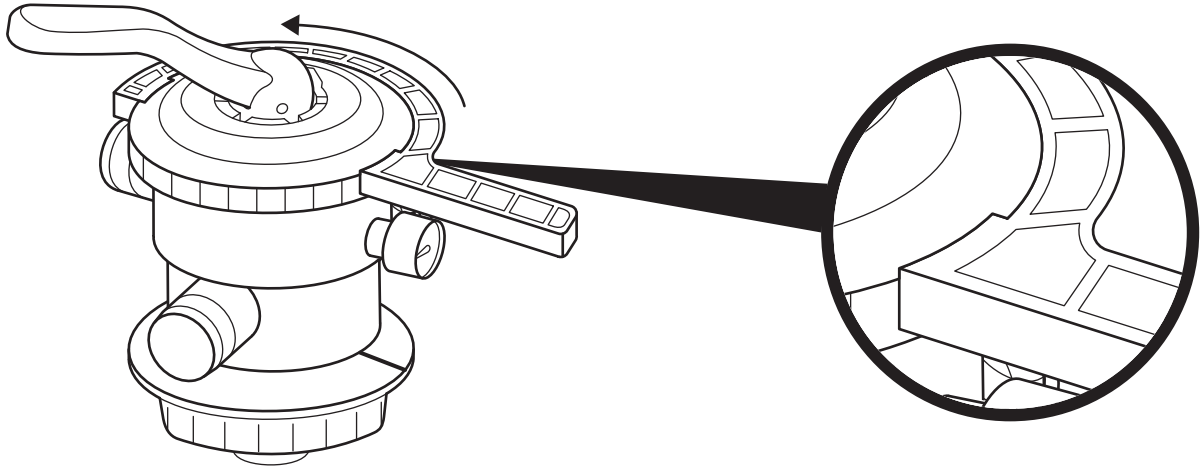

2. Fit the Gasket in place.

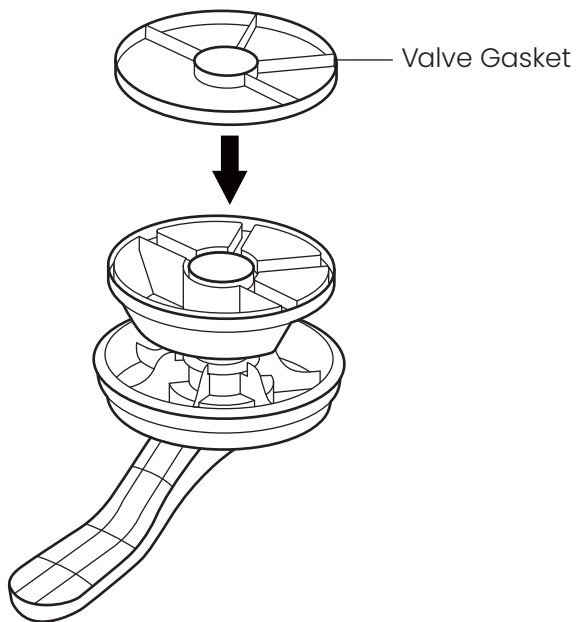

3. Insert the Top Cover O-Ring into the groove of the Valve Housing.

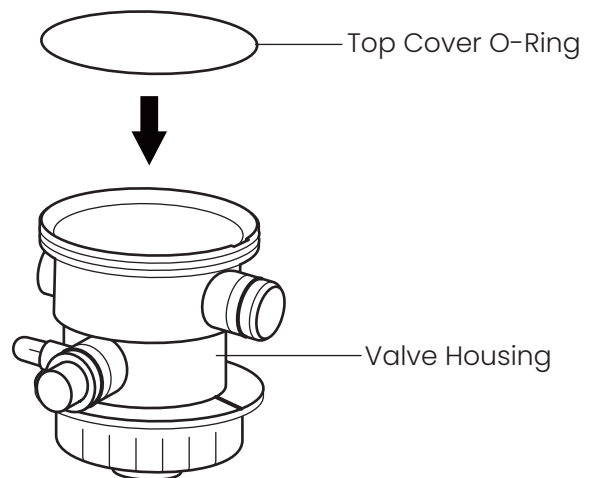

4. Insert the Valve Handle into the Valve Housing.

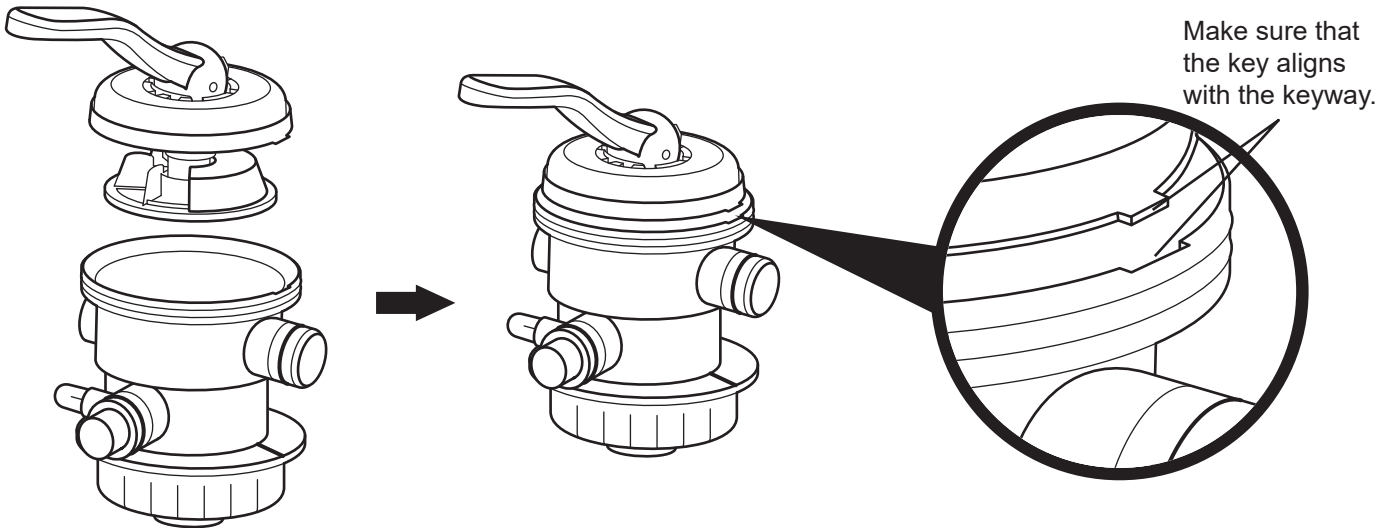

5. Place the Locking Ring over the Valve Housing.

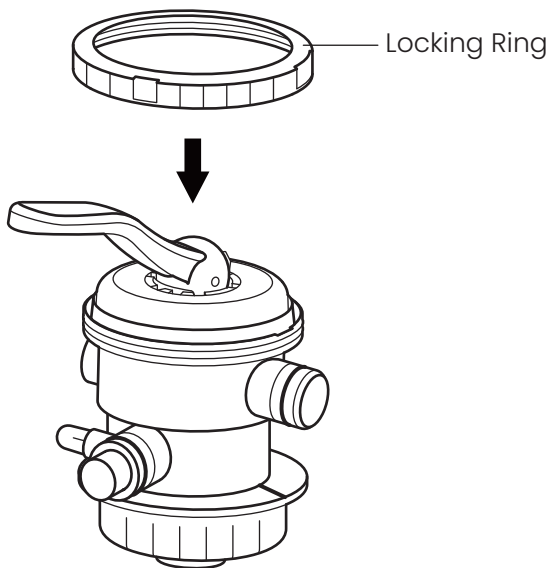

6. Tighten the Locking Ring with the Wrench.

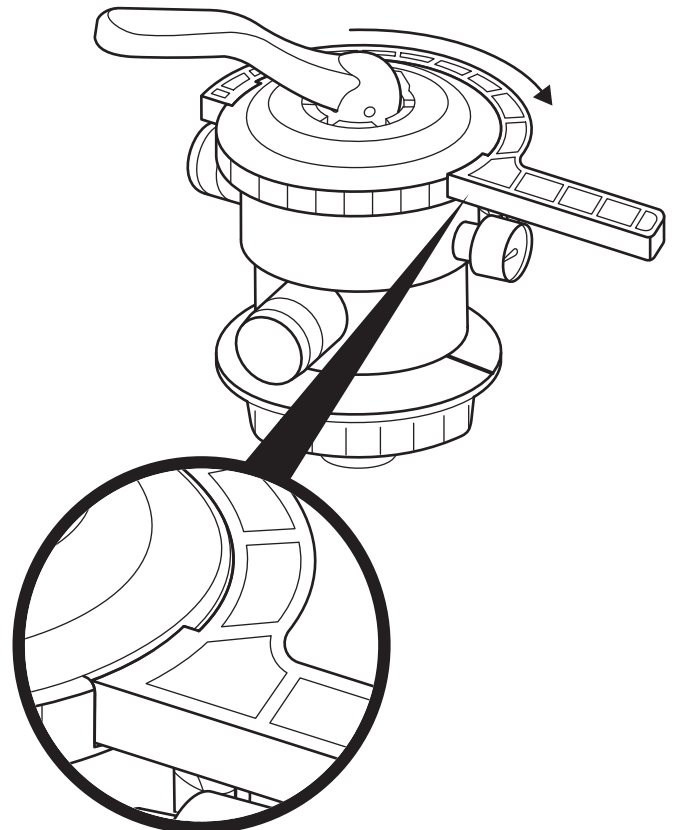

# Asme Compliant Suction Fitting Information

## PSF-2021A and PSF-2021B Suction Outlet Fitting (For Aboveground Pool)

- PSF-2021A and PSF-2021B Suction Outlet Fittings are certified by IAPMO in accordance with the ASME/ANSI/APSP/ICC-16 2017 **Suction Fittings for Use in Swimming Pools, Wading Pools, Spas, and Hot Tubs.**
- This is a submerged suction outlet fitting for use with aboveground swimming pool.
- For dual drain only. TWO outlet fittings are used for each pump.
- Do not locate these suction outlet fittings on sitting areas or on the backrest for such seating area.
- Install this outlet fittings at location recommended by the pool manufacturer. Maximum height 1.8 m from the ground.
- The maximum allowable flow rate of PSF-2021A is 28 gallons per minute (1,680 gallons per hour) and PSF-2021B is 34 gallons per minute (2,040 gallons per hour).
- Connection hose:
  - a. Model PSF-2021A is to be connected with 1 ¼" (31.8mm) diameter hose.
  - b. Model PSF-2021B is to be connected with 1 ½" (38.1mm) diameter hose.
- The suction outlet fitting is to be mounted at the suction outlet fitting opening as specified by the manufacturer of the aboveground pool. The diameter of this opening should be within the range of 1.875" (47.625mm). Refer to the following diagram for detailed assembly instructions:

### For pump included with the pool:

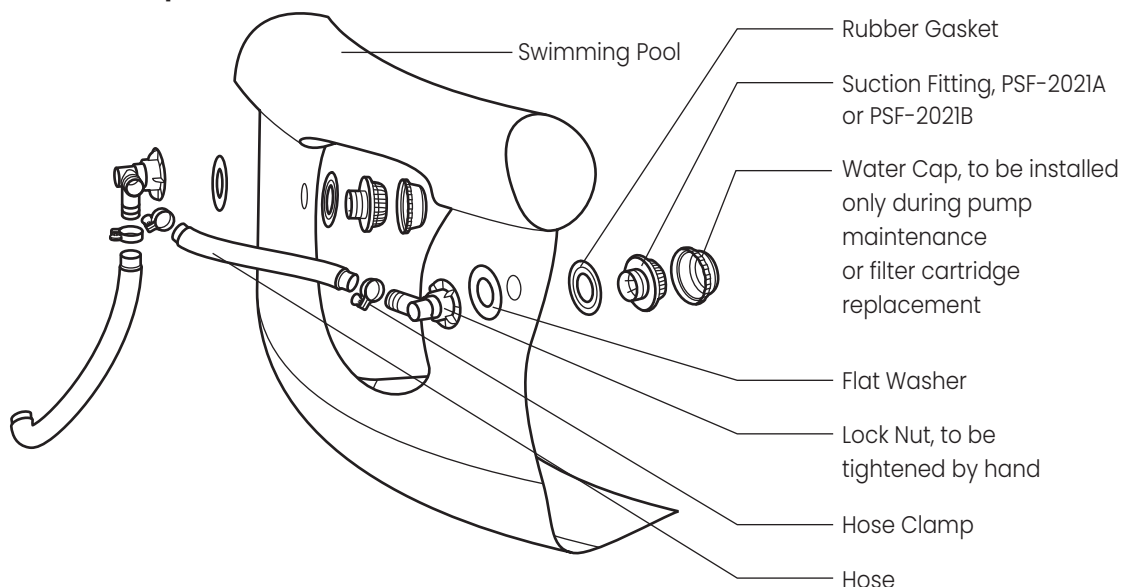

### For pump sold separately:

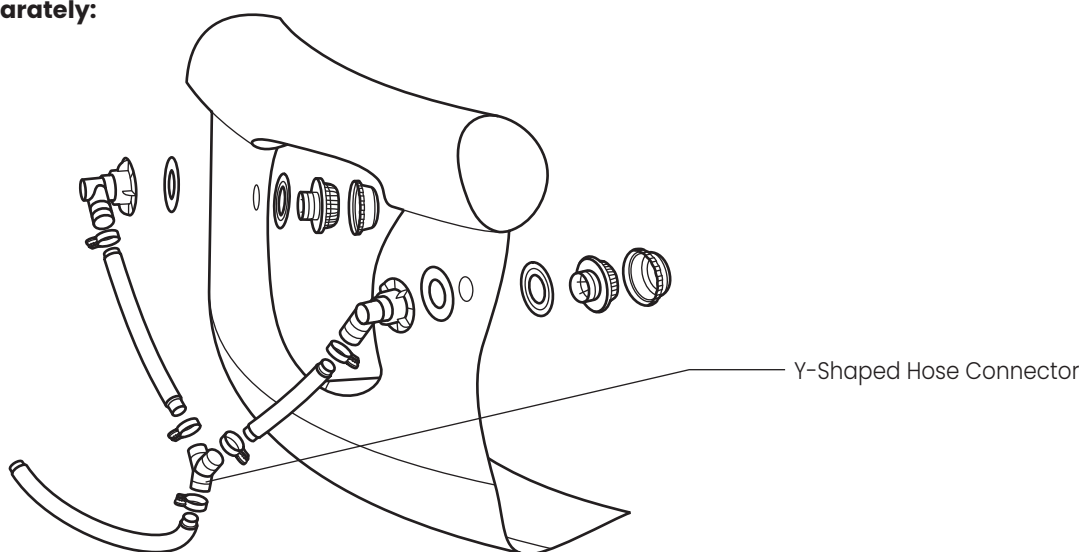

- PSF-2021A or PSF-2021B Suction Outlet Fitting is to be replaced every 3 years.
- No tool is required for installation.
- Service & winterizing instructions:
  - a. CAUTION! DO NOT EXCEED THE MAXIMUM ALLOWABLE FLOW RATE: 28 gallons per minute (1,680 gallons per hour) for PSF-2021A and 34 gallons per minute (2,040 gallons per hour) for PSF-2021B.
  - b. Carefully observe and inspect the suction outlet fitting for damage and tampering. Missing, broken or cracked suction outlet fitting must be replaced before each use of your pool.
  - c. Loose suction outlet fitting should be reattached or replaced before each use of your pool.
  - d. Remove and store the suction outlet fitting assembly if temperatures are expected to fall below 32°F (0°C).

## Important Information about Suction Outlet Fitting Assembly (SOFA)

**WARNING! This is a BLOCKABLE VGBA Suction Outlet that must ONLY be installed in a multiple VGBA Suction Outlet system.**

- When installing and using this equipment, basic safety precautions shall always be followed, including the following: IMPORTANT SAFETY INSTRUCTIONS.
- READ, FOLLOW, AND UNDERSTAND ALL INSTRUCTIONS AND WARNINGS.
- Any modification that increases the flow rate of the circulation system shall require reevaluation of the cover/grate and sump to ensure that the flow rating of the Suction Outlet Fitting Assembly (SOFA) is not exceeded.
- All SOFA components must be replaced in every 3 years.
- According to Section 6.2.2 of «ANSI/APSP/ICC-16 2017», the Suction Outlet Fittings of this pump are categorized as blockable type.
- Any field modifications made to a SOFA not authorized by the manufacturer's installation instructions shall void the SOFA certification.
- No modification shall be made to a SOFA structure or flow path unless the new configuration has been certified as new SOFA.
- Cover/grates and all other SOFA components shall be replaced at or before the end of their service life (3 years) and that service life begins the month and year in which a SOFA component is installed with or without water.
- Cover/grate, including fasteners, shall be observed for damage or tampering each operational day.
- Missing, broken, or cracked cover/grates shall be replaced before bathers are allowed to use the pool.
- Loose cover/grates and associated components shall be reattached before bathers are allowed to use the pool.
- SOFA components and fastener receptacles shall be clean and free of debris or obstructions during installation of cover/grate and fasteners.
- It is required to hand-check cover/grate for snugness to the sump/frame after installation.
- Regular visual and hand-check of SOFA components is required to ensure there is no color change, cracks, deformation, missing parts or components with pieces broken off. Replace the SOFA if there is color change, cracks, deformation, missing parts or broken pieces.
- The General Certificate of Conformity (GCC) is available at the following website: [www.funsicle.com](http://www.funsicle.com).

## Installation Requirements and Limitations for Suction Outlet Fitting Assembly (SOFA)

- All SOFAs shall be installed in accordance with the manufacturer's installation instructions, or for RDP SOFAs, in accordance with the registered design professional's engineering plans.
- No modification shall be made to a SOFA structure or flow path unless the new configuration has been certified to the original SOFA.
- The performance-based flow ratings for all SOFA(s) are tested with standard «ANSI/APSP/ICC-16 2017». These flow limits are designed to prevent suction entrapment.
- Compliance with this standard requires that these SOFA-configuration specific flow ratings NOT be exceeded at any time the pool is open to bathers.
- Compliance with this standard requires selecting and installing a SOFA, or combination of SOFAs, such that the resulting individual suction system flow rating is greater than the pumping system's maximum system flow rate.
- The flow rating for pools with multiple, blockable SOFAs piped together in one body of water without isolation valves shall be determined by combining the flow rating of all SOFAs, minus the flow rating of one. If the flow ratings of all SOFAs are not equal, subtract the flow rating of the SOFA with the highest flow rating. SOFAs are not intended for single application and are not unblockable. Flow rating: PSF-2021A: 28 GPM; PSF-2021B: 34 GPM.
- The cover/grate for this pump is "For Use in Storable Pool Only". The cover/grates, when installed, shall not protrude more than 2 inches (51 mm) from the finished surface of the pool in which the SOFA is installed.
- When used in multiple-outlet systems, cover/grates marked blockable shall be arranged such that the two outermost sumps/frames shall have a minimum separation of three feet, measured center-to-center. If they are to be installed closer than three feet center-to-center, they shall be located on two different planes, i.e., one SOFA shall be located on the pool floor, and one shall be located on a vertical wall, or one SOFA shall be located on each of two separate walls.
- The Suction Outlet Fitting Assembly (SOFA) has been certified to the consumer product safety rule applicable to SOFAs, which is covered in the Virginia Graeme Baker Pool and Spa Safety Act «ANSI/APSP/ICC-16 2017».

[This page is intentionally left blank.]

## Dear Funtastic Customer,

Thank YOU for choosing one of our Funsicle products. We're on a mission to inspire the world to play more outdoors, which is why we design products that capture the summertime spirit of imagination, connection and fun.

It's important to us that you have the BEST experience with this product, and we're excited for you to make some happy outdoor memories.

Need a helping hand? Use the contact info on this page to reach us.

Once again, we thank you for placing your trust in us. Happy swimming and playing!

- Your friends, the Funsicle Team

## CONTACT US

We're here to help! For answers to common questions, setup videos and troubleshooting tips, visit [funsicle.com/support](https://funsicle.com/support) or scan the QR code.

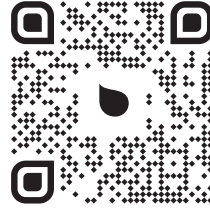

### DO NOT RETURN PRODUCT TO STORE.

If you encounter any issues with your Funsicle product, do not return it to the place of purchase.

Contact CUSTOMER SERVICE:

**Phone: 888-670-4FUN (888-670-4386)**

**Email: [HelloFun@Funsicle.com](mailto:HelloFun@Funsicle.com)**

### WARRANTY

For warranty information, visit [funsicle.com/warranty](https://funsicle.com/warranty).

### NEED PARTS?

To order parts and accessories, visit [funsicle.com](https://funsicle.com).

### REGISTER YOUR PRODUCT

Scan the QR code

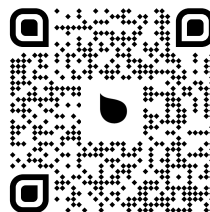

# Funsicle®

### Distributed by:

Polygroup Pacific Limited  
Unit 606, 6th Floor, Fairmont House,  
8 Cotton Tree Drive, Central, Hong Kong.