



# COVERS GUIDE



EST.  1907

**FRIESENS**  
MEMORIES CRAFTED IN PRINT  
— EMPLOYEE-OWNED —



# CONTENTS

|                            |    |
|----------------------------|----|
| PREPARING ARTWORK          | 2  |
| COVER OPTIONS              | 5  |
| CRYSTALLINE                | 9  |
| TEXTURED LINE              | 10 |
| SPECIAL ORDER MATERIALS    | 10 |
| EMBOSSSED GRAINS           | 11 |
| FOIL STAMPING              | 12 |
| EMBOSSING                  | 13 |
| STOCK COVER SHOWROOM       | 14 |
| STOCK COVERS AND ENDSHEETS | 15 |
| ADDITIONAL STOCK ENDSHEETS | 37 |
| STOCK EMBOSSSED COVERS     | 41 |
| STOCK METAL INLAYS         | 44 |

# PREPARING ARTWORK



# ARTWORK CAN BE SUPPLIED IN A FEW WAYS

## CUSTOM COVER

An original drawing or painting can be mailed to us, which we would then scan with our high quality scanner, create a digital file and add any text or design elements you would like on the cover.

Supply digital images that we will place on a cover template in the arrangement as per your instructions and add any text you would like on the cover.

Supply Friesens with your digital file, created in one of our supported programs. We will then make any adjustments necessary to fit the cover/spine size for your yearbook.

## STOCK COVER

If choosing a stock cover design, just email your Project Specialist the stock cover name and the text you would like on the cover. A school crest or logo may also be added.

### PROGRAMS SUPPORTED BY FRIESENS FOR SUPPLYING DIGITAL COVER FILES:

- Adobe Photoshop 3.0 and higher
- Adobe Illustrator 4.0 and higher
- Adobe InDesign 1.5 and higher
- CorelDRAW 7.0 and higher

## PLACEMENT OF PERSONALIZING

Personalizing is normally placed in the bottom right hand corner of the cover. Other placements may be possible but must be confirmed by your Project Specialist prior to submission.

## POINTS TO REMEMBER

- Choose ink colours from a Process Colour Guide, not from your monitor. Monitors tend to display false colours.
- Always submit all fonts and images you have used to create your cover.
- All digital image files need to be saved as TIFF, JPG, PNG, EPS or PSD format, with a resolution of 300 DPI (dots per inch) at actual size.
- Full colour covers need to be saved in CMYK format.
- If supplying Photoshop files, please leave in layers so minor adjustments can be made by Friesens to make sure your artwork will fit the cover template.
- For areas that are to have spot UV coating or embossing, you can create a separate layer indicating so, or supply us with instructions as to which elements should have the effect applied.
- Using clear, precise instructions will eliminate the chance of your cover artwork being produced in the wrong way.
- Note that the cover size for any hard cover book is not the same size as the inside pages. The cover extends past the pages and includes a hinge area on either side of the spine. InDesign cover templates can be found on ConnectMe, or you can request one from your Project Specialist. We can also supply you with Photoshop templates to help you create artwork at the perfect size.
- Endsheets are the same size as a double page spread in your yearbook.

# COVER PROOFING

After you have submitted your cover and endsheet files to your Friesens team, our Prepress reviews the files and prepares them for a final proof. Our Prepress will do their best to ensure your spine width is correct, and will complete any additional design requests at this time. Your proof will arrive as an email or a physical package. This year, you may also be able to proof your cover on ConnectMe - contact your Project Specialist for more details.

We will confirm your order quantity, cover materials and treatments at final proof time. Before returning your cover or endsheet proofs to your Project Specialist, please review and check the following:

- Is the spelling correct?
- Is the spine text aligned properly?
- Are all dates or years noted correctly?
- Do you have any special applications to your cover (embossing, spot gloss, foil)? If so, are they represented correctly on the files?

## SAMPLE COVER TEMPLATE

BACKFRONT

**HINGE/GUTTER AREA:**  
This is the area between the cover board and the spine. It gets “smashed” in during binding. Type and important elements should not be placed in the hinge area.

**WRAPAROUND AREA:**  
This area will be wrapped around the cover board to the inside and the endsheet will be glued over top. Anything that you would like to appear on the cover should not be in this area. Any images or background colours that are to bleed off the cover should fill this area.

**SPINE:**  
This is the area that will show when your book is on a bookshelf. Usually your school name and year can be placed here, as well as the book title if you wish. For an English book, the spine text should start at the top and read towards the bottom. Spine text runs the opposite way for a French book.

The following pages show samples of cover options available to you. The samples are actual covers designed by schools and are not available as stock designs.

# COVER OPTIONS



# PROCESS COLOUR

One or more ink colours are applied to paper for limitless design potential. Any artwork, photographs or digital designs can be printed with this process. For durability and protection, a plastic lamination is applied with either a gloss or matte finish.

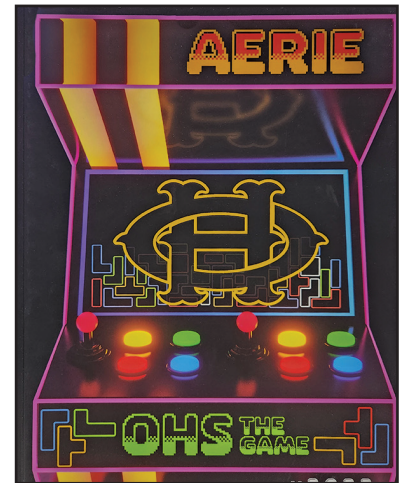

# QUARTER BINDING

For a classic traditional look, no other application brings it all together like quarter binding. Quarter binding utilizes two colours of material – either two different types of material, or is imitated by using a different colour of ink on the same material.

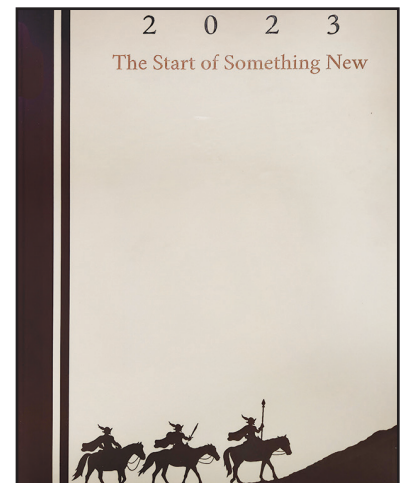
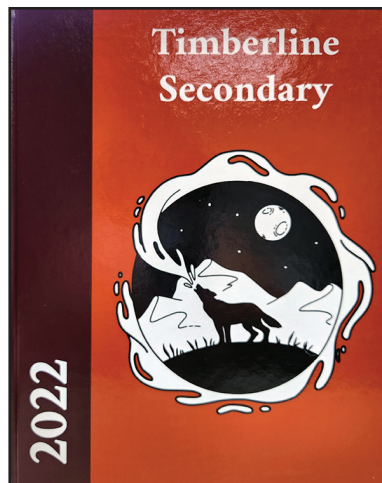
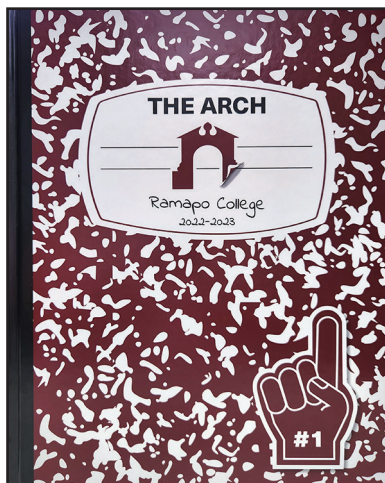



## EMBOSSING

An embossed cover uses a brass die to press a design into the cover to raise specific areas. Debossing uses a similar die to indent specific areas. You can create your own design or use one of our pre-made stock designs. When embossing, you have the option of requesting a grain at no charge. (see page 8 for grain samples)

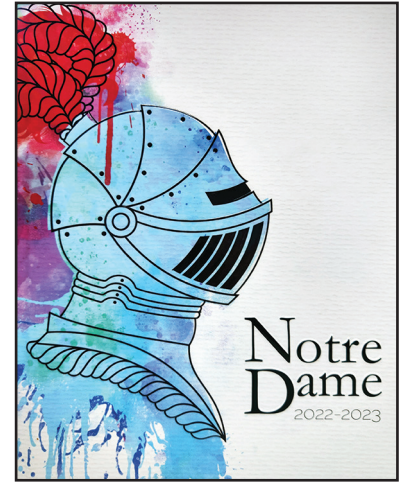
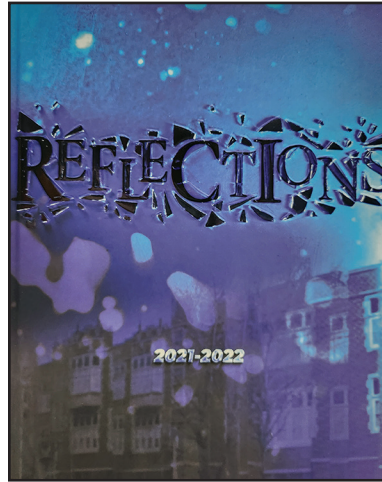

## FOIL STAMPING

Add style to your cover by presenting your cover artwork in foil rather than ink. Foil stamping adds a dynamic flair to your cover and can highlight important elements of your design.

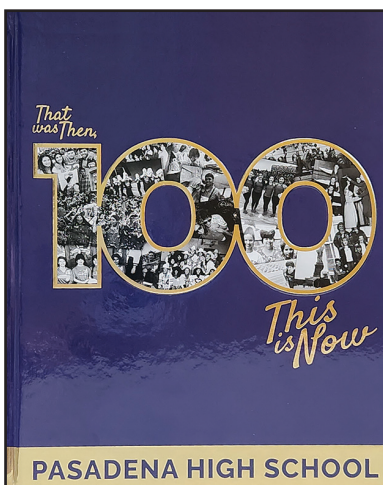

## 3D METAL INLAY

A metal inlay is an application that combines a layer of metal with sculptured embossing for a very special effect. Metal inlays are available in six colours including: gold, silver, copper, blue, green and red.

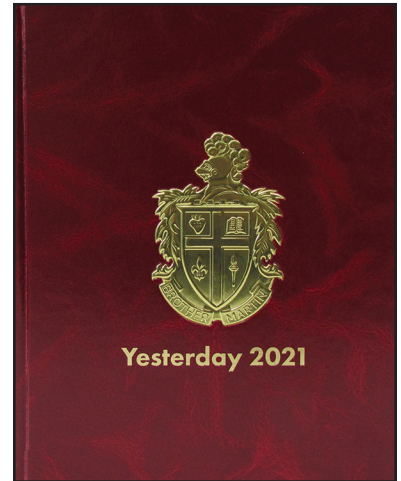
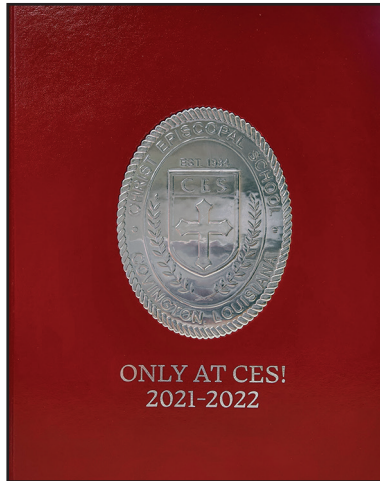
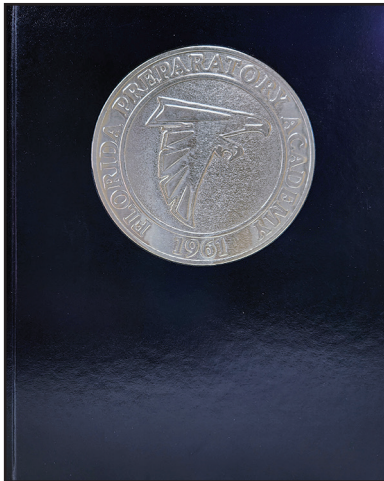

## DIE CUTTING

Growing in popularity, die cutting is the process of cutting a pre-designed shape directly through the cover. When the yearbook is closed, the endsheet can be seen through the die-cut opening in the cover. Note that diecut shapes should be kept fairly simple and may need to be modified in order to produce the best product

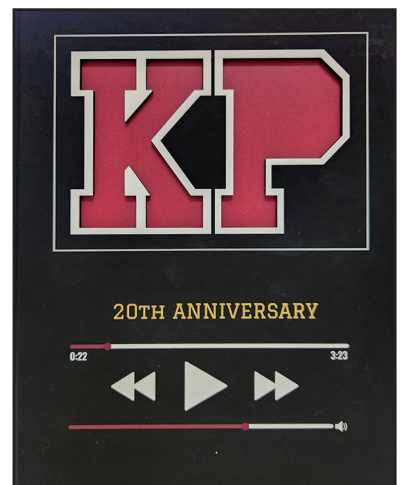
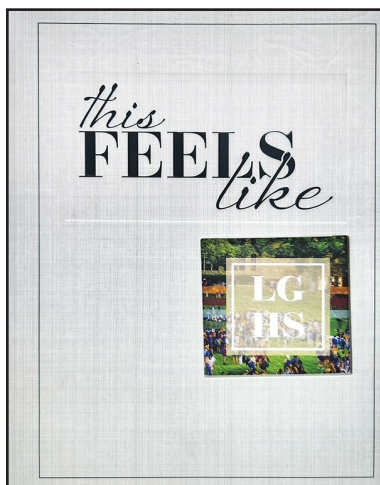

# CRYSTALLINE

Crystalline covers are printed on white paper using an offset or digital press, and then laminated for durability and protection. They have a nearly limitless design potential and can have several other applications applied to them.

- Choose from gloss or matte
- Apply a spot UV coating to highlight design elements in a glossy finish
- Apply a linen weave embossing for a canvas like texture
- Emboss or deboss areas as well as add a grain
- Foil stamp text or design elements
- Apply a metal inlay

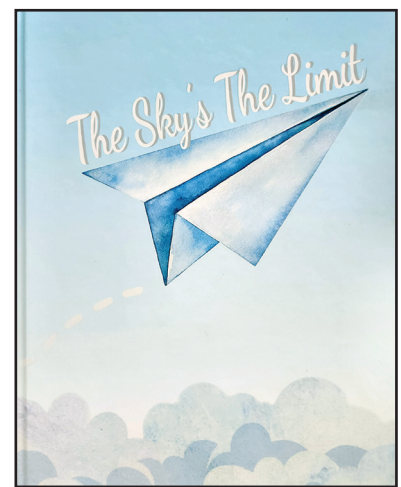
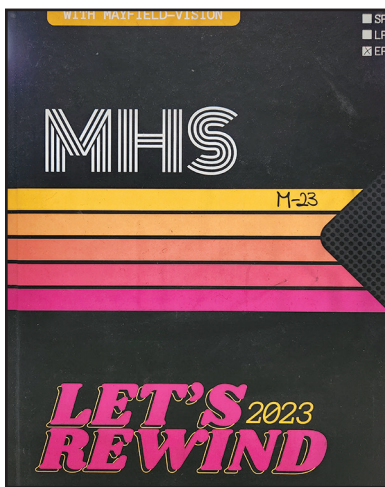
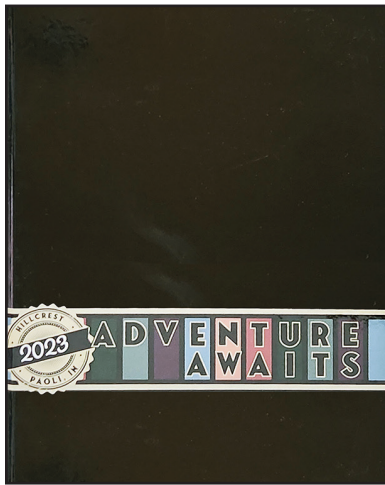

## TEXTURED LINE

Textured Line offers a leather-like alternative to Crystalline. Like Crystalline, the Textured Line cover material is included in the base price of a hard cover yearbook. Textured Line is used to achieve a traditional looking cover. Designs for Textured Line covers should use clean, simple lines with not a lot of fine detail. Application options include:

- Silkscreen solid areas of ink in almost any color including metallic silver and gold
- Emboss or deboss areas as well as add a grain
- Quarter binding two colours of textured stock to achieve a traditional look
- Apply a metal inlay
- Foil stamp text or design elements

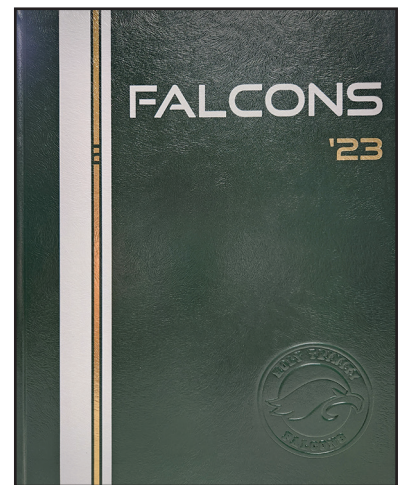
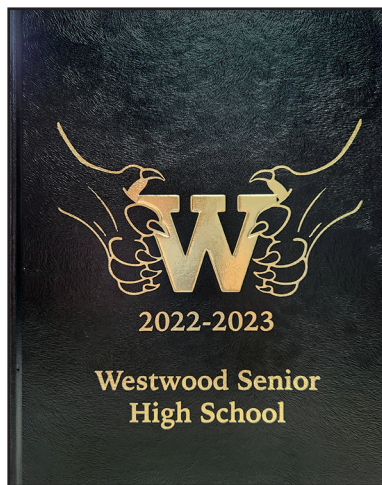
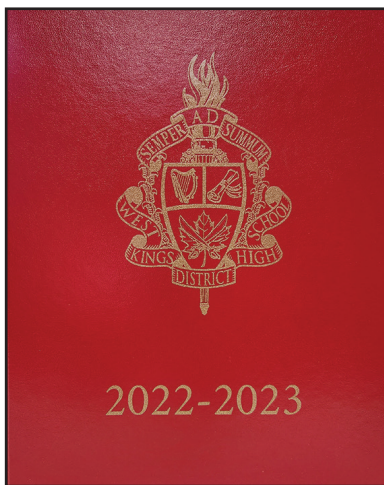

## SPECIAL ORDER MATERIALS

Friesens offers several special order cover materials. Sueded, Tanalin, Brillianta, Pearl Linen and Rainbow are a few of the cover materials available upon request. These materials have minimum quantity requirements and carry additional charges. Check with your Yearbook Consultant for pricing.



# EMBOSSSED GRAINS

Embossed grains can be applied to both Crystalline and Textured Line covers. If your cover already has some custom embossing, the grain can be added for no additional charge. To view textures directly, check out the Cover Swatch booklet.

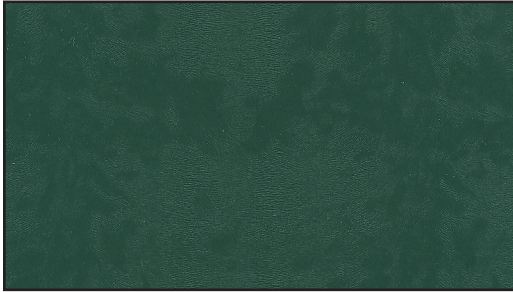

**FOX FUR**

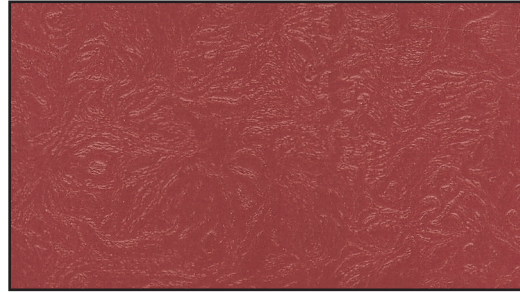

**LAVA**

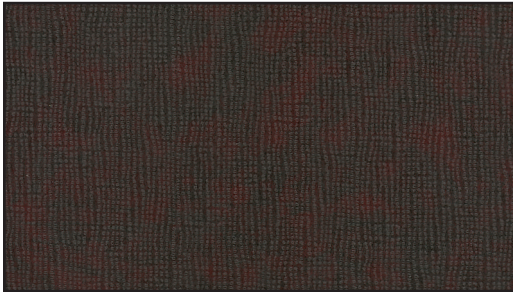

**BURLAP**

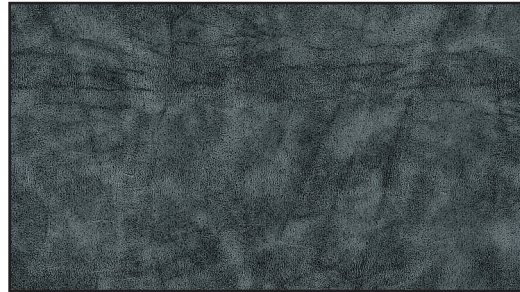

**MISSION**



**PEOPLE**

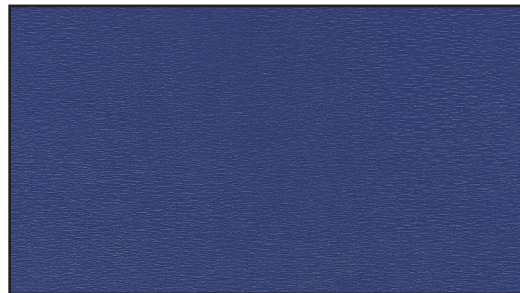

**PIGSKIN**



**WALRUS**

# FOIL STAMPING

Foil stamping is a very popular method of applying traditional cover designs. It can add class and style to the right cover design. Many schools choose to combine foil with one or more silkscreen ink colors or a full process color cover for a unique effect. The two standard foil colours are gold and silver but there are many other available for special order.

There are many design possibilities when using foil but there are also some guidelines to remember. The foil is applied by heat and pressure to the cover and in order

to achieve proper adhesion, your design should avoid any large, solid areas. Clean, well defined lines work best. Avoid designs with a lot of detail and very fine lines because the foil may fill in these areas and the detail could be lost. Any design using foil on the back cover uses a larger die, therefore the cost is greater.

Check with your Yearbook Consultant to make sure the design you've chosen will work successfully with foil, and for a cost estimate.

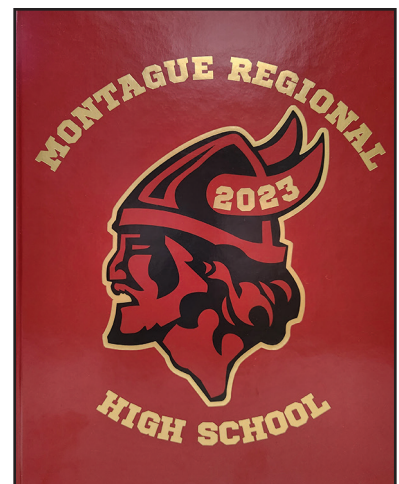
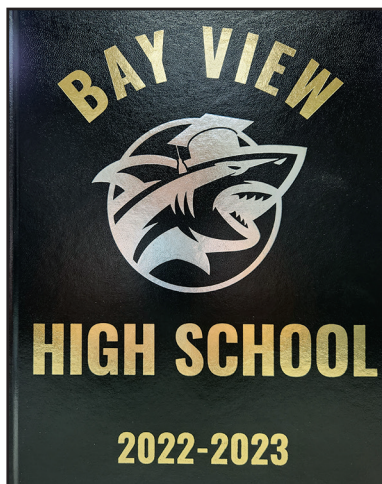
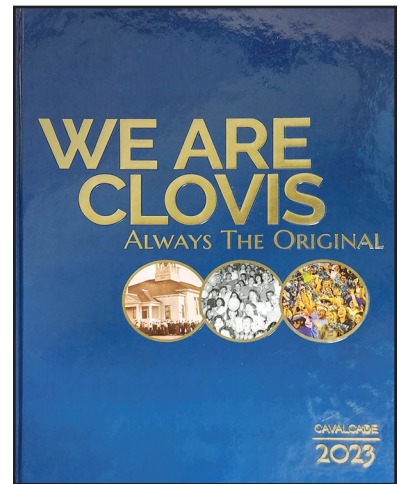
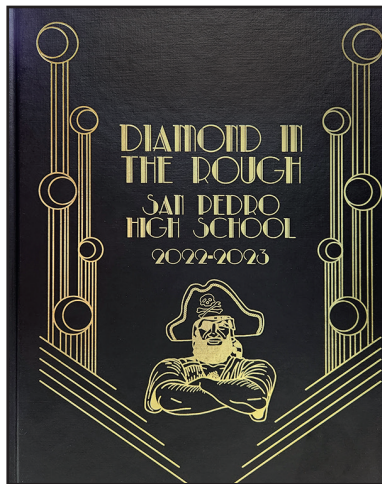
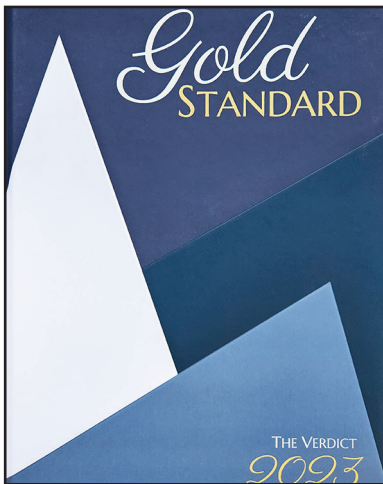

# EMBOSSING

## EMBOSSING OPTIONS

- **Flat Embossed:** Embossing artwork is raised to one level. Artwork and text may be printed within the raised area. The text can be included in the raised area or formed as individual raised letters outside of the raised area.
- **Debossed:** Similar to embossing, but the design is pressed into the cover, rather than raised. Same rules apply.
- **Multi-level Flat Embossed:** Embossing artwork can be raised to a few different levels, or items debossed to appear pressed in the cover.
- **Sculptured Embossed:** The raised image area has a definite three dimensional look and feel. If ink is not applied to the 3D area, it is referred to as blind embossing.
- **3D Metal Inlay:** This application combines the application of a heavy foil and a sculptured embossing. The effect can be compared to the look of a metal coin.

## COVER BOARD WEIGHT

Hard cover 8.5" x 11" yearbooks use a standard 100 pt. board in the cover. For 9" x 12" books, and some of our specialty packages, 120 pt. is the standard weight. Embossed covers use a 150 pt. board. A thicker cover board gives the book more bulk and protection. Heavier board can be specially ordered for any hard cover book

## PERSONALIZATION

The cover area used for personalizing will be a flat area with no grain added. This will eliminate the chance of the foil breaking up and make the type easier to read.

## CUSTOM DIES

Ask Friesens to store your custom embossing die so that it can be used year after year, saving you the cost of ordering new dies.

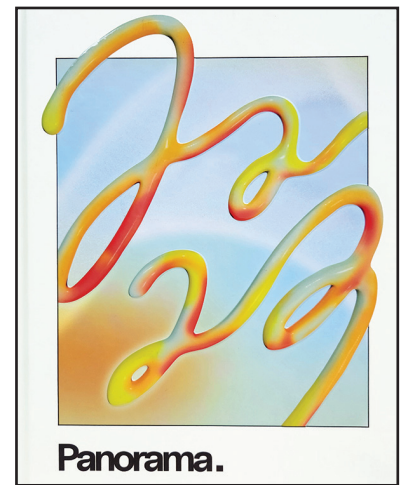

# STOCK COVER SHOWROOM





# STOCK PROCESS COLOUR COVERS & ENDSHEETS



23-BRICKS

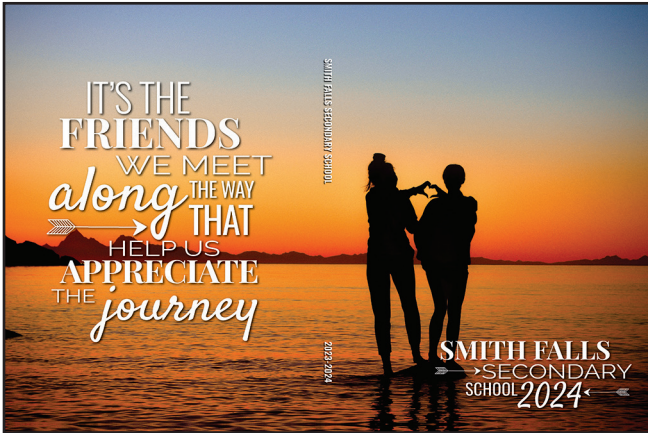

23-FRIENDS



23-MYSTERY

# STOCK PROCESS COLOUR COVERS & ENDSHEETS



23-NOW SHOWING

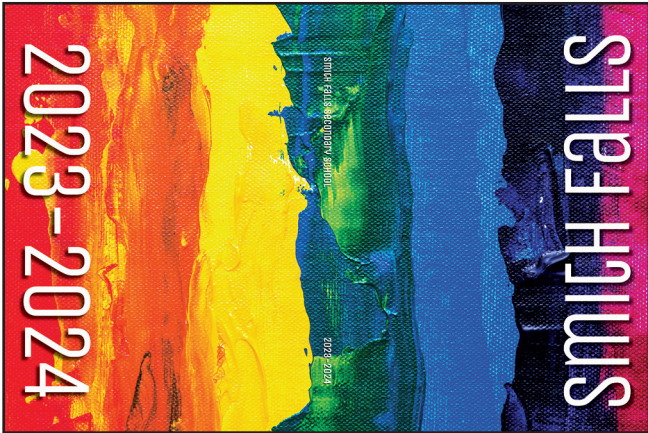

23-PAINT THE TOWN

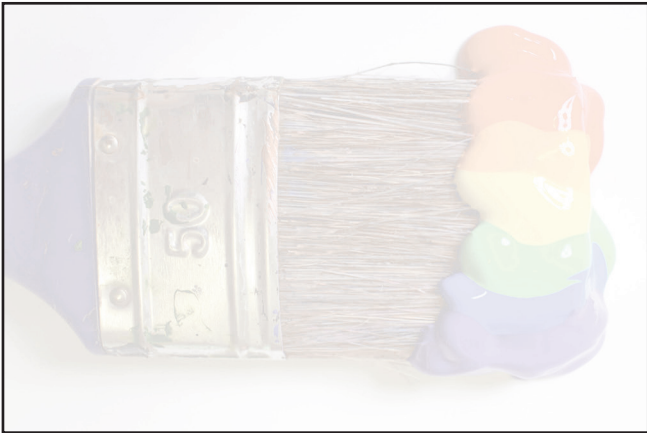

23-SAY CHEESE



# STOCK PROCESS COLOUR COVERS & ENDSHEETS



23-SCRAPBOOK

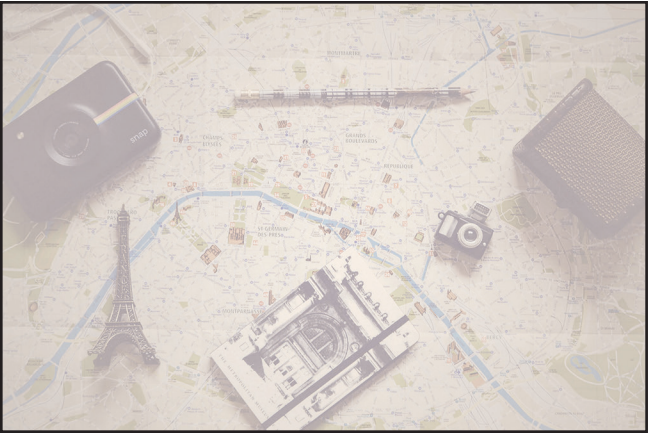

23-STAY TUNED

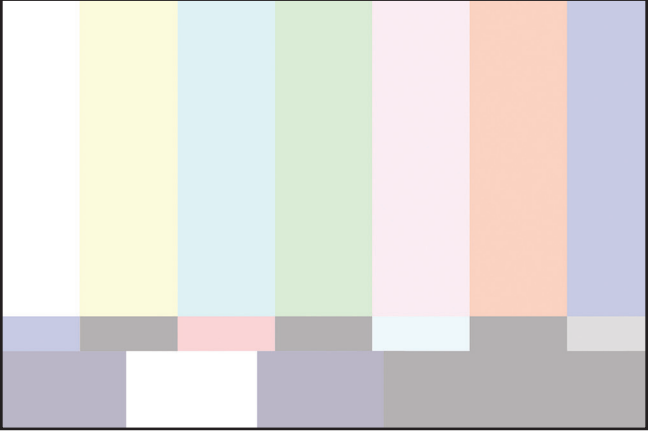

23-SUMMER VIBES



# STOCK PROCESS COLOUR COVERS & ENDSHEETS



23-YOU'VE GOT MAIL

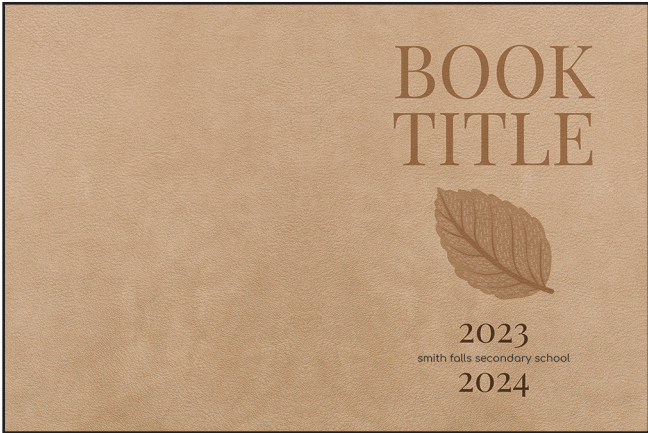

22-ART DECO

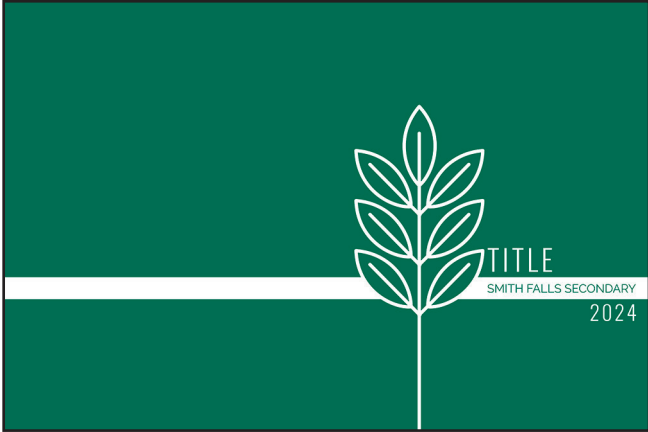

22-BROCHURE

# STOCK PROCESS COLOUR COVERS & ENDSHEETS

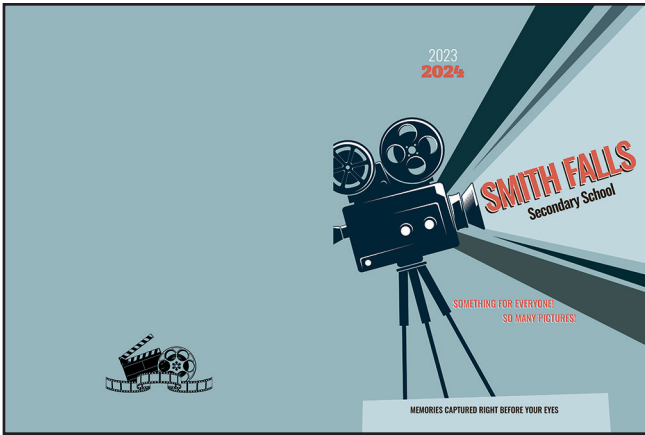

22-FILM SCHOOL

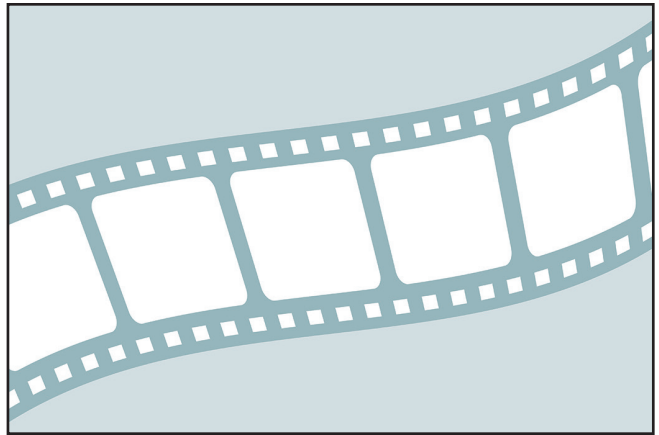

22-GRID FADE

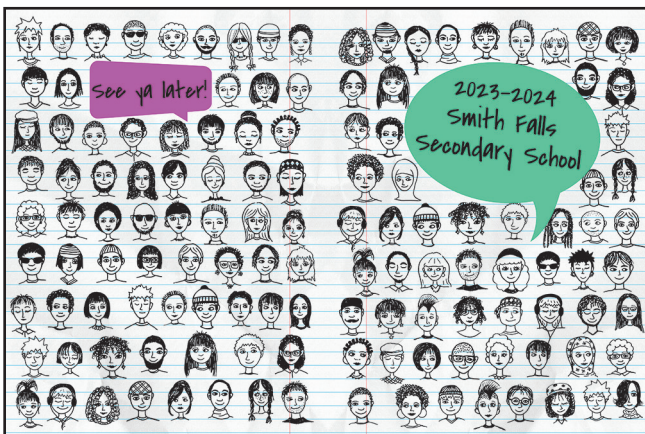

22-NOTE PAPER



# STOCK PROCESS COLOUR COVERS & ENDSHEETS

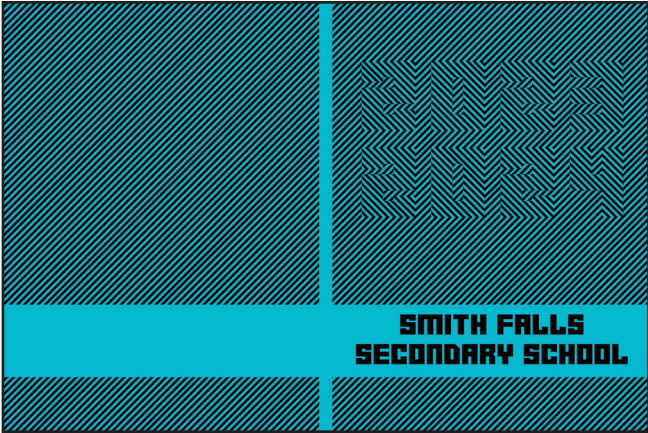

22-OPTICAL ILLUSION

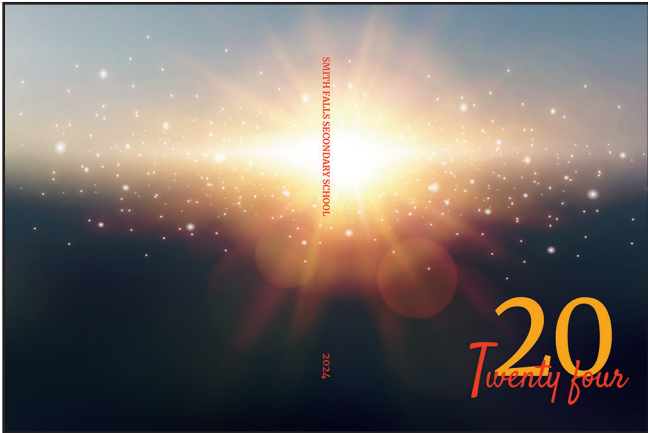
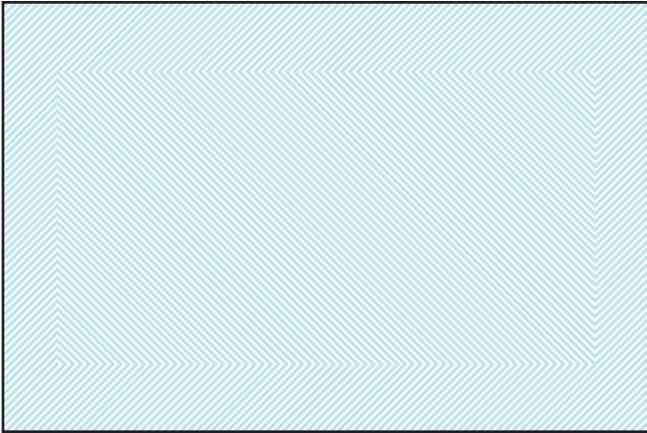

22-OVERLAY



22-PUZZLE BYTES



STOCK PROCESS COLOUR COVERS & ENDSHEETS



22-REFRACTION

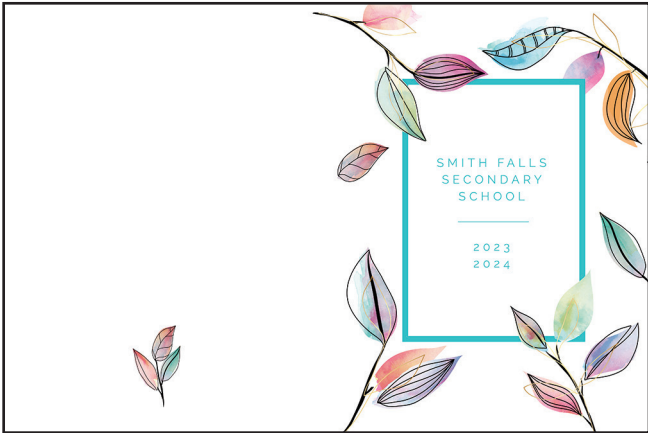
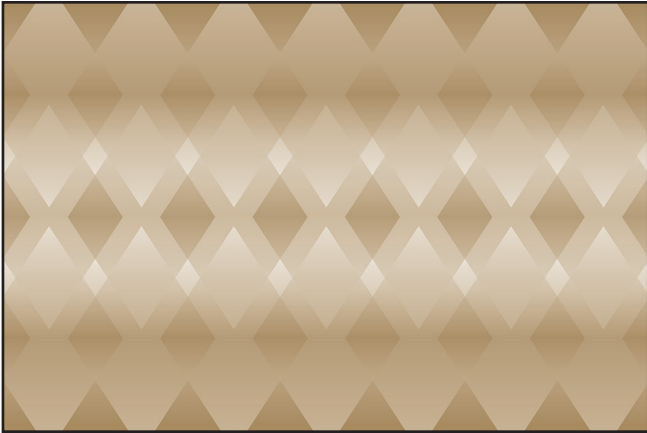

22-RENEWAL

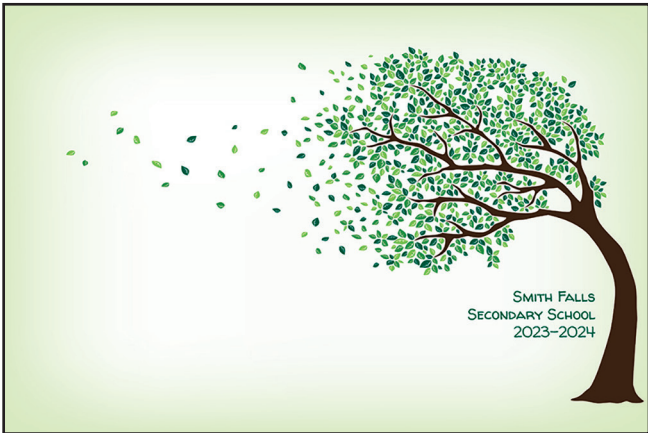

22-RESILIENT



# STOCK PROCESS COLOUR COVERS & ENDSHEETS



22-SHINE



22-SHOCK

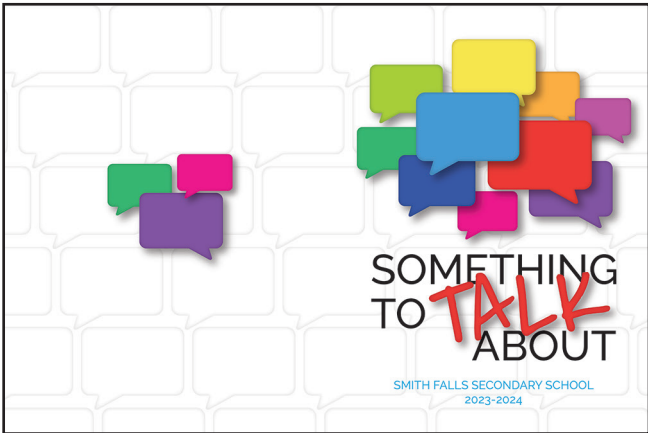
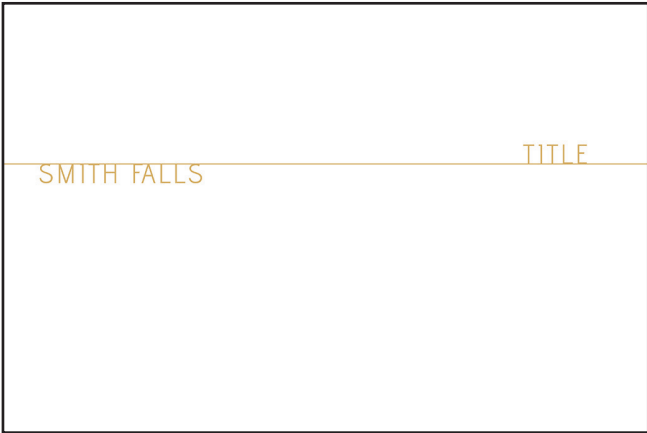

22-SOMETHING TO TALK ABOUT





STOCK PROCESS COLOUR COVERS & ENDSHEETS



22-STEP INSIDE



22-STRIPES

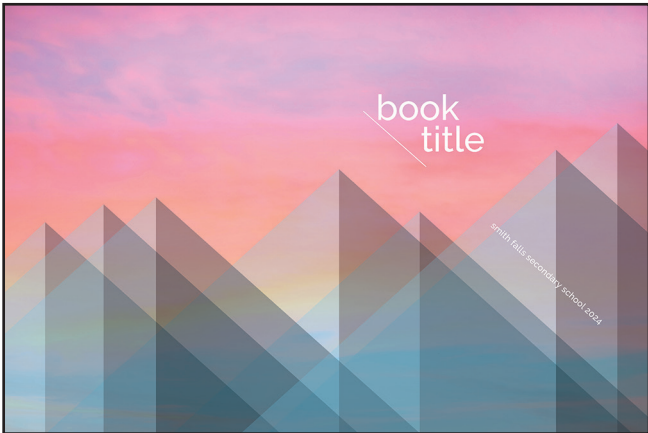
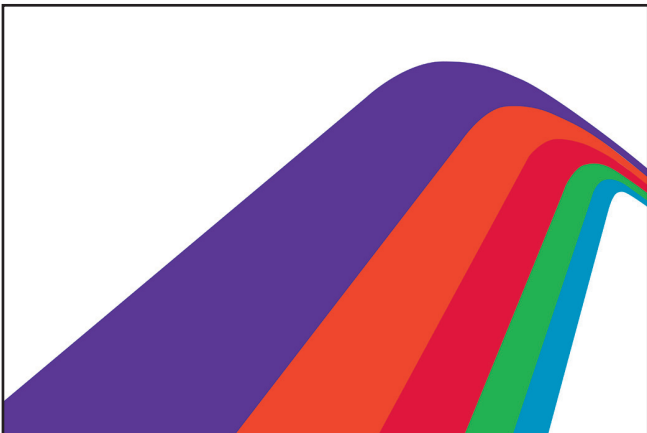

22-TESSERACT

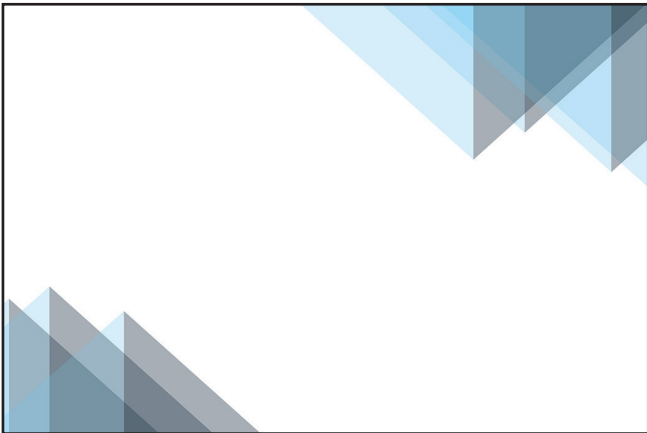

# STOCK PROCESS COLOUR COVERS & ENDSHEETS



22-VIOLET LIGHT

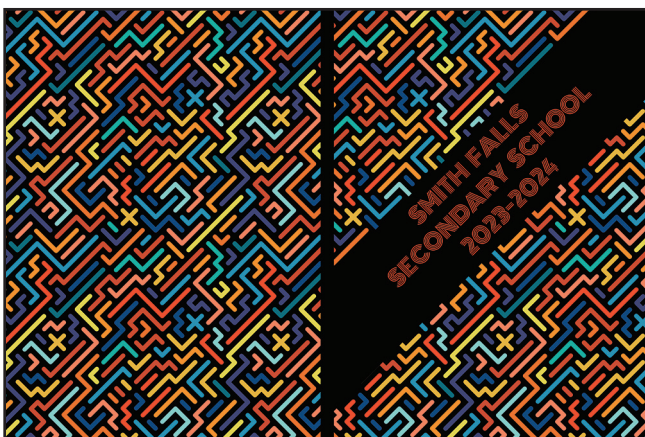

21-A-MAZED



21-AS IF



# STOCK PROCESS COLOUR COVERS & ENDSHEETS



21-BUTTERFLIES

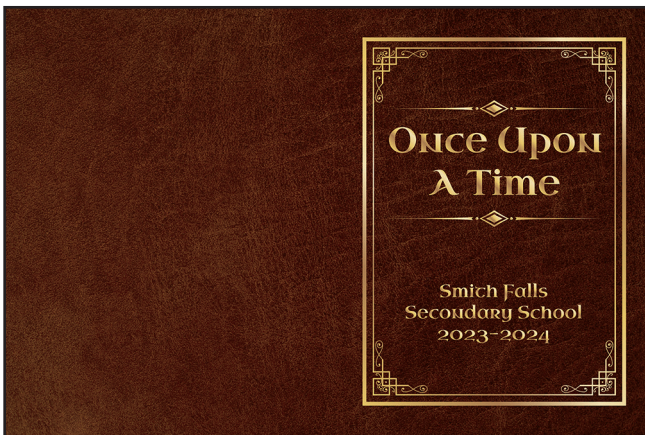
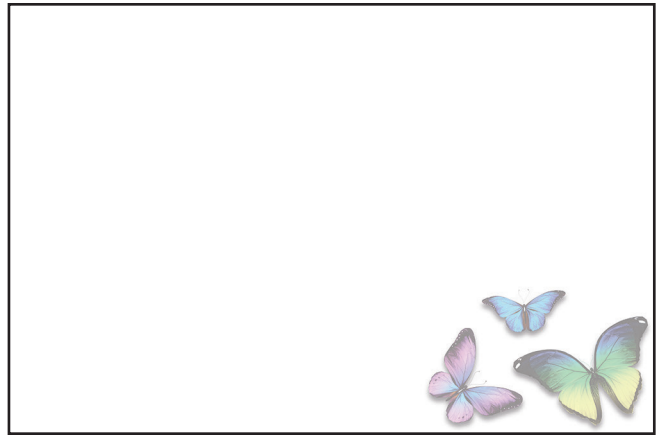

21-FAIRYTALE



21-MIXED EMOJIS

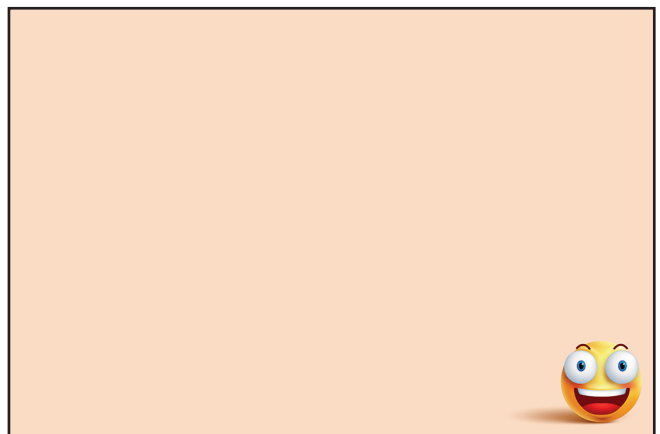

# STOCK PROCESS COLOUR COVERS & ENDSHEETS



21-ROCKET MAN



20-HERO



20-JEANS

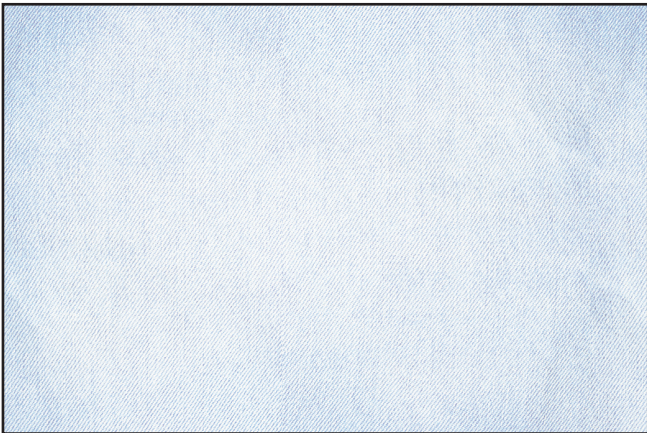

# STOCK PROCESS COLOUR COVERS & ENDSHEETS



20-KAPOW

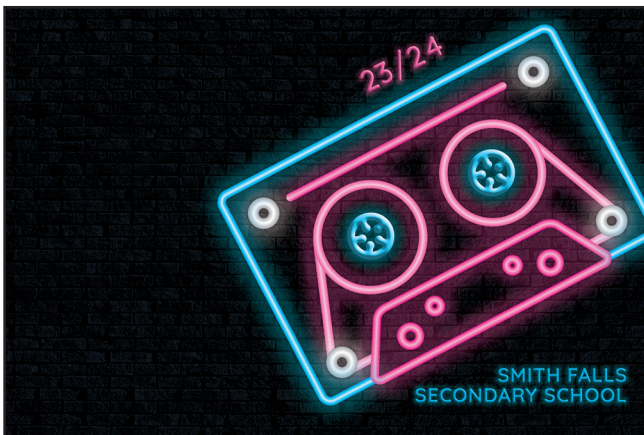
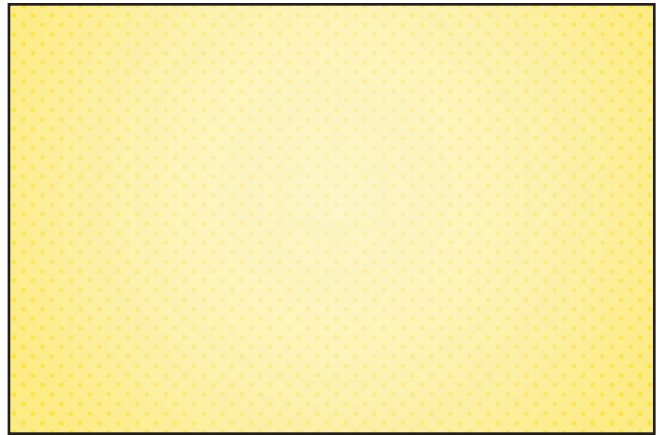

20-MIX TAPE

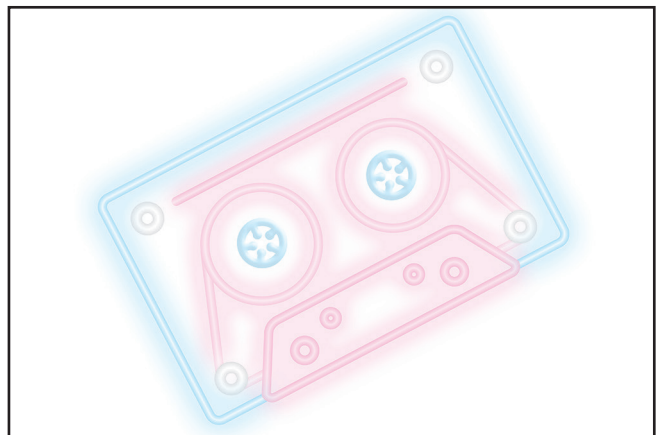

20-TAPESTRY

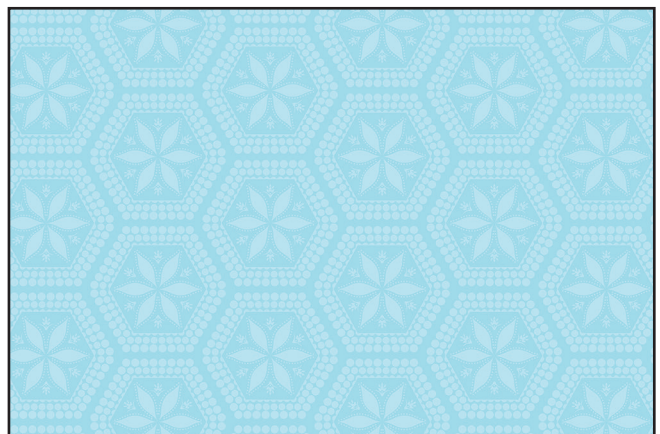

# STOCK PROCESS COLOUR COVERS & ENDSHEETS

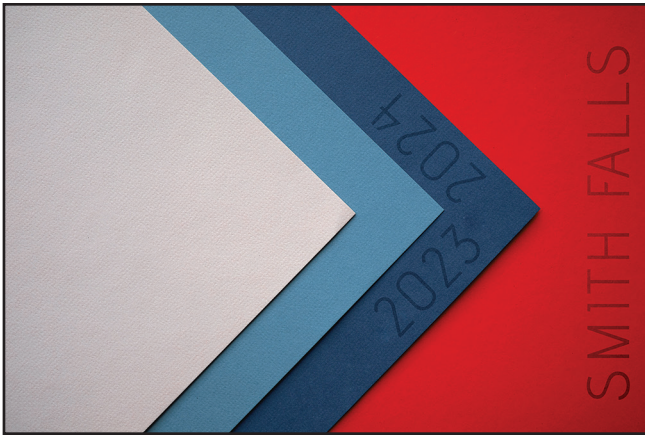

20-THE RIGHT DIRECTION

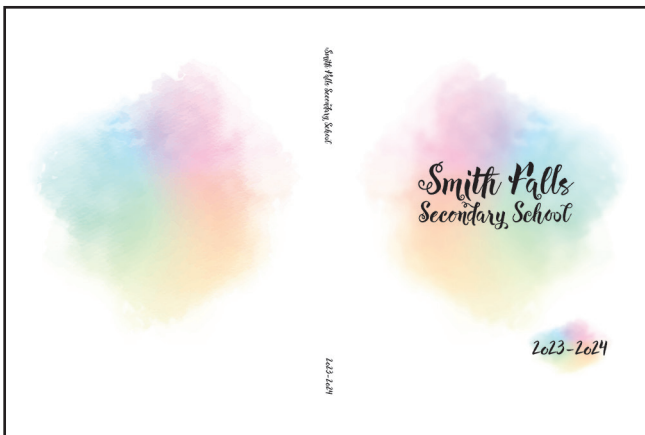
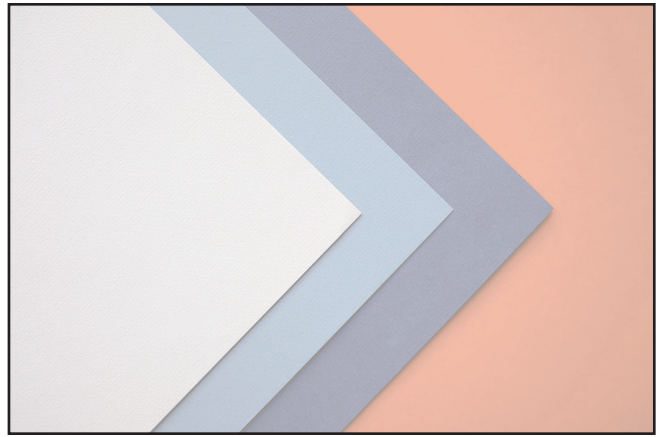

19-RAINBOW

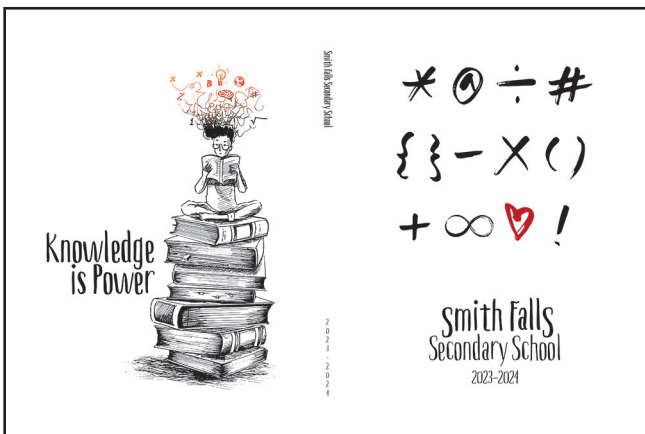

19-KNOWLEDGE



# STOCK PROCESS COLOUR COVERS & ENDSHEETS

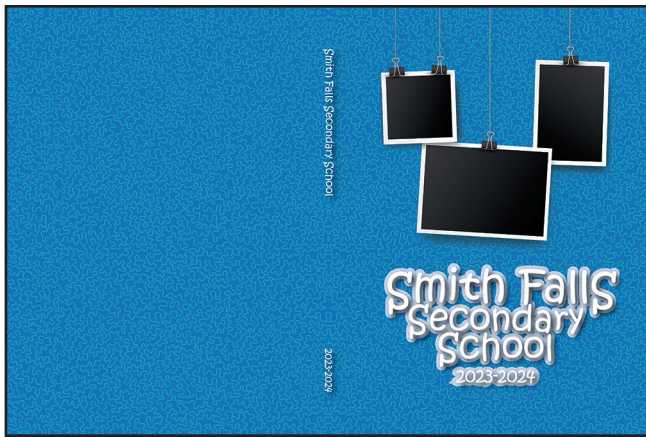

19-BY A THREAD



19-ACRYLIC



18-CRAFTED 1



# STOCK PROCESS COLOUR COVERS & ENDSHEETS



18-KALEIDOSCOPE

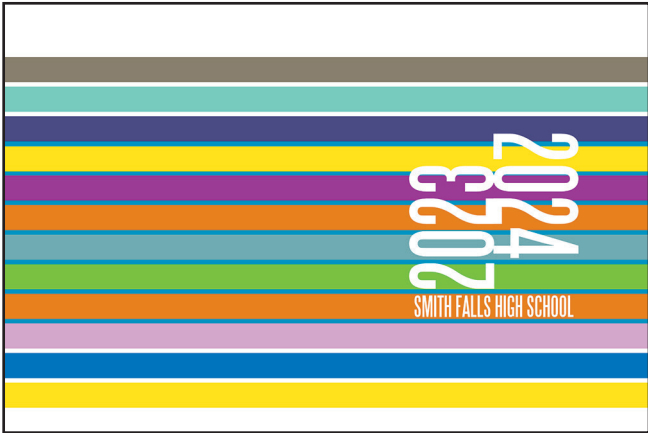
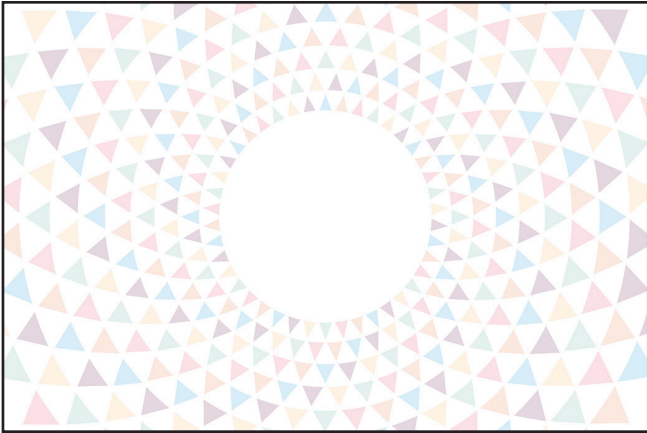

18-MAYPOLE 1

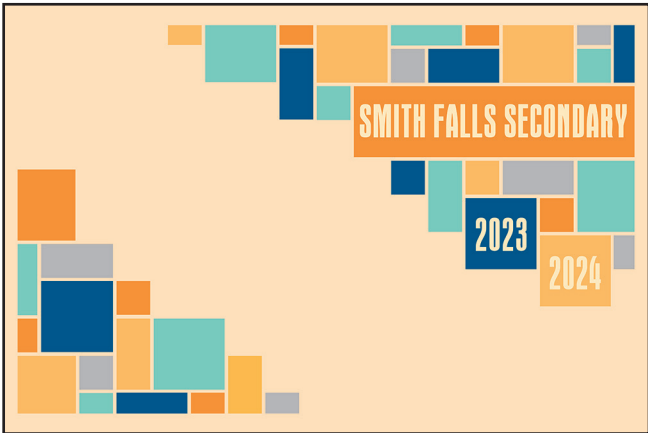
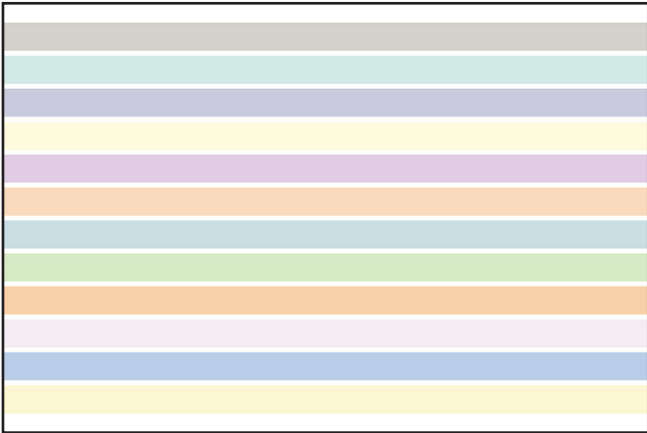

18-RETRO RECTANGLES

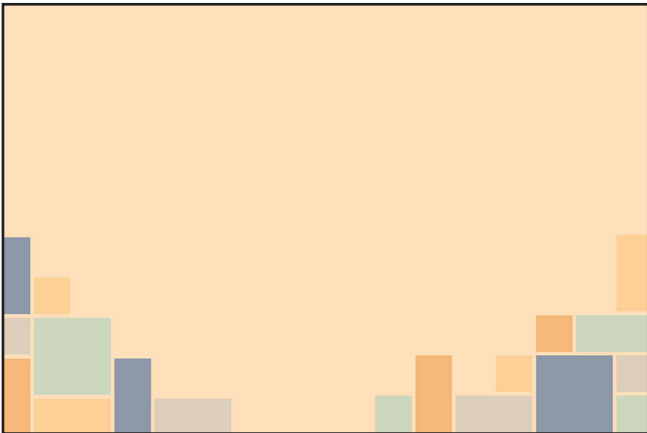



# STOCK PROCESS COLOUR COVERS & ENDSHEETS



18-TRILOGY

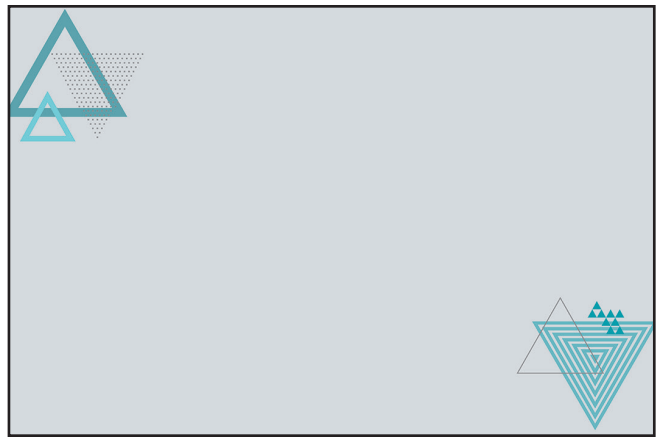

17-ACES



17-RETRO RAINBOW

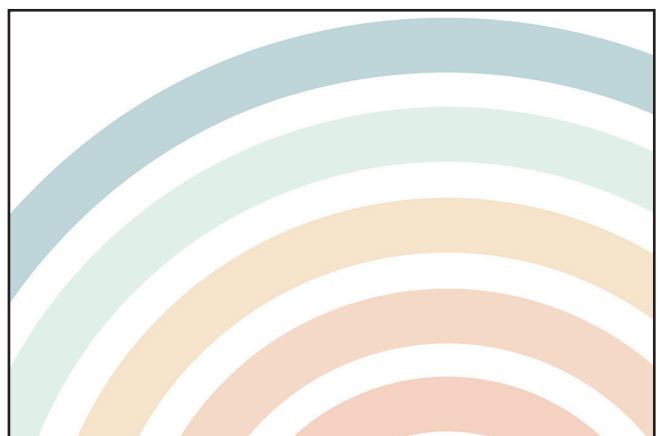

# STOCK PROCESS COLOUR COVERS & ENDSHEETS



17-WHAT WE ARE 1970



17-WHAT WE ARE 1980



16-BULLETIN BOARD



# STOCK PROCESS COLOUR COVERS & ENDSHEETS

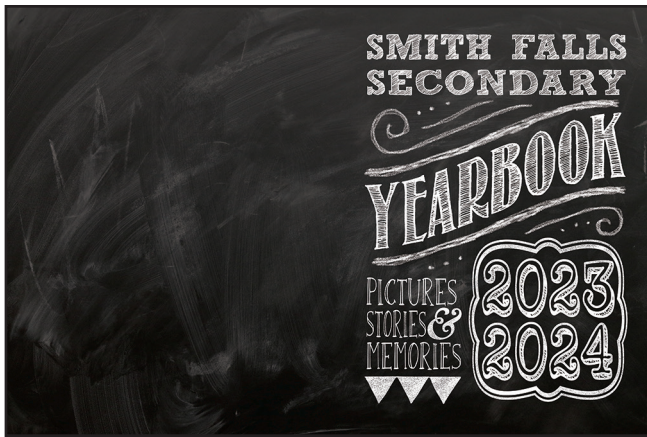

16-CHALKBOARD

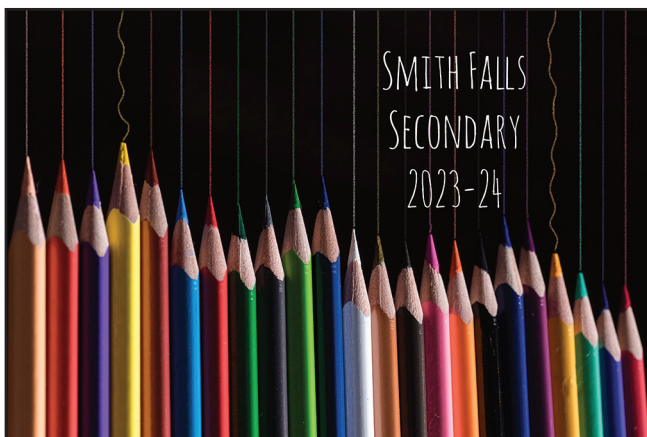

16-TRUE COLOURS



16-CONCRETE



# STOCK PROCESS COLOUR COVERS & ENDSHEETS

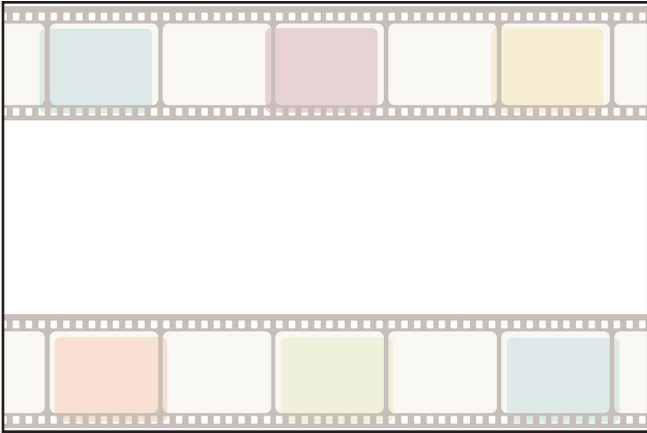
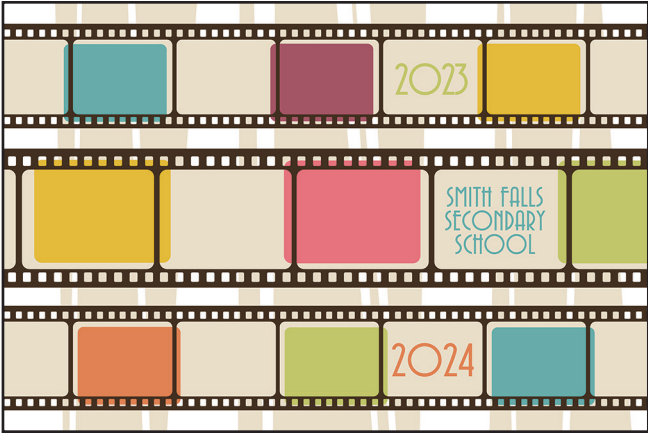

16-FILMSTRIP



16-JOURNEY

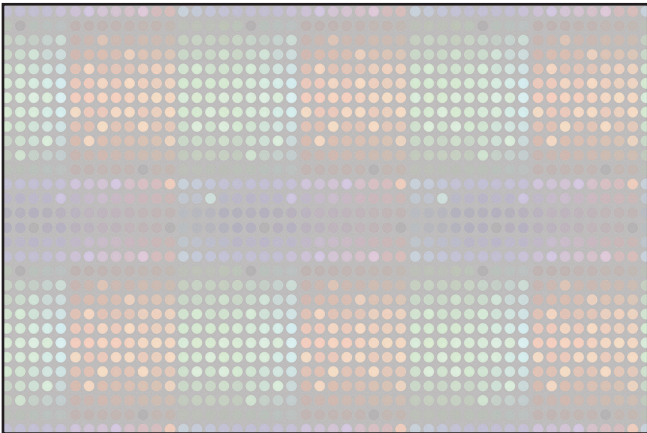
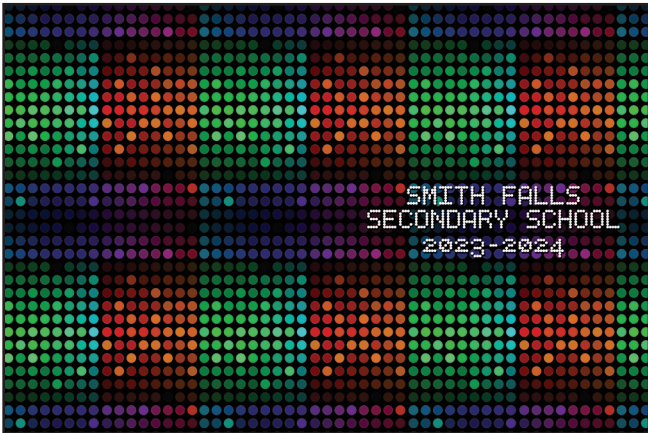

16-LOTSA DOTS

# STOCK PROCESS COLOUR COVERS & ENDSHEETS



16-OFF THE RECORD



16-SODA

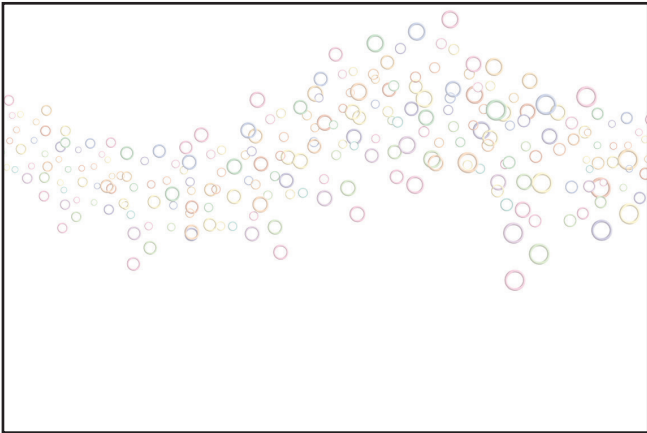

16-SOUNDTRACK

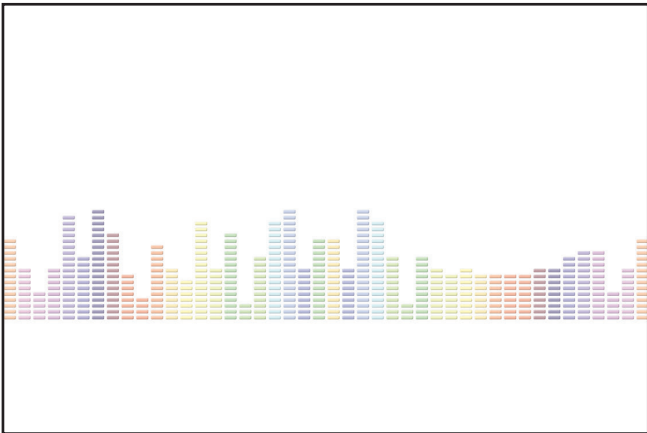

# STOCK PROCESS COLOUR COVERS & ENDSHEETS



16-UNDER THE SEA



16-UP AND AWAY



16-WALK A MILE

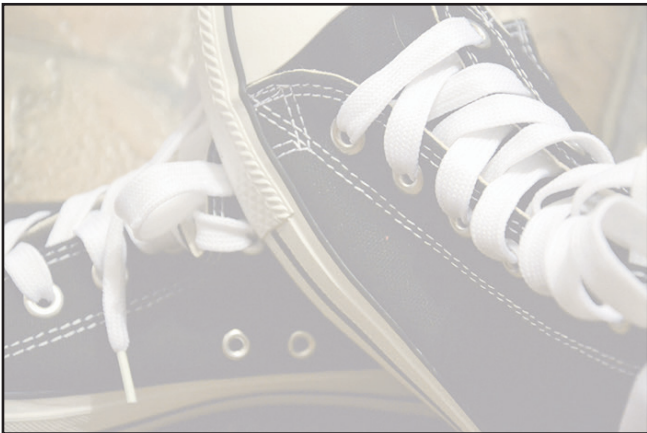

## ADDITIONAL STOCK COLOUR ENDSHEETS

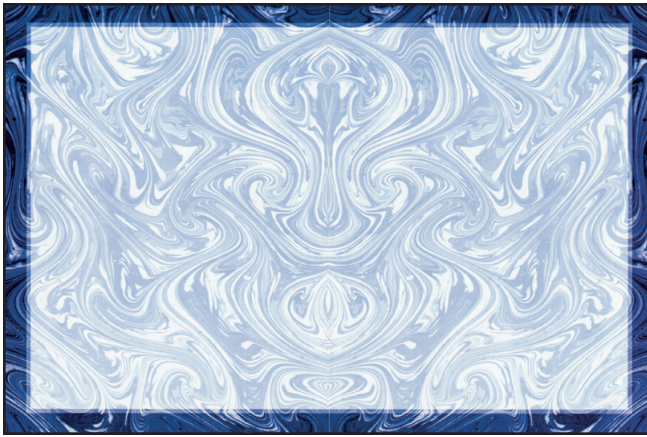

**04-SWIRLS**



**06-ANTIQUE BOOK**

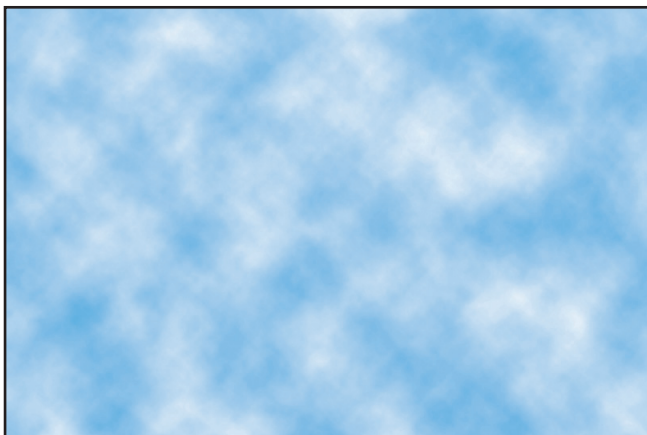

**04-CLOUDS**

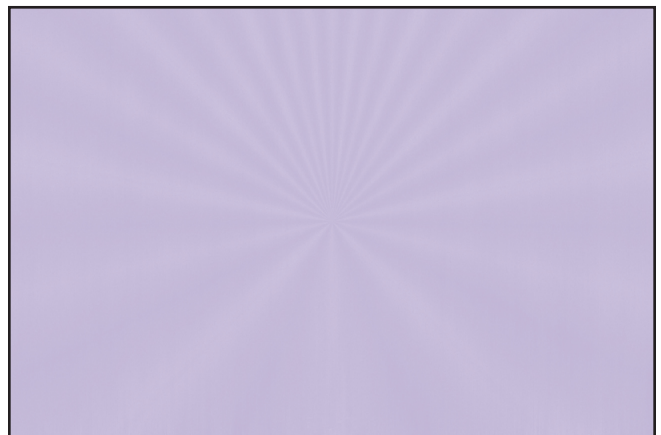

**04-GRADIENT CENTRE**

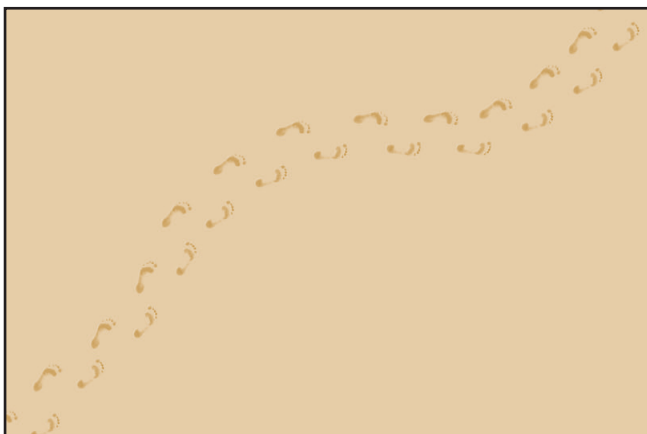

**04-FOOTPRINTS**

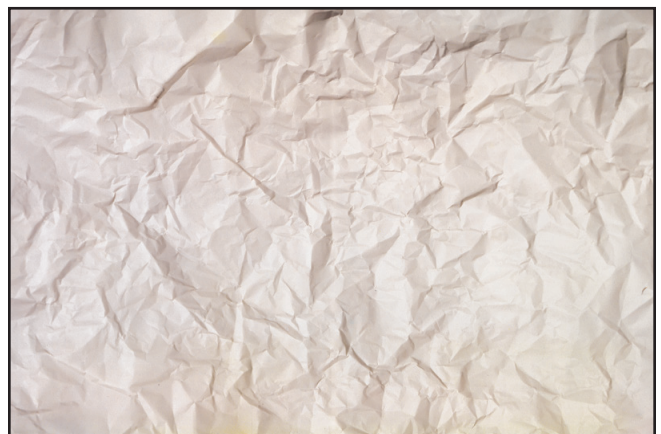

**04-PAPER BAG**

## ADDITIONAL STOCK COLOUR ENDSHEETS

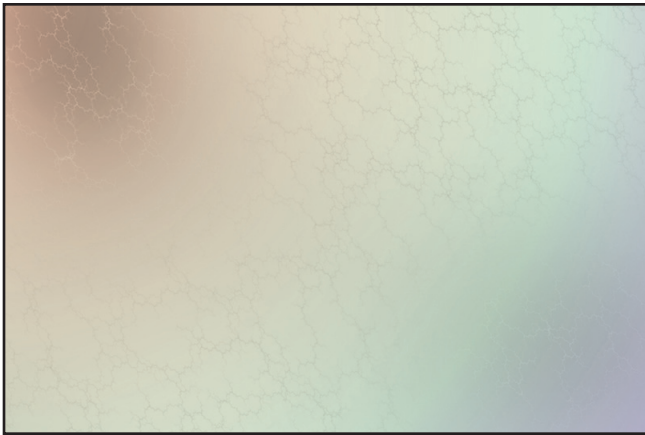

**04-GRADIENT**



**16-PROM**

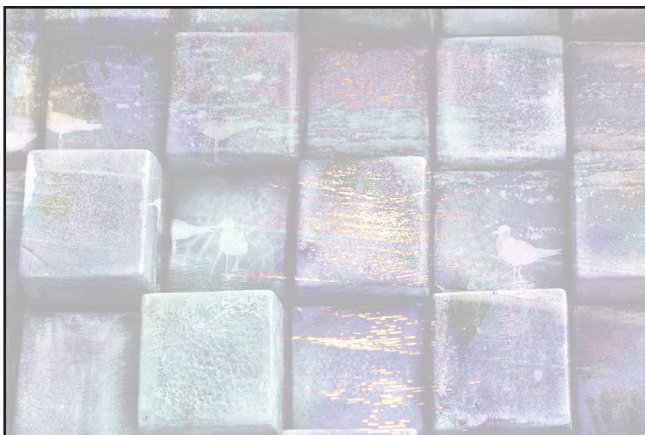

**16-BIRDIE BLOCKS**

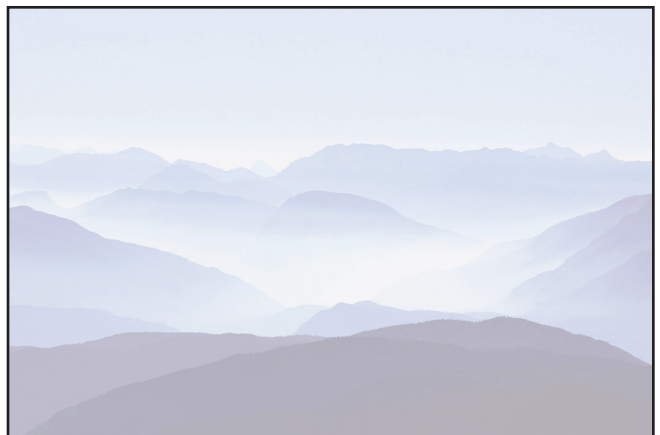

**16-BLUE RIDGE**



**16-BRICK WALL**



**16-CELEBRATION**



## ADDITIONAL STOCK COLOUR ENDSHEETS



**16-COOL BREEZE**



**16-CRAZY DAISY**



**16-GEARS**



**16-GIMME A SWING**



**16-PAISLEY**



**16-PICTURES OF THE PAST**

## ADDITIONAL STOCK COLOUR ENDSHEETS

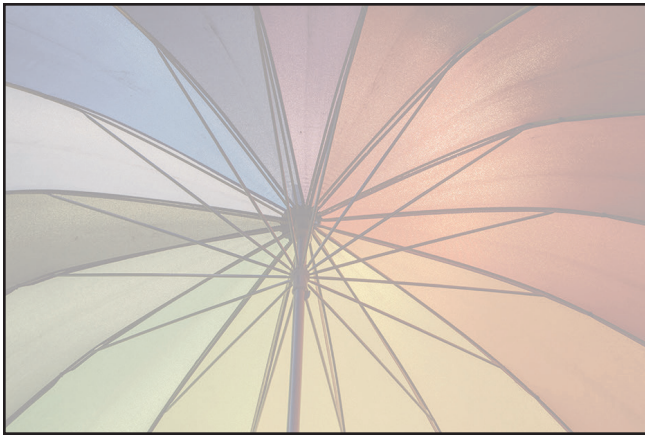

**16-RAINBOW UMBRELLA**

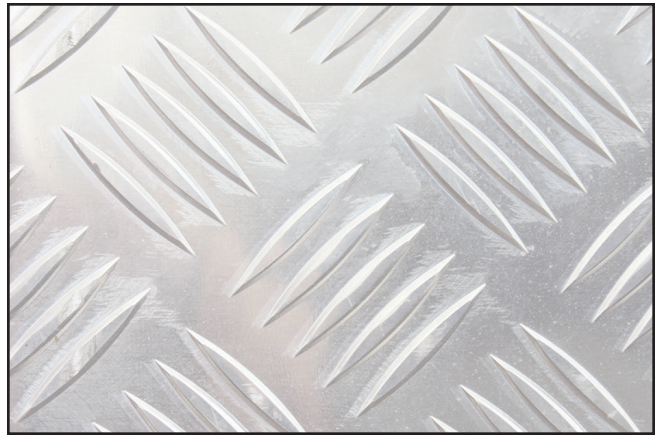

**16-REAL STEEL**



**16-SPLASH**

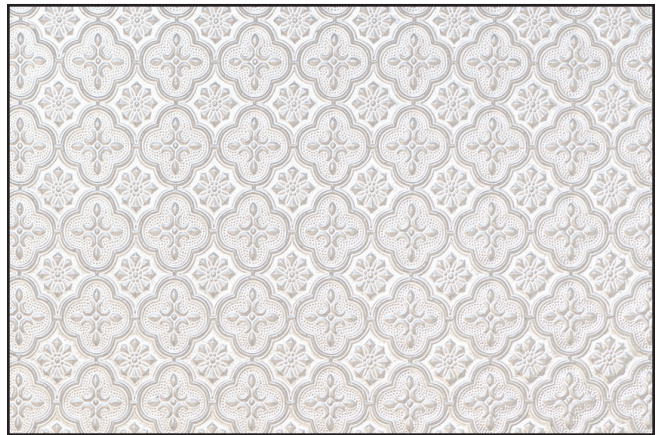

**16-TIN TILE**

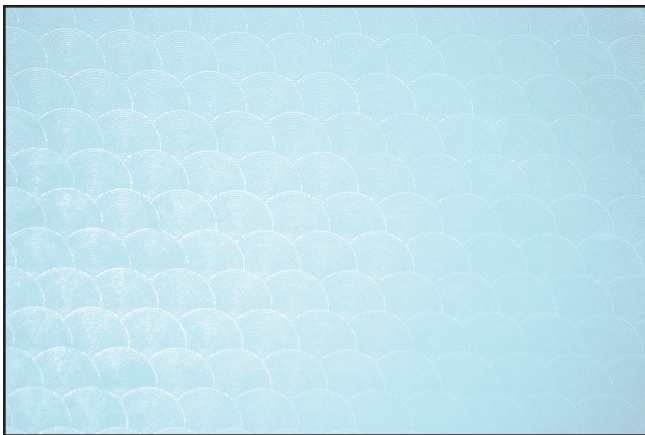

**16-TURQUOISE RINGS**



**16-TWO TONE STONE**

# STOCK EMBOSSED COVERS

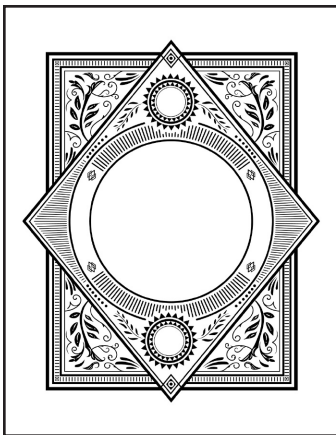

**STOCK EMOSS  
DIAMOND**

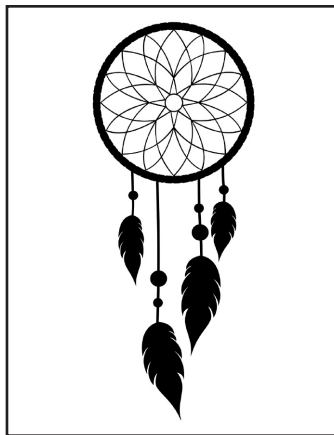

**STOCK EMOSS  
DREAM CATCHER**

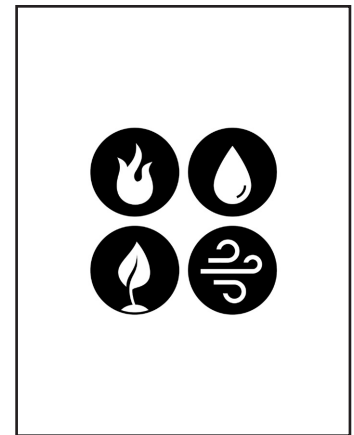

**STOCK EMOSS  
ELEMENTS**

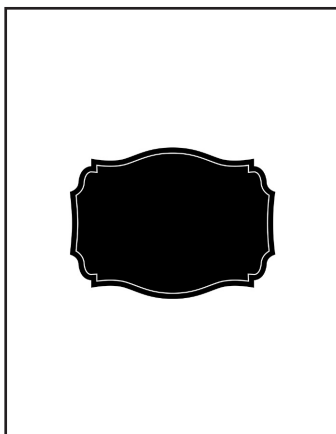

**STOCK EMOSS  
LABEL**

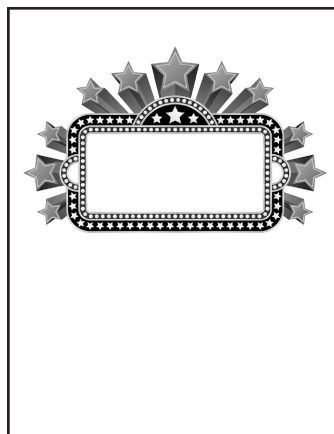

**STOCK EMOSS  
MARQUEE**



**STOCK EMOSS  
MEDAL**

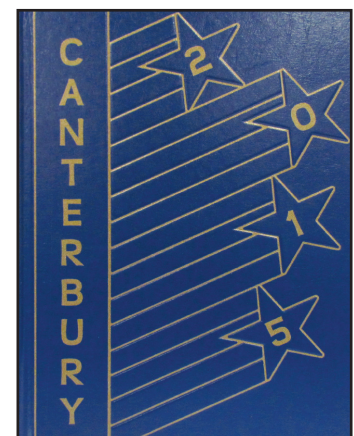

# STOCK EMBOSSED COVERS

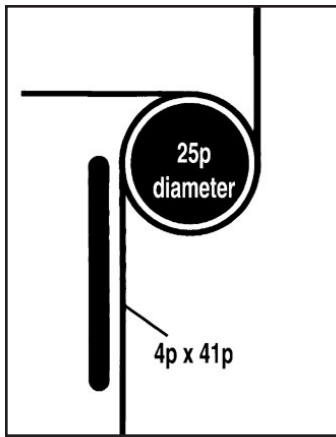

STOCK EMOSS A

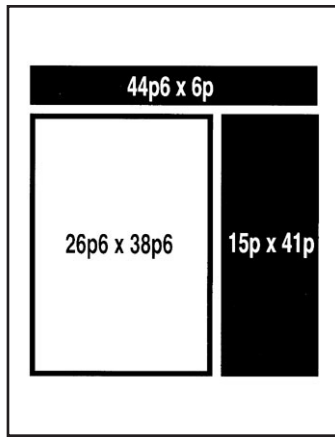

STOCK EMOSS E-1

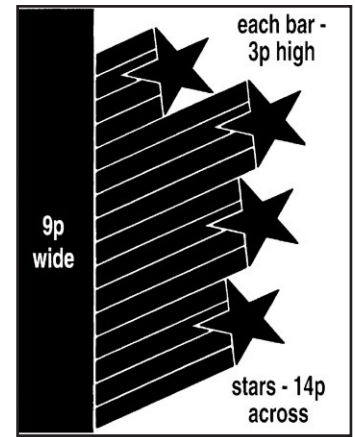

STOCK EMOSS J

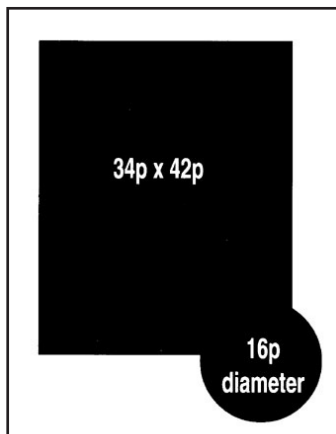

STOCK EMOSS K-2

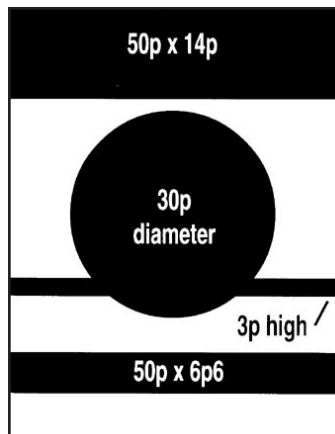

STOCK EMOSS L

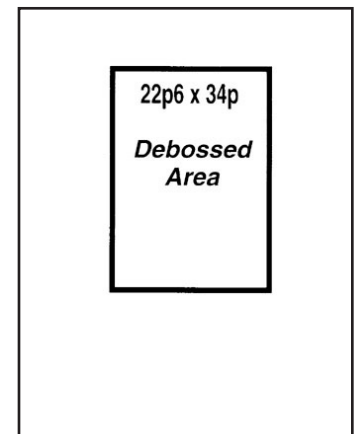

STOCK EMOSS O

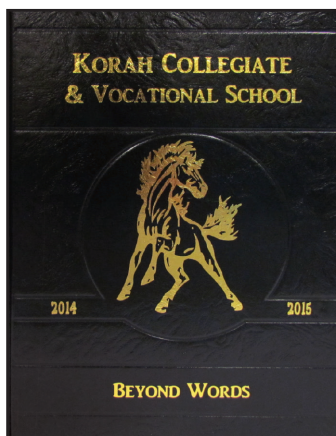

# STOCK EMBOSSED COVERS

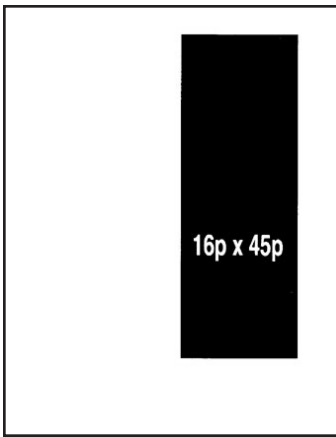

STOCK EMOSS Q

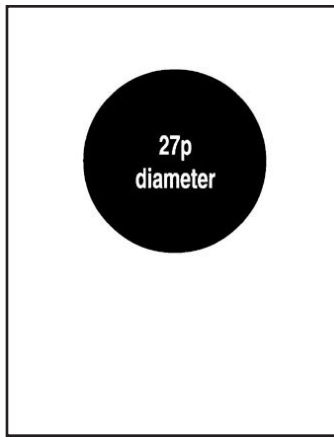

STOCK EMOSS R

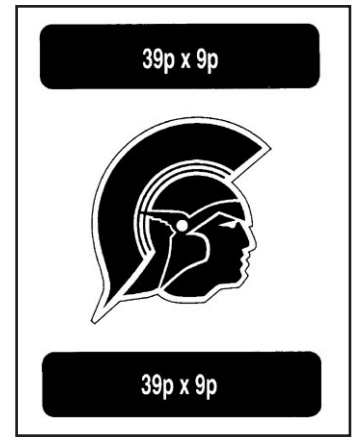

STOCK EMOSS W

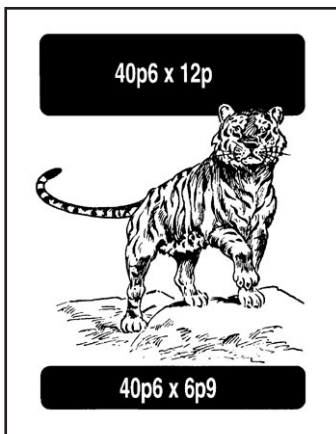

STOCK EMOSS X

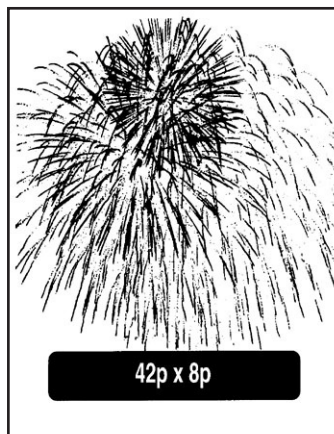

STOCK EMOSS  
FIREWORKS



STOCK EMOSS HOUR  
GLASS

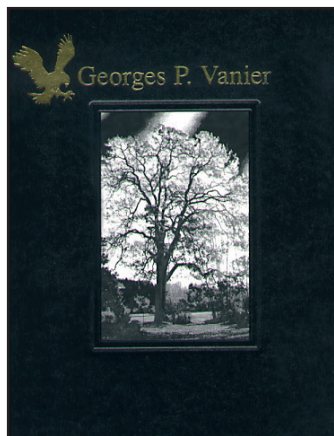
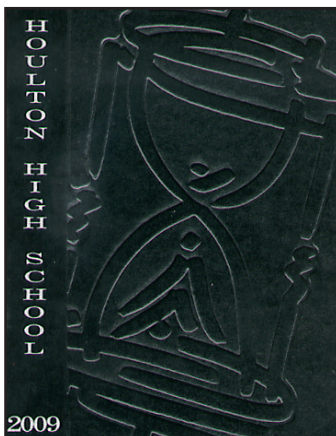

# STOCK METAL INLAY DESIGNS



16p x 16p

**STOCK METAL INLAY  
BEAR**

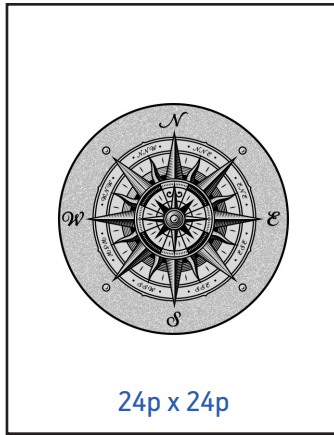

24p x 24p

**STOCK METAL INLAY  
COMPASS**

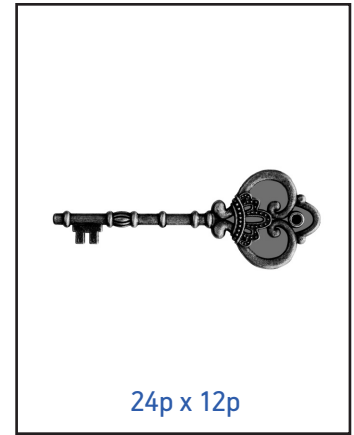

24p x 12p

**STOCK METAL INLAY  
KEY**

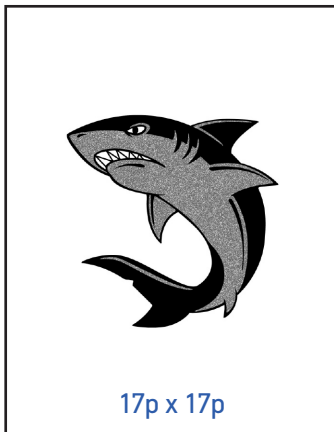

17p x 17p

**STOCK METAL INLAY  
SHARK**

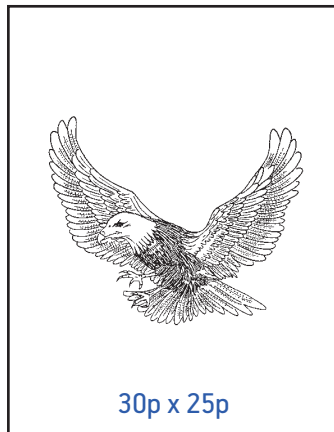

30p x 25p

**STOCK METAL INLAY  
EAGLE**



25p x 28p

**STOCK METAL INLAY  
TROJAN**



24p x 19p

**STOCK METAL INLAY  
BULLDOG**



29p x 35p

**STOCK METAL INLAY  
SHIP**



22p x 22p

**STOCK METAL INLAY  
EAGLE IN FLIGHT**

# STOCK METAL INLAY DESIGNS



17p x 20p

**STOCK METAL INLAY  
CREST**



13p x 15p

**STOCK METAL INLAY  
RAM**

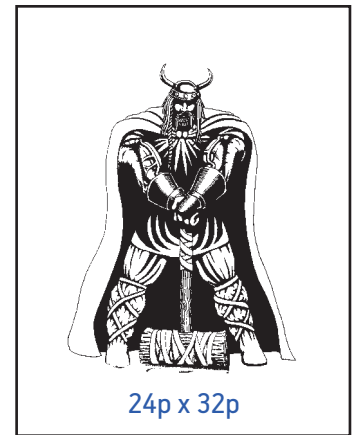

24p x 32p

**STOCK METAL INLAY  
VIKING**

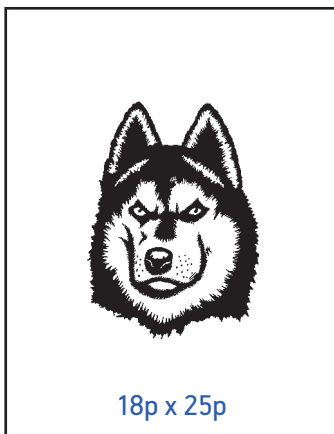

18p x 25p

**STOCK METAL INLAY  
HUSKY**

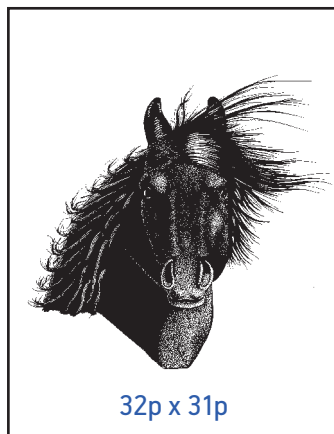

32p x 31p

**STOCK METAL INLAY  
MUSTANG**

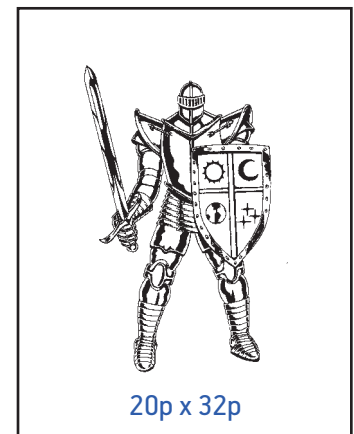

20p x 32p

**STOCK METAL INLAY  
KNIGHT**

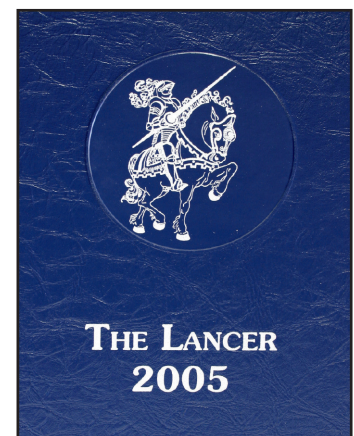
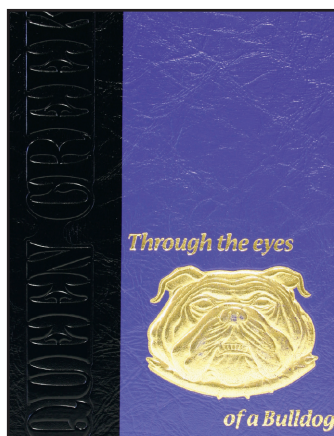
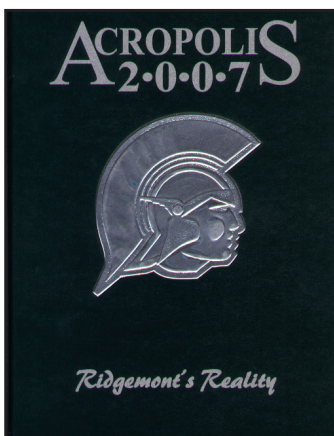

EST. 1907



**FRIESENS**

MEMORIES CRAFTED IN PRINT

— EMPLOYEE-OWNED —