

HMM-10T

MINI MOLDING MACHINE

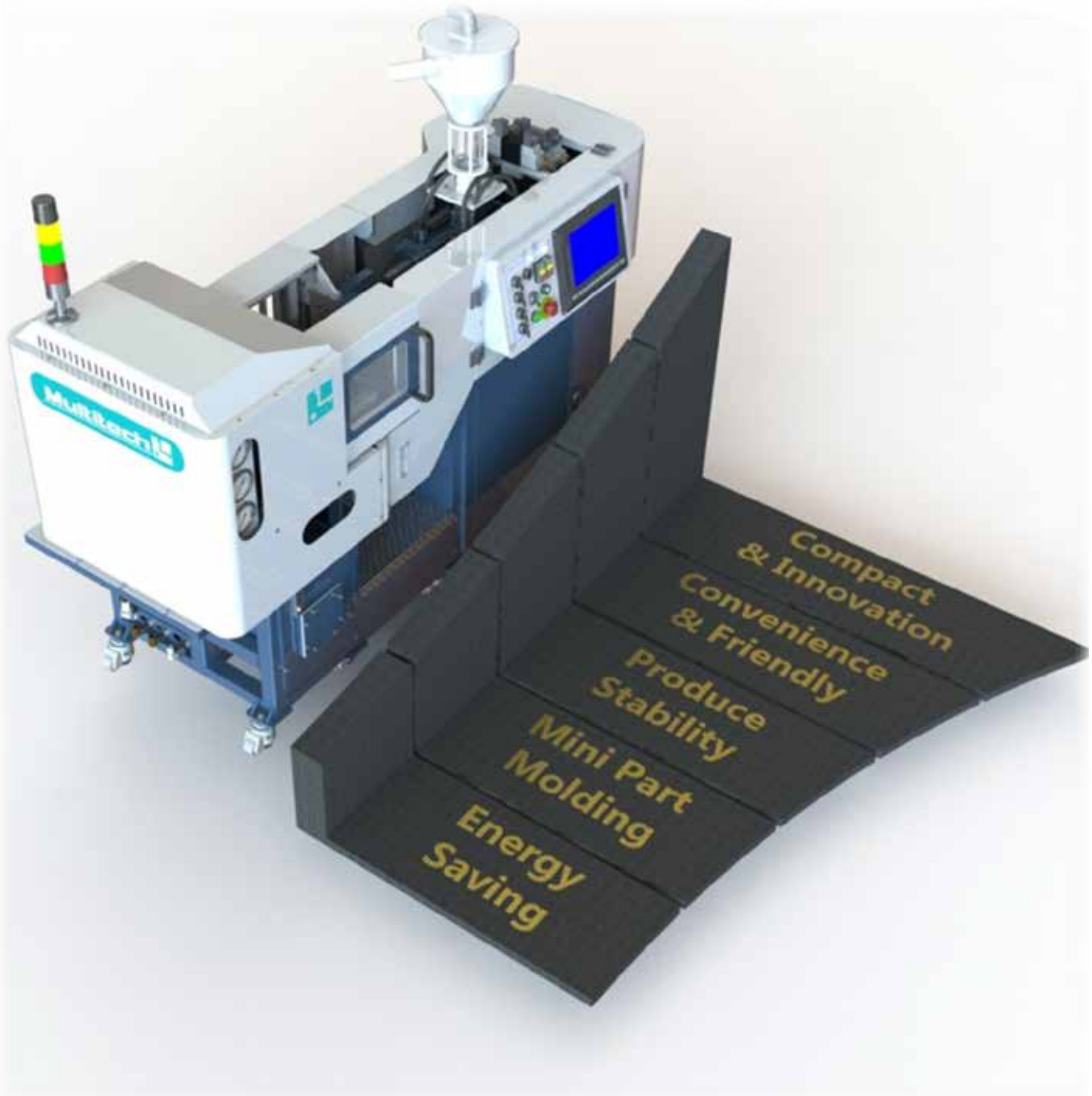

***SMALL TONNAGE WITH
GREAT STRENGTH***

ABSOLUTE Group of Companies

HEADQUARTERS

94 Gardner Street
Worcester, MA 01610
TEL: (508) 459-5372

Email:
sales@MultitechUSA.com

OHIO TECH CENTER

Service and Parts

12900 Plaza Drive
Parma, OH 44130
TEL: (216) 452-1000

parts@MultitechUSA.com
service@MultitechUSA.com

ILLINOIS TECH CENTER

280 Bellevue Lane
Batavia, IL 60510
TEL: (630) 761-9898

Multitech HK

Overseas sales office

Unit 74,4/F
Sino Industrial Plaza
9 Kai Cheung Road
Kowloon Bay, HK
Tel: [852] 2796 9622
Fax: [852] 2796 9626
E-mail:
multitech@multitech-imm.com

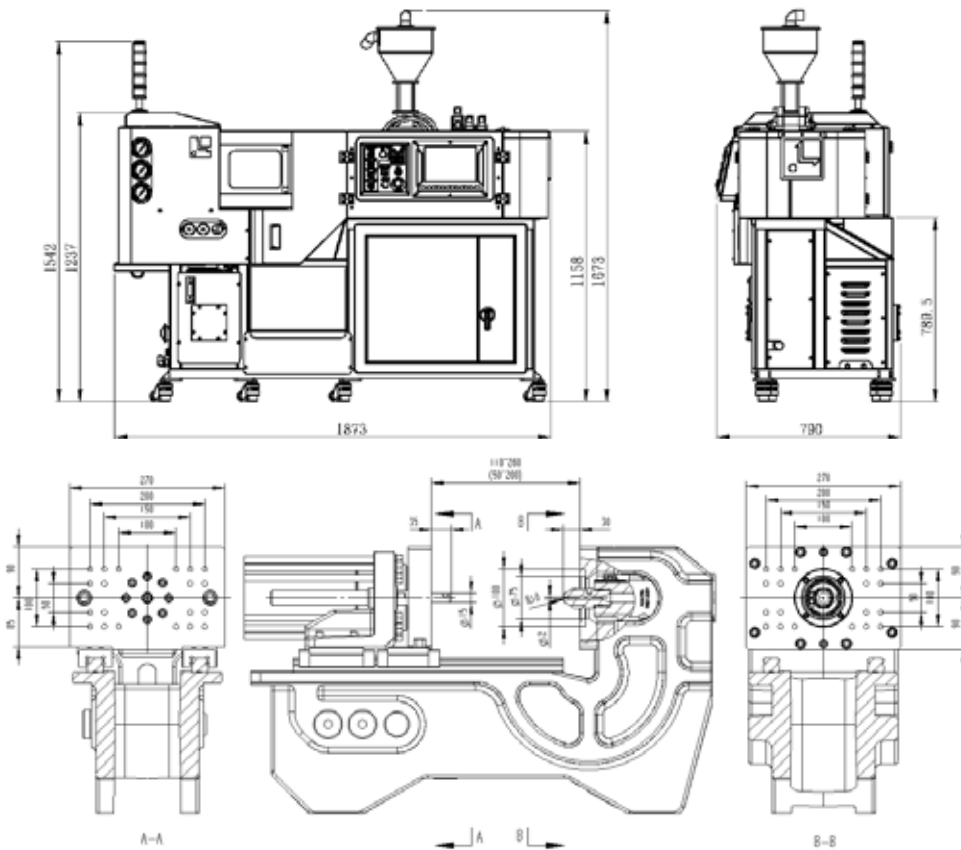

| | Performance Item | unit | Injection Screw Diameter | | |
|----------------|-------------------------------|----------------------|--------------------------|----------|-------|
| | | | 14 | 16 | 18 |
| Injection Unit | Theoretical Injection Volume | cm ³ | 10.8 | 14.1 | 17.8 |
| | Injection Weight (PS), max | g | 9.9 | 12.9 | 16.4 |
| | Injection Flow, max | cm ³ /sec | 21.6 | 28.1 | 35.6 |
| | Injection Pressure, max | MPa | 253.5 | 194.1 | 153.3 |
| | Injection Stroke | mm | | 70.0 | |
| | Injection Speed, max | mm/sec | | 140.0 | |
| | Screw Rotation Speed, max | rpm | | 300.0 | |
| | Plasticity Capacity (PS) | g/sec | 1.9 | 2.6 | 3.4 |
| | Heater Power | KW | | 1.9 | |
| | Number of Heating Zones | N/A | | 3.0 | |
| Clamping Unit | Max. Clamping Force | KN | | 98.6 | |
| | Max. Mold Opening Force | KN | | 20.6 | |
| | Min. Mold Thickness | mm | | 50(110) | |
| | Max. Opening Daylight | mm | | 200(260) | |
| | Max. Mold Width | mm | | 270.0 | |
| | Max. Mold Length | mm | | 180.0 | |
| | Min. Mold Width | mm | | 90.0 | |
| | Min. Mold Length | mm | | 90.0 | |
| | Ejector Force | KN | | 4.3 | |
| | Ejector Stroke | mm | | 35.0 | |
| Utility Unit | Total Electric Power Capacity | KW | | 6.2 | |
| | 1.Hydraulic Drive Motor Power | KW | | 3.5 | |
| | 2.Barrel Heater power | KW | | 1.9 | |
| | 3.Controller Power | KW | | 0.8 | |
| | Cooling Water | LPM | | 6.0 | |
| | Hydraulic Oil Capacity | L | | 40.0 | |
| Machine Weight | kg | | 750 | | |