

# INSYS Smart Device Monitoring App

Collecting a Modbus value  
and uploading it to the  
Telekom Cloud der Dinge

## Introduction

---

Copyright © 2024 INSYS icom GmbH

Any duplication of this publication is prohibited. All rights on this publication and the devices are with INSYS icom GmbH Regensburg.

### Trademarks

The use of a trademark not shown below is not an indication that it is freely available for use.

MNP is a registered trademark of Microcom Inc.

IBM PC, AT, XT are registered trademarks of International Business Machine Corporation.

Windows™ is a registered trademark of Microsoft Corporation.

Linux is a registered trademark of Linus Torvalds.

INSYS® is a registered trademark of INSYS icom GmbH.

Debian is a registered trademark of Software in the Public Interest, Inc.

The principles of this publication may be transferred to similar combinations. INSYS icom GmbH does not assume liability or provide support in this case. Moreover, it cannot be excluded that other effects or results than described here are produced, if other, similar components are combined and used.

INSYS icom GmbH is not liable for possible damages.

### Publisher

INSYS icom GmbH  
Hermann-Köhl-Str. 22  
D-93049 Regensburg  
Germany

Phone +49 941 58692 0  
Fax +49 941 58692 45  
E-mail [info@insys-icom.com](mailto:info@insys-icom.com)  
URL <http://www.insys-icom.com>

Print 24. Jan. 2024  
Item No. -  
Version 1.1  
Language EN

# 1 Introduction

## General

---

The present publication refers to a combination of selected hardware and software components of INSYS icom GmbH as well as other manufacturers. All components have been combined with the target to realize certain results and effects for certain applications in the field of professional data transfer.

The exact descriptions of all used components, to which this publication refers, are described in the tables *Hardware*, *Accessories* and *Software* at the end of this publication.

The symbols and formatings used in this publication are explained in the correspondent section of the device manual.

Some configurations or preparations, which are precondition in this publication, are described in other publications. Therefore, always refer to the related device manuals. INSYS Smart Devices with web interface provide you with helpful information about the configuration possibilities, if you click on "display help text" in the header.

### Target of this Publication

An exemplary configuration for a typical fault monitor application is presented here. If your application has similar requirements, you may modify the configuration on the basis of this Configuration Guide. An adaptation to another service provider as the one described here as an example is also possible.

A temperature sensor is connected to the fault monitor IMON-G200 via a Modbus converter (Application Connector). The temperatures measured by the temperature sensor will be sent regularly to the Telekom Cloud der Dinge (Cloud of Things) that collects the data and visualises them clearly in a web interface.

This allows to record the temperature over the time in a cold room to verify the integrity of the cold chain. The services, names, values and addresses specified in this Configuration Guide are exemplary and must be adjusted to your application accordingly.

The following describes how to configure the Monitoring App of an INSYS IMON fault monitor such that it fulfils above described task. It is prerequisite here that the fault monitor is ready for operation, i.e. a SIM card is inserted and it is configured accordingly. An access to the Telekom Cloud der Dinge is also presumed. If you don't have an access, you can subscribe by phone under +49 800 330 5400.

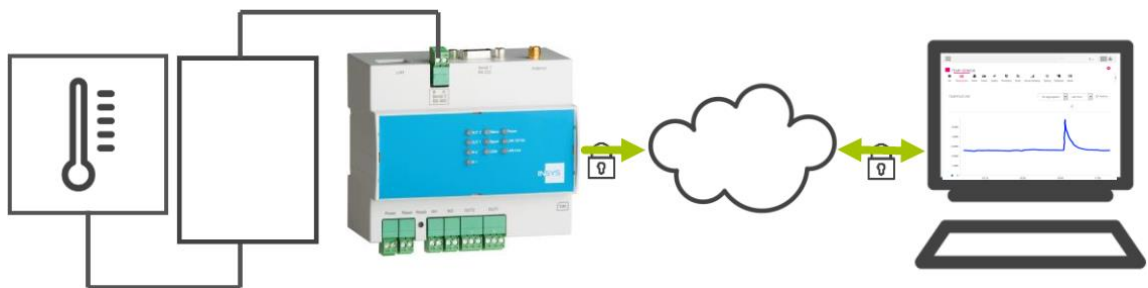

Figure 1: Uploading and visualising Modbus values – overview

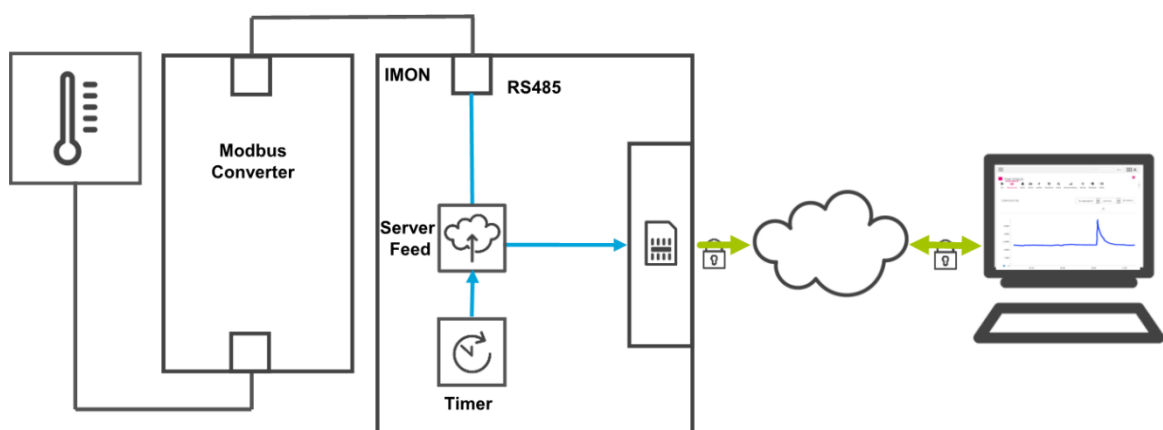

Figure 2: Uploading and visualising Modbus values – simplified diagram

## 2 Summary

### Fault monitor configuration

---

How to configure an INSYS fault monitor for monitoring a Modbus register and triggering a message dispatch. You will find detailed step by step instructions in the following section.

- Add device "Modbus" with Modbus type and RTU connection
- Add element "Sensor\_signal" as Modbus register
- Add element "Timer" as recurrent timer with 15 minutes
- Add recipient "Telekom" as Cumulocity Cloud with the respective access data and the device name
- Add monitoring "Timer\_expired" (Timer expired)
- Add action "Server\_Feed" as server feed to "Telekom" with the respective parameters
- Add assignment "Temp\_expired" to "Server\_Feed"

# 3 Configuration

## Provisions

---

It is recommended to commission the router as suggested in the Quick Installation Guide. Different settings of the router may result in necessary adjustments of the settings described in the following. Please prepare the following items before starting the configuration of the application:

- **Connection to the router**

- You have access to the Monitoring App of the router via your web browser.

- **Configurations in the router**

- The router is logged in to the cellular network (configuration via startup wizard or in "GSM / GPRS" or "UMTS" menu).

## Monitoring App Configuration

---

A functional Monitoring App requires to add the individual devices, elements, logic operations, recipients, monitorings and actions as well as the assignment of actions to monitorings.

Perform the following steps for this:

- **Adding devices**
- **Adding elements**
- **Adding recipients**
- **Adding monitorings**
- **Adding actions**
- **Adding assignments**

■ Adding devices

How to add the necessary devices for the Monitoring App. It is necessary to add the connected Modbus converter as a device for this application.

1. Select in the menu the page → Setup application → Devices
2. Select the Add device button
  - ✓ The "Add device" page appears.
3. Enter "Modbus" as name and select "Modbus" as type and "RTU" as connection
4. Select the serial interface "Serial 2" and enter the remaining parameters according to your Modbus converter

**Gerät hinzufügen**

5. Click on OK
  - ✓ You have added the devices that are necessary for the application with this.

## Configuration

### ■ Adding elements

How to add the necessary elements for the monitoring application. It is necessary to add the respective Modbus register and a timer, which triggers a regular transmission of the values, as elements for this application.

1. Select in the menu the page → Setup application → Elements
2. Select the **Add Element** button
  - ✓ The "Add element" page appears.
3. Enter "Sensor\_signal" as name and select "Modbus", "Modbus" and "Holding register" under Device
4. Enter the respective Modbus register (here "0")



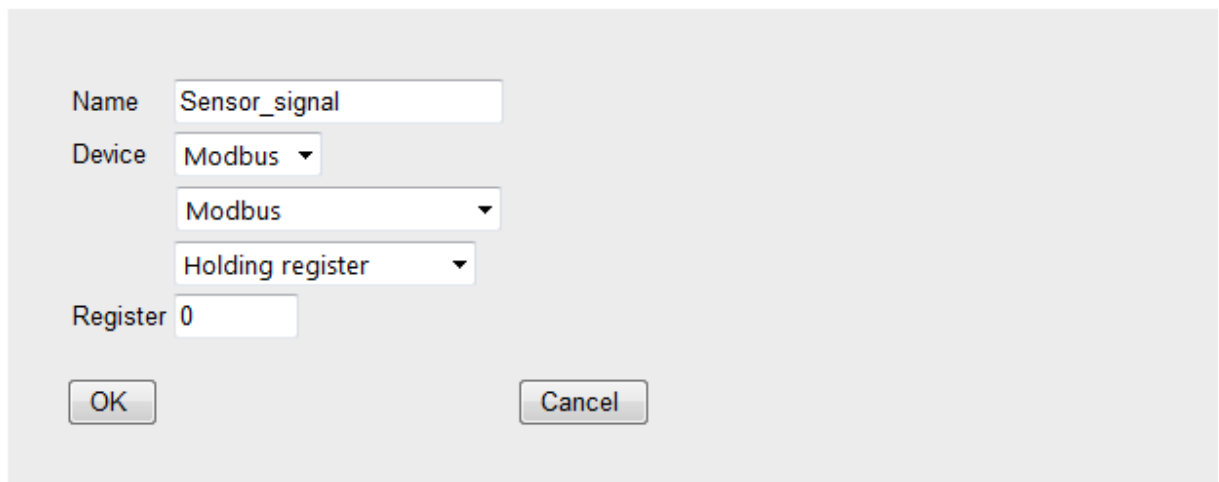

### Add element



5. Click on **OK**
6. Select the **Add element** button again and add the element "Timer" (recurrent timer with 15 minutes)
  - ✓ The elements appear in the respective list one after another.

### Elements

**Add element**

Active		Name	Device / Source
<input checked="" type="checkbox"/>	 	Sensor_signal (Modbus )	Modbus Holding register 0
<input checked="" type="checkbox"/>	 	Timer (Timer )	recurrent timer 00:15:00

- ✓ You have added the elements that are necessary for the monitoring application with this.



■ Adding recipients

How to add the necessary recipients for the Monitoring App. It is necessary to add the Telekom Cloud der Dinge access for this application. You'll get the access data necessary for this from your administrator or when subscribing to the service.

1. Select in the menu the page → Setup application → Recipients
2. Select the **Add recipient** button
  - ✓ The "Add recipient" page appears.
3. Enter "Telekom" as name
4. Select the recipient type "Cloud of Things"
5. Select the protocol "https"
  - ⓘ *Even if your provider offers an unencrypted connection, it is recommended to use the protected https protocol.*
6. Enter the URL of your Telekom Cloud der Dinge account as Server URL
7. Enter the user name of your account as User and the associated Password
8. Enter a descriptive name for the monitored device under "Device name".
9. Don't enter a Device ID to obtain the device ID from the service automatically



**Empfänger**

The screenshot shows a configuration window titled "Empfänger". It contains several input fields and a dropdown menu. The "Name" field is filled with "Telekom". The "Empfängertyp" dropdown is set to "Cloud der Dinge". Under "Protokoll", the "https" radio button is selected. The "Server-URL" field contains "server\_address.com". The "Benutzer" field contains "admin". The "Password" field contains "xxxxxxxxxx". The "Gerätename" field contains "Temp. Sensor". The "Geräte-ID" field contains "Geräte-ID automatisch anfordern". At the bottom left is an "OK" button and at the bottom right is an "Abbrechen" button.

10. Click on **OK**
  - ✓ The entered recipient appears in the list under "Recipients".

### Empfänger

Empfänger hinzufügen

aktiv	Name	Telefon
<input checked="" type="checkbox"/>	  Telekom	Cumulocity-Cloud insys-tec.m2m-devicecloud.com admin Temp. Sensor 55613800

- i** *In order to test the connection to the Telekom Cloud der Dinge, the page can be reloaded after some time. If the device ID received from the Telekom Cloud der Dinge (55613800 in the example) is displayed, connection establishment was successful. If this is not displayed, access data and Internet connection of the router should be checked.*
- ✓ You have added the recipients that are necessary for the application with this.

## ■ Adding monitoring operations

How to add the monitoring operations for the Monitoring App. It is necessary to monitor the expiry of the timer for this application.

1. Select in the menu the page → Monitoring
2. Select the **Add monitoring** button
  - ✓ The "Add monitoring" page appears.
3. Enter "redTimer\_expi" as name and select "Element", "Timer" and "finished" under Source

### Überwachung hinzufügen

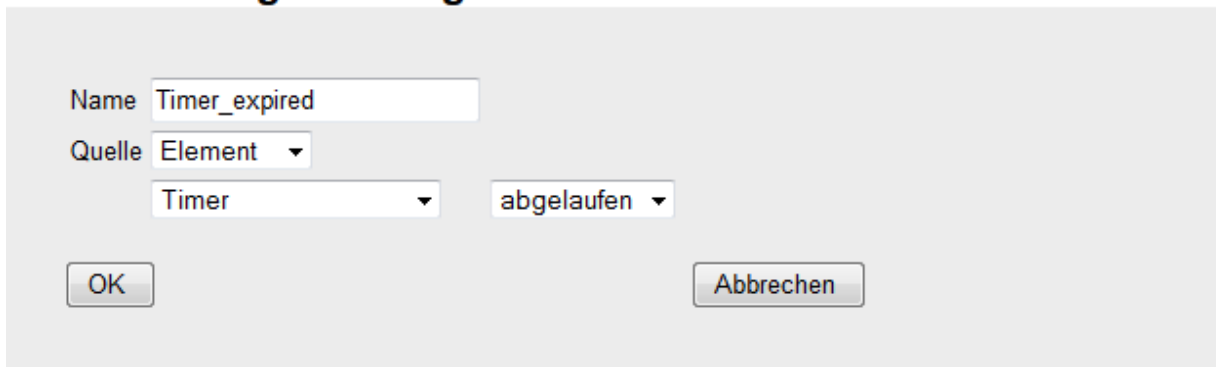

The screenshot shows a configuration dialog box titled "Überwachung hinzufügen". It contains the following fields and controls:

- Name:** A text input field containing "Timer\_expired".
- Quelle:** A dropdown menu currently showing "Element".
- Timer:** A dropdown menu currently showing "Timer".
- abgelaufen:** A dropdown menu currently showing "abgelaufen".
- Buttons:** "OK" and "Abbrechen" (Cancel) buttons are located at the bottom of the dialog.

4. Click on **OK**
  - ✓ You have added the monitoring operations that are necessary for the application with this.

## Configuration

### ■ Adding actions

How to add the actions for the Monitoring App. It is necessary to execute a server feed for this application.

1. Select in the menu the page → Actions → Definitions
2. Select the **Add action** button
  - ✓ The "Add action" page appears.
3. Enter "Server\_Feed" as name and select "Server feed" as Target
4. Select the previously added recipient "Telekom" as recipient
5. Select the Message type "Measurements"
6. Enter "Temperature" as Chart name
7. Enter "Temp" as Type
8. Enter "° C" as Unit
- i** *Chart name and unit appear in the chart. The type is an attribute that can be used by downstream applications to distinguish the value.*
9. Highlight "Sensor\_signal" under Available elements and select the **>>** button

### Aktion hinzufügen

Name: Server\_Feed

Ziel: Server-Feed

Empfänger: Telekom

Nachrichtentyp: Messwerte

Chart-Name: Temperature

Typ: Temp

Einheit: ° C

verfügbare Elemente

ausgewählte Elemente: Sensor\_signal

Buttons: >>, <<, OK, Abbrechen

10. Click on **OK**
  - ✓ You have added the actions that are necessary for the application with this.

### ■ Adding assignments

How to add the assignments for the Monitoring App. It is necessary to assign the respective actions to the monitorings for this application.

1. Select in the menu the page → Actions → Assignments
2. Select the **Add assignment** button
  - ✓ The "Add assignment" page appears.
3. Select "Timer\_expired" as Monitoring and "Server\_Feed" as Action

### Zuordnung hinzufügen



Überwachung                      Aktion

Timer\_expired                      -> Server\_Feed

OK    Abbrechen

4. Click on **OK**
  - ✓ You have added the assignments that are necessary for the application with this.

## 4 Test

### Testing the application

---

The Monitoring App is active directly after configuration. You can verify the correct function directly by opening your Telekom Cloud der Dinge account and checking whether the values are uploaded and visualised.

After login, you'll get to a selection page where you select "Browsing Devices". Then, you'll get to an overview of all devices added there. Select the respective device there (in this example "Temp. Sensor").

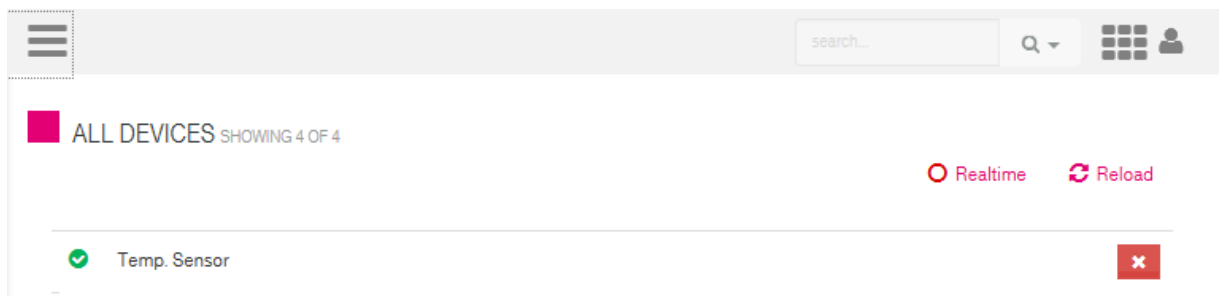

Select the "Measurements" menu there to show the created chart. The temperature of the connected sensor should be displayed here over the time.

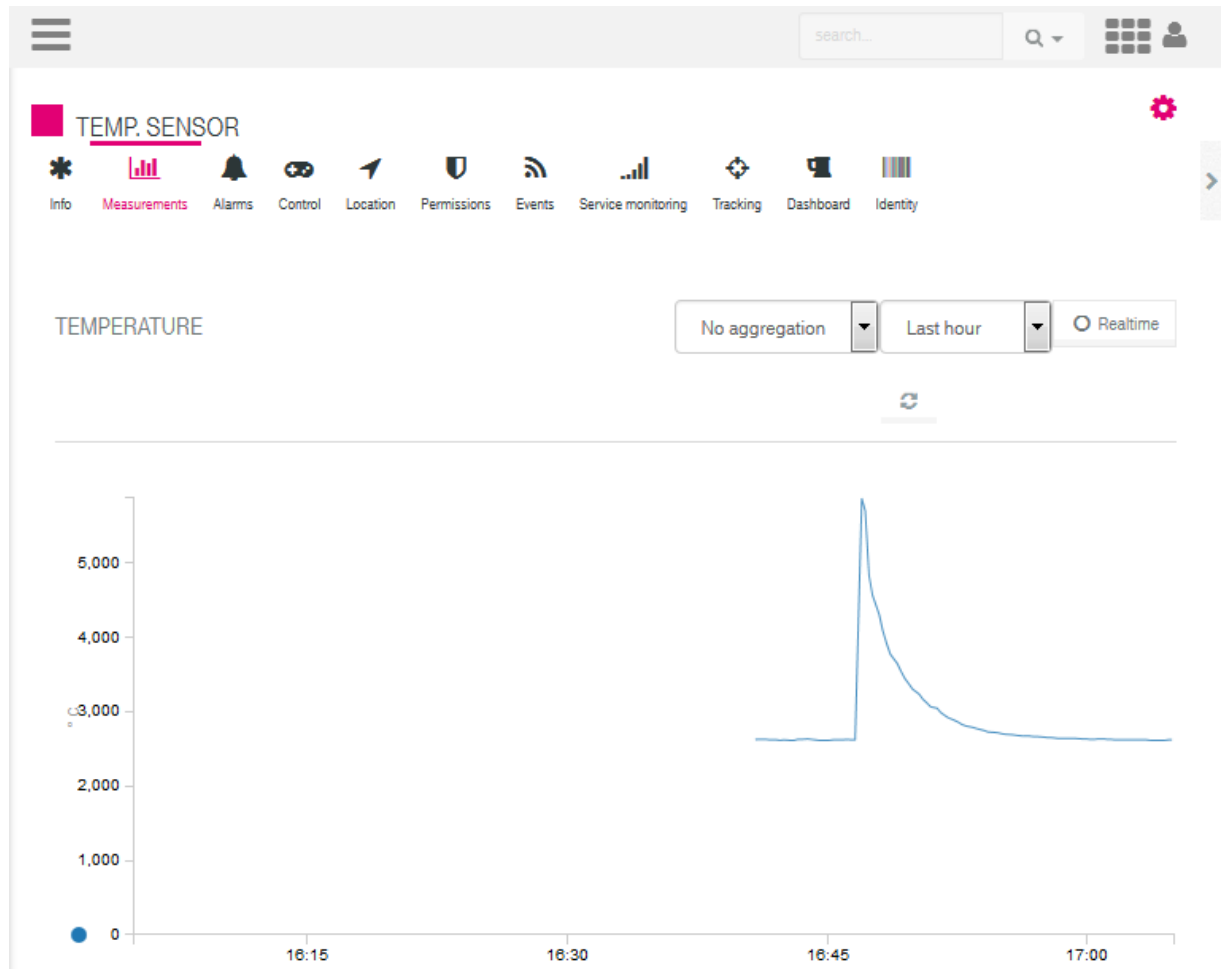

## 5 Used Components

Please observe: The power supply units required to operate devices are not listed here in detail. Take care for a provision at the site, if they are not part of the scope of delivery.

### Hardware

Designation	Manufacturer	Type	Version
Fault Monitors	INSYS	IMON-G200	Firmware 2.12.5 Monitoring 2.2.0
Modbus converter	CEL-MAR	ADA-401WP	-
Temperature sensor	Conrad	No. 19 82 84	-

Table 1: Used hardware

### Software

Designation	Manufacturer	Type	Version
Operating system	Microsoft	Windows 7	Ultimate SP1
Browser	Mozilla	Firefox	39

Table 2: Used software









## **Germany**

INSYS icom GmbH  
Hermann-Köhl-Str. 22  
93049 Regensburg  
Germany

Phone +49 941 58692 0  
Fax +49 941 58692 45

E-mail [info@insys-icom.com](mailto:info@insys-icom.com)  
URL [www.insys-icom.com](http://www.insys-icom.com)

## **Czech Republic**

INSYS icom CZ, s.r.o.  
Slovanská alej 1993 / 28a  
326 00 Plzeň-Východní Předměstí  
Czech Republic

Phone +420 377 429 952  
Fax +420 377 429 952  
Mobile +420 777 651 188

E-mail [info@insys-icom.cz](mailto:info@insys-icom.cz)  
URL [www.insys-icom.cz](http://www.insys-icom.cz)