



Bector Automation RML Ltd

Kuruli, Tal-Khed
 410501 Pune
 Phone. +91 20 30781208

Company / customer	Strides Pharma Ltd.			
Drawing Number	16049-0301			
Project description	p780 Sachet Cartoner			
Commission	Bector Automation RML			
Manufacturer (company)	Bector Automation RML Ltd			
Project name	16049 Sachet Cartoner_V1.1			
Make	RML Engineering Ltd			
Type	Electrical Control System			
Place of installation	Bengaluru			
Responsible for project	Sahana I H			
Part feature				
Edit date	8/29/2022	by (short name) EPLAN	Number of pages	103

Table of contents

rmlA_TableofContents_004

Assignment	Page	Page description	Page type	Date	Edited by
=p780 +00	Table of contents				
	001	Title page / cover sheet	Title page / cover sheet	10/6/2021	EPLAN
	002	Table of contents : =p780+00/001 - =p780+CP0301/210	Table of contents	7/28/2022	EPLAN
	002.a	Table of contents : =p780+CP0301/211 - =p780+CP0301/253	Table of contents	7/28/2022	EPLAN
	002.b	Table of contents : =p780+CP0301/254 - =p780+XC4011/004	Table of contents	7/28/2022	EPLAN
	002.c	Table of contents : =p780+XC4011/005 - =p780+RO4131/006	Table of contents	7/28/2022	EPLAN
=p780 +CP0301	Main Control Cabinet				
	001	Title page / cover sheet	Title page / cover sheet	10/6/2021	EPLAN
	003	Technical Information	Overview	7/27/2022	EPLAN
	004	Panel Label	Graphic	10/31/2019	pmelton
	005	Control Panel Duct Plan	Panel layout	7/4/2022	EPLAN
	006	Control Panel Layout	Panel layout	7/28/2022	EPLAN
	010	Network: Robot WAN Switch	Schematic multi-line	7/28/2022	EPLAN
	030	Network: Stratix Network Switch	Schematic multi-line	7/28/2022	EPLAN
	100	Power Distribution: 400V Supply	Schematic multi-line	7/28/2022	EPLAN
	101	Power Distribution: 400V & GPO	Schematic multi-line	7/27/2022	EPLAN
	102	Power Distribution: 24VDC Power Supply	Schematic multi-line	7/27/2022	EPLAN
	103	Power Distribution: 24VDC Distibution Terminals	Schematic multi-line	7/28/2022	EPLAN
	108	Power Distribution: MO1701 Main Drive Servo	Schematic multi-line	7/28/2022	EPLAN
	109	Power Distribution: MO2701 MG Pick and Place Servo Motor	Schematic multi-line	7/27/2022	EPLAN
	110	Power Distribution: MO2301 Infeed Conveyor Motor	Schematic multi-line	7/28/2022	EPLAN
	120	Power Distribution: MO3101 Outfeed Conveyor Motor	Schematic multi-line	7/27/2022	EPLAN
	130	Power Distribution: Safety Contactors	Schematic multi-line	7/27/2022	EPLAN
	140	Power Distribution: MO3102 Conveyor Motor 2	Schematic multi-line	7/6/2022	EPLAN
	141	Power Distribution: MO3103 Conveyor Motor 3	Schematic multi-line	7/6/2022	EPLAN
	143	Power Distribution: MO3104 Conveyor Motor 4	Schematic multi-line	7/6/2022	EPLAN
	150	Control System: Misc I/O	Schematic multi-line	7/6/2022	EPLAN
151	Control System: Power Distribution	Schematic multi-line	7/27/2022	EPLAN	
210	Control System: XC0301 - PLC Overview	Schematic multi-line	7/28/2022	EPLAN	

Table of contents

rmlA_TableofContents_004

Assignment	Page	Page description	Page type	Date	Edited by
=p780 +CP0301	Main Control Cabinet				
	211	Control System: XC0301 Connections	Schematic multi-line	7/6/2022	EPLAN
	213	Control System: XC0302 PLC Power Expansion Cards	Schematic multi-line	7/6/2022	EPLAN
	214	Control System: XC0302:Slot 1 Safety Inputs	Schematic multi-line	7/6/2022	EPLAN
	215	Control System: XC0302:Slot 1 Safety Inputs	Schematic multi-line	7/6/2022	EPLAN
	216	Control System: XC0302:Slot 2 Safety Inputs	Schematic multi-line	7/5/2022	EPLAN
	217	Control System: XC0302:Slot 2 Safety Inputs	Schematic multi-line	6/28/2022	EPLAN
	218	Control System: XC0302:Slot 3 Safety Inputs	Schematic multi-line	6/28/2022	EPLAN
	219	Control System: XC0302:Slot 3 Safety Inputs	Schematic multi-line	6/28/2022	EPLAN
	220	Control System: XC0302:Slot 4 Safety Inputs	Schematic multi-line	7/5/2022	EPLAN
	221	Control System: XC0302:Slot 4 Safety Inputs	Schematic multi-line	6/28/2022	EPLAN
	222	Control System: XC0302:Slot 5 Safety Inputs	Schematic multi-line	7/28/2022	EPLAN
	223	Control System: XC0302:Slot 5 Safety Inputs	Schematic multi-line	7/28/2022	EPLAN
	224	Control System: XC0302:Slot 6 Safety Inputs	Schematic multi-line	7/5/2022	EPLAN
	225	Control System: XC0302:Slot 6 Safety Inputs	Schematic multi-line	7/5/2022	EPLAN
	226	Control System: XC0302:Slot 7 Safety Inputs	Schematic multi-line	7/5/2022	EPLAN
	227	Control System: XC0302:Slot 7 Safety Inputs	Schematic multi-line	7/5/2022	EPLAN
	228	Control System: XC0302:Slot 8 Safety Inputs	Schematic multi-line	7/28/2022	EPLAN
	229	Control System: XC0302:Slot 8 Safety Inputs	Schematic multi-line	7/5/2022	EPLAN
	231	Control System: XC0302:Slot 9 Safety Outputs	Schematic multi-line	7/5/2022	EPLAN
	232	Control System: XC0302:Slot 9 Safety Outputs	Schematic multi-line	7/28/2022	EPLAN
	240	Control System: XC0302:Slot 10 Outputs	Schematic multi-line	7/28/2022	EPLAN
	241	Control System: XC0302:Slot 11 Outputs	Schematic multi-line	7/28/2022	EPLAN
	242	Control System: XC0302:Slot 12 Outputs	Schematic multi-line	7/28/2022	EPLAN
	243	Control System: XC0302:Slot 13 Outputs	Schematic multi-line	7/28/2022	EPLAN
244	Control System: XC0302:Slot 14 Outputs	Schematic multi-line	7/28/2022	EPLAN	
251	Control System: XC0302:Slot 15 Inputs	Schematic multi-line	7/6/2022	EPLAN	
252	Control System: XC0302:Slot 16 Inputs	Schematic multi-line	7/28/2022	EPLAN	
253	Control System: XC0302:Slot 17 Inputs	Schematic multi-line	7/28/2022	EPLAN	

Table of contents

rmlA_TableofContents_004

Assignment	Page	Page description	Page type	Date	Edited by
=p780 +CP0301 Main Control Cabinet					
	254	Control System: XC0302:Slot 18 Inputs	Schematic multi-line	6/30/2022	EPLAN
	255	Control System: XC0302:Slot 19 Inputs	Schematic multi-line	7/28/2022	EPLAN
	256	Control System: XC0302:Slot 20 Inputs	Schematic multi-line	7/28/2022	EPLAN
	257	Control System: XC0302:Slot 21 Inputs	Schematic multi-line	7/28/2022	EPLAN
	258	Control System: XC0302:Slot 22 Outputs	Schematic multi-line	7/28/2022	EPLAN
	259	Control System: XC0302:Slot 23 Outputs	Schematic multi-line	7/28/2022	EPLAN
	260	Control System: XC0302:Slot 24 Outputs	Schematic multi-line	7/28/2022	EPLAN
	261	Control System: XC0302:Slot 25 Inputs	Schematic multi-line	7/28/2022	EPLAN
	280	Safety Circuit: Pneumatic Exhaust Valve	Schematic multi-line	7/6/2022	EPLAN
	281	Control System: Magnetic Door Locks	Schematic multi-line	7/28/2022	EPLAN
	282	Control System: Magnetic Door Locks	Schematic multi-line	7/5/2022	EPLAN
	284	Robot Safety Relay Connections	Schematic multi-line	7/27/2022	EPLAN
	286	Picking Robot Safety Relays	Schematic multi-line	7/28/2022	EPLAN
	290	Robot Controller Safety Breakouts	Schematic multi-line	7/27/2022	EPLAN
	305	XC4011 Picking Robot Controller IO	Schematic multi-line	7/28/2022	EPLAN
	306	XC4111 Picking Robot 1 Controller IO	Schematic multi-line	7/27/2022	EPLAN
	309	XC4121 Picking Robot 2 Controller IOs	Schematic multi-line	7/27/2022	EPLAN
	311	XC4131 Picking Robot 3 Controller Inputs	Schematic multi-line	7/28/2022	EPLAN
	312	XC41011 Picking Robot Controller IOs	Schematic multi-line	7/27/2022	EPLAN
	320	Control System: Vision System Camera	Schematic multi-line	7/28/2022	EPLAN
	330	Control System: Barcode Scan Cameras	Schematic multi-line	7/28/2022	EPLAN
=p780 +XC0401 Loader Valve Bank					
	002	Panel Label	Graphic	10/21/2019	pmelton
	300	Control System: XC0401 EtherCAT Node Overview	Schematic multi-line	7/27/2022	EPLAN
	301	Control System: XC0401.0 Digital Inputs 0-7	Schematic multi-line	6/29/2022	EPLAN
	302	Control System: XC0401.1 Digital Inputs 0-7	Schematic multi-line	7/28/2022	EPLAN
=p780 +XC4011 Picking Robot Controller					
	004	Panel Label	Graphic	6/30/2022	EPLAN

Table of contents

rmlA_TableofContents_004

Assignment	Page	Page description	Page type	Date	Edited by
=p780 +XC4011	Picking Robot Controller				
	005	OMRON Smart Controller Overview	Graphic	6/30/2022	EPLAN
	006	OMRON Smart Controller Panel	Graphic	7/6/2022	EPLAN
	007	OMRON Controller Overview	Graphic	7/28/2022	EPLAN
	008	Control System: Robot Network Connection	Schematic multi-line	7/27/2022	EPLAN
	009	Power Distribution: Power Connection	Schematic multi-line	7/6/2022	EPLAN
	100	Power Distribution: Main Power Connection	Schematic multi-line	7/5/2022	EPLAN
	101	Power Distribution: Main Power Connection	Schematic multi-line	7/5/2022	EPLAN
	102	Power Distribution: Main Power Connection	Schematic multi-line	7/6/2022	EPLAN
	200	System Safety: Robot Controller E-Stops	Schematic multi-line	7/28/2022	EPLAN
301	Control System: D50 Connector connection	Schematic multi-line	7/27/2022	EPLAN	
=p780 +RO4111	Picking Robot 1				
	003	Panel Label	Graphic	10/21/2019	pmelton
	004	Control System: D25 Connector connection	Schematic multi-line	7/27/2022	EPLAN
	005	Control System: Controller Inputs	Schematic multi-line	7/6/2022	EPLAN
=p780 +RO4121	Picking Robot 2				
	003	Panel Label	Graphic	10/21/2019	pmelton
	004	Control System: D25 Connector connection	Schematic multi-line	7/6/2022	EPLAN
	005	Control System: Controller Inputs	Schematic multi-line	7/6/2022	EPLAN
=p780 +RO4131	Picking Robot 3				
	003	Panel Label	Graphic	10/1/2021	EPLAN
	004	Control System: D25 Connector connection	Schematic multi-line	7/6/2022	EPLAN
	005	Control System: Controller Inputs	Schematic multi-line	7/6/2022	EPLAN
=p780 +RO4131	Picking Robot 3				
	006	Control System: Controller Outputs	Schematic multi-line	7/28/2022	EPLAN



Bector Automation RML Ltd

Kuruli, Tal-Khed
 410501 Pune
 Phone. +91 20 30781208

Company / customer Strides Pharma Ltd.
 Job number 16049-0301
 Project description p780 Sachet Cartoner

Area **p780**
 Mounting Loaction **CP0301**
 Mounting Description **Main Control Cabinet**

Created on 12/4/2016
 Edit date 8/29/2022 by (short name) EPLAN



TECHNICAL INFORMATION

=====

MAIN POWER SUPPLY	400 V AC
CONTROL VOLTAGE	24 VDC
EMERGENCY STOP CIRCUIT	Monitored to CAT4, Electrical Isolation CAT4 Pneumatic Insolation CAT4
INSTALLED CURRENT RATING	32A
CABINET SHORT CIRCUIT CURRENT	6kA
CUSTOMER SUPPLY RATING	40A
TYPE/SECTION POWER SUPPLY CABLE	TBA

COLOUR MARKING/WIRE IN CONTROL CABINET

=====

CODE	COLOUR
----	----
400VAC PHASE	RD/YE/BU
230VAC	RD
NEUTRAL	BK
PE/PEN	GN/YE
CONTROL VOLTAGE 24VDC +	BU
CONTROL VOLTAGE 24VDC: -	WH
PLC OUTPUT - DIGITAL	GY
PLC INPUT - DIGITAL	GY
SAFETY IO	YE

COLOUR CODE TABLE (IEC757)

=====

COLOUR	CODE
-----	----
BLACK	BK
BROWN	BN
RED	RD
ORANGE	OG
YELLOW	YE
GREEN	GN
BLUE	BU
VIOLET	VT
GREY	GY
WHITE	WH
PINK	PK
GOLD	GD
TURQUOISE	TQ
SILVER	SR
GREEN/YELLOW	GNYE

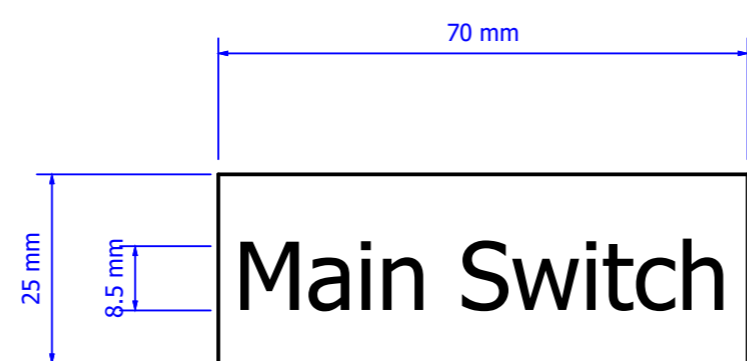
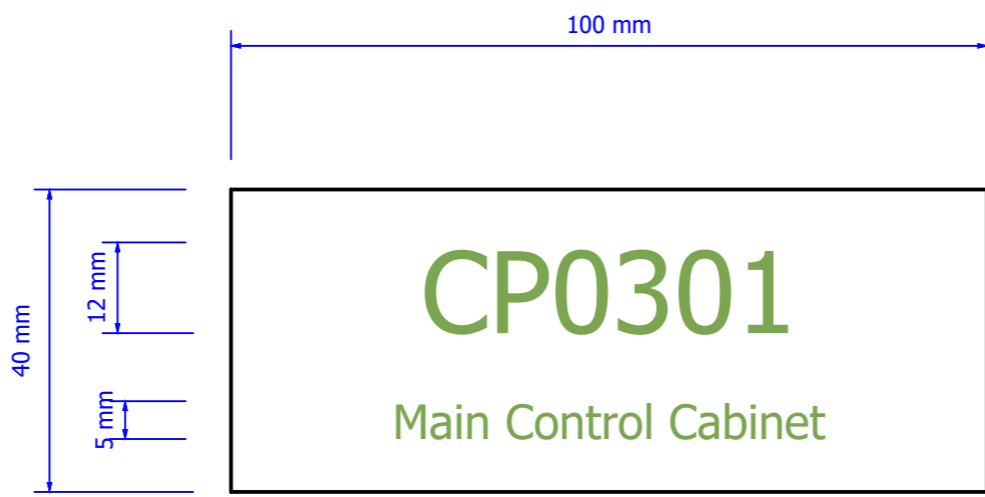

MATERIAL:- 1.6mm WBW TRAFFOLYTE OR PLASTIC
(BLACK LETTERS ON A WHITE BACKGROUND)
REVERSE ENGRAVED
AND SECURED WITH SILCONE.

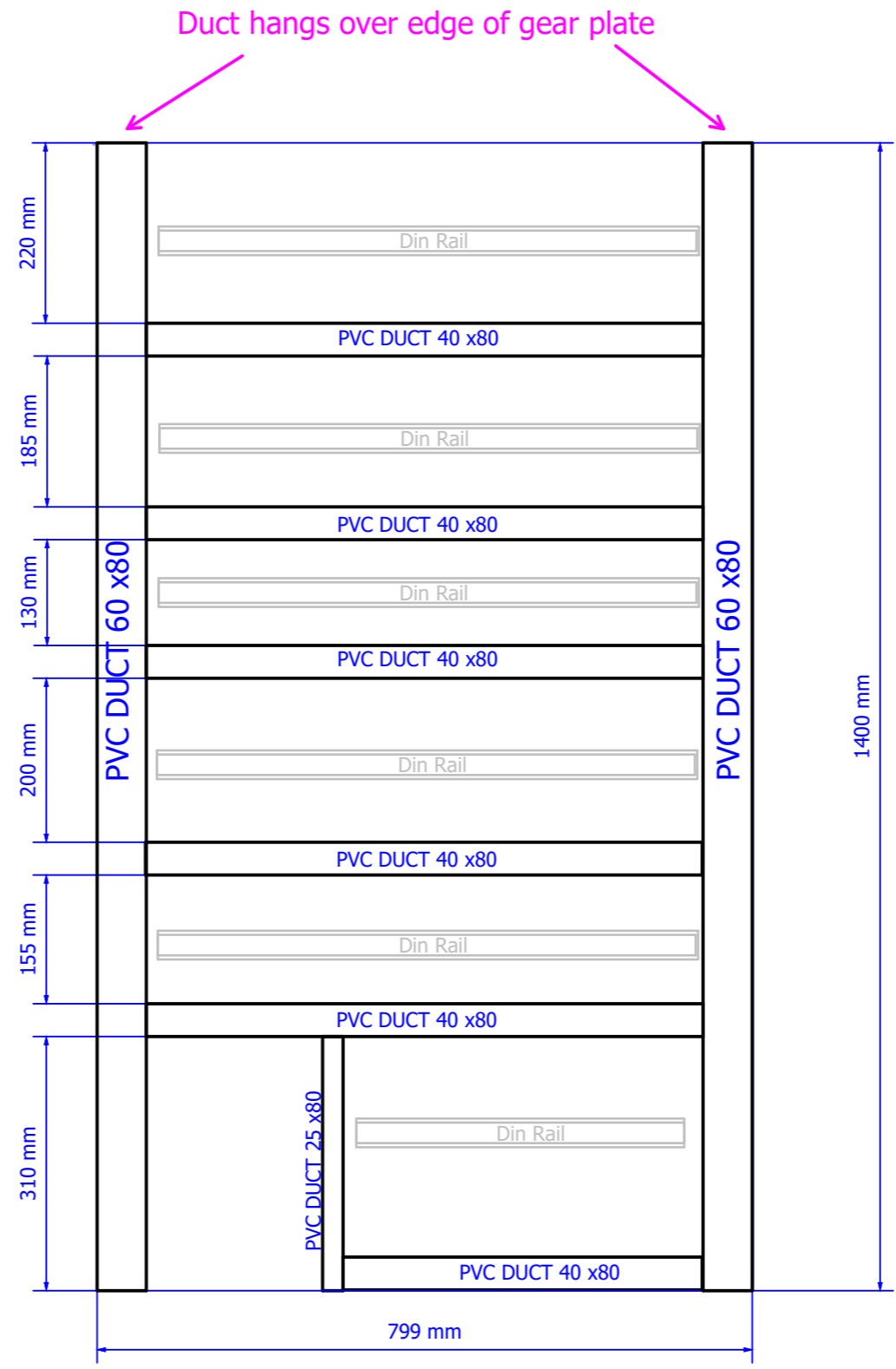

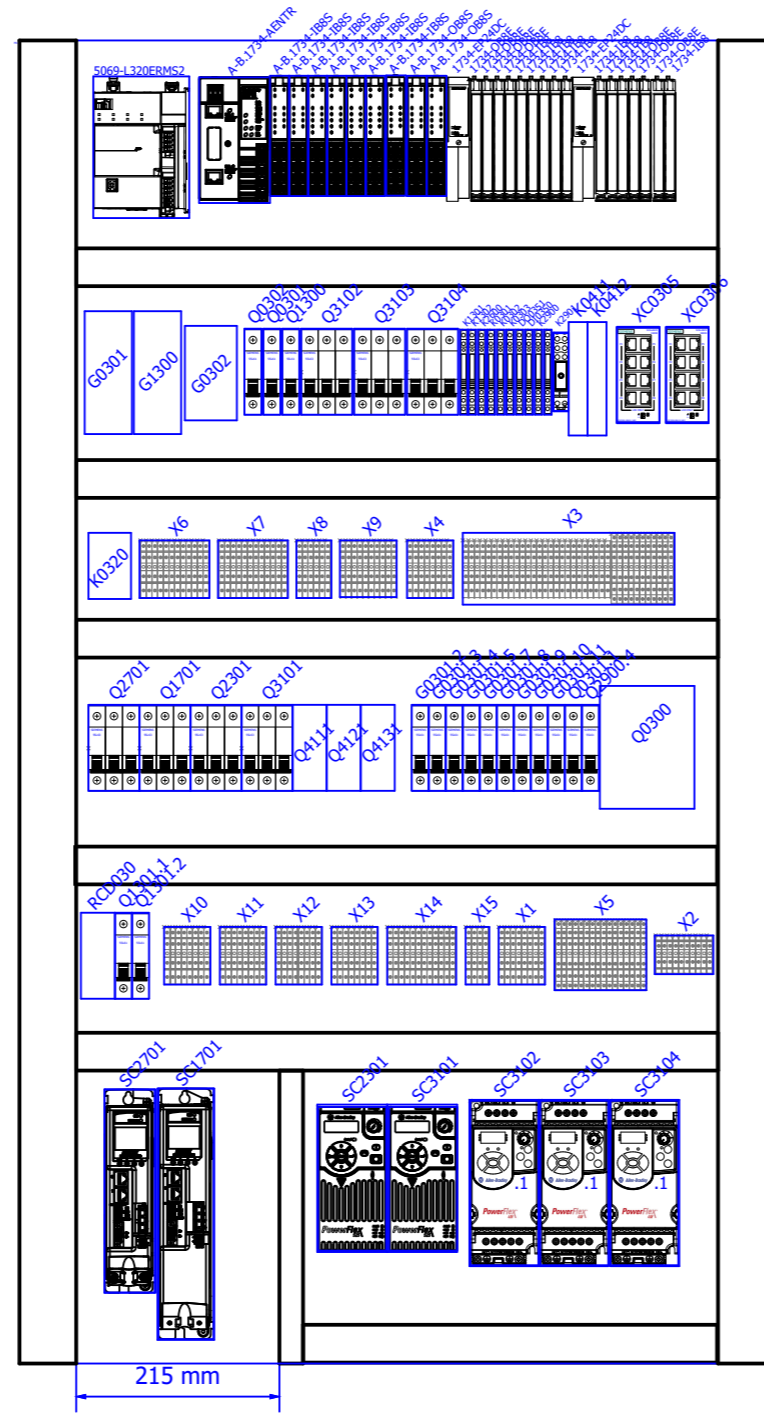

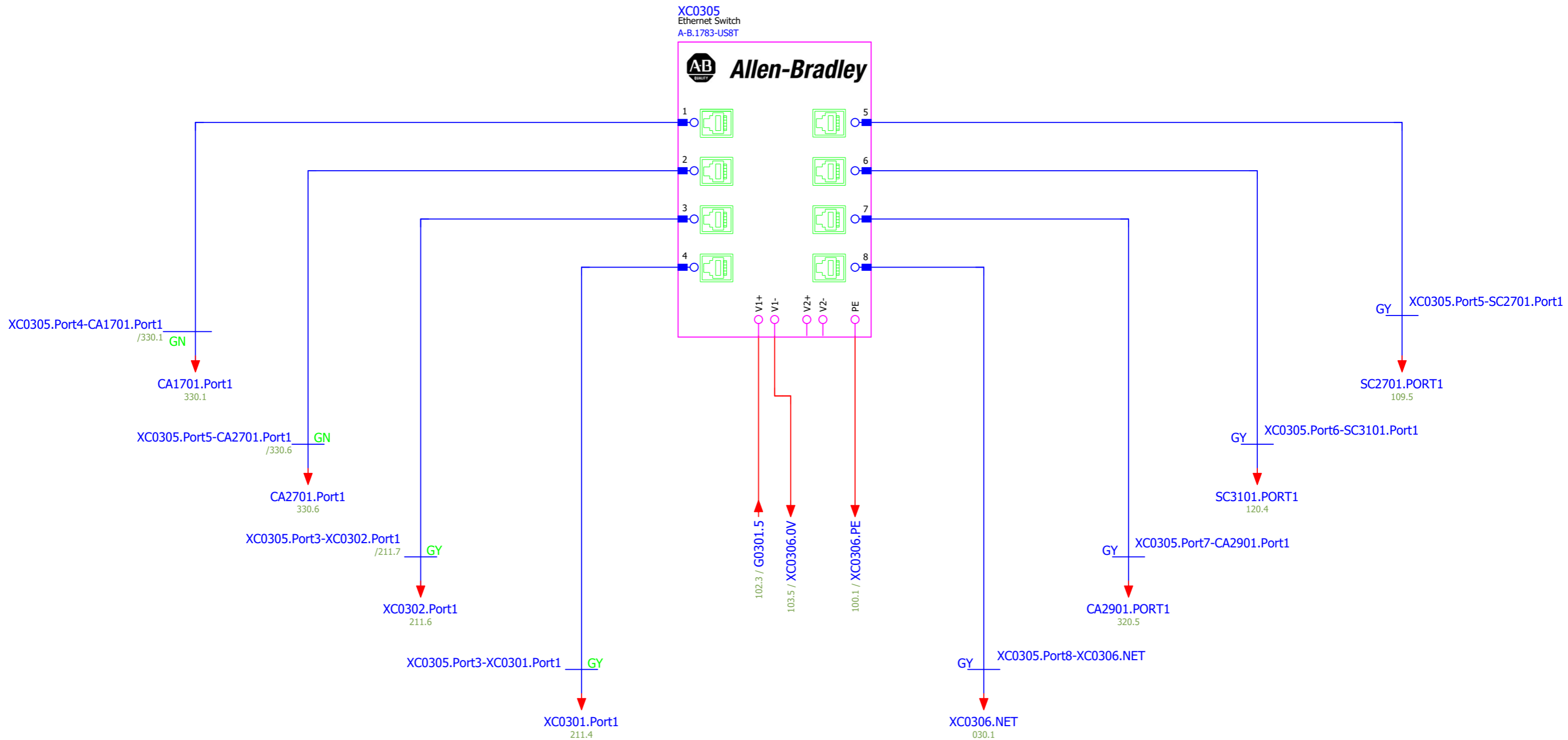

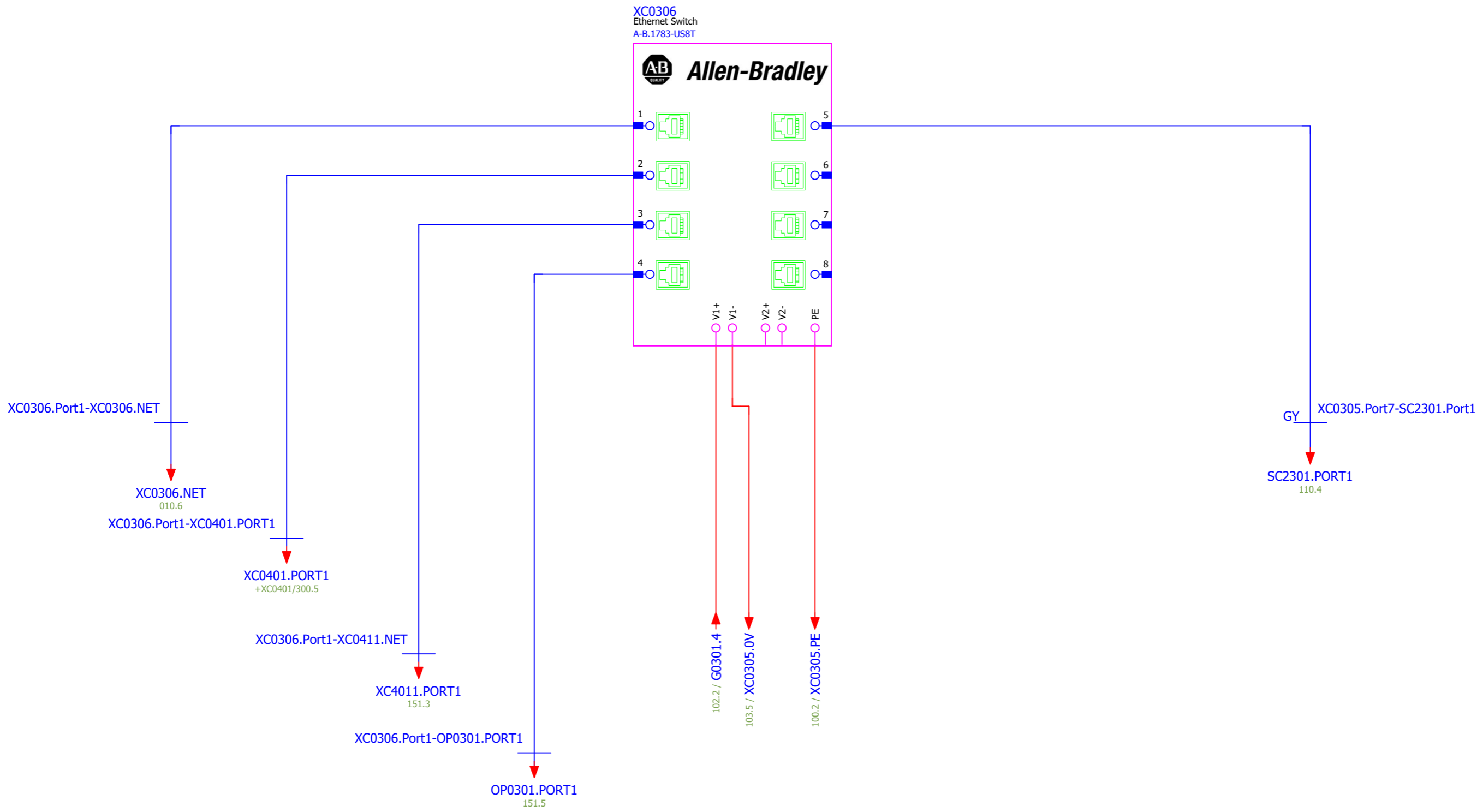

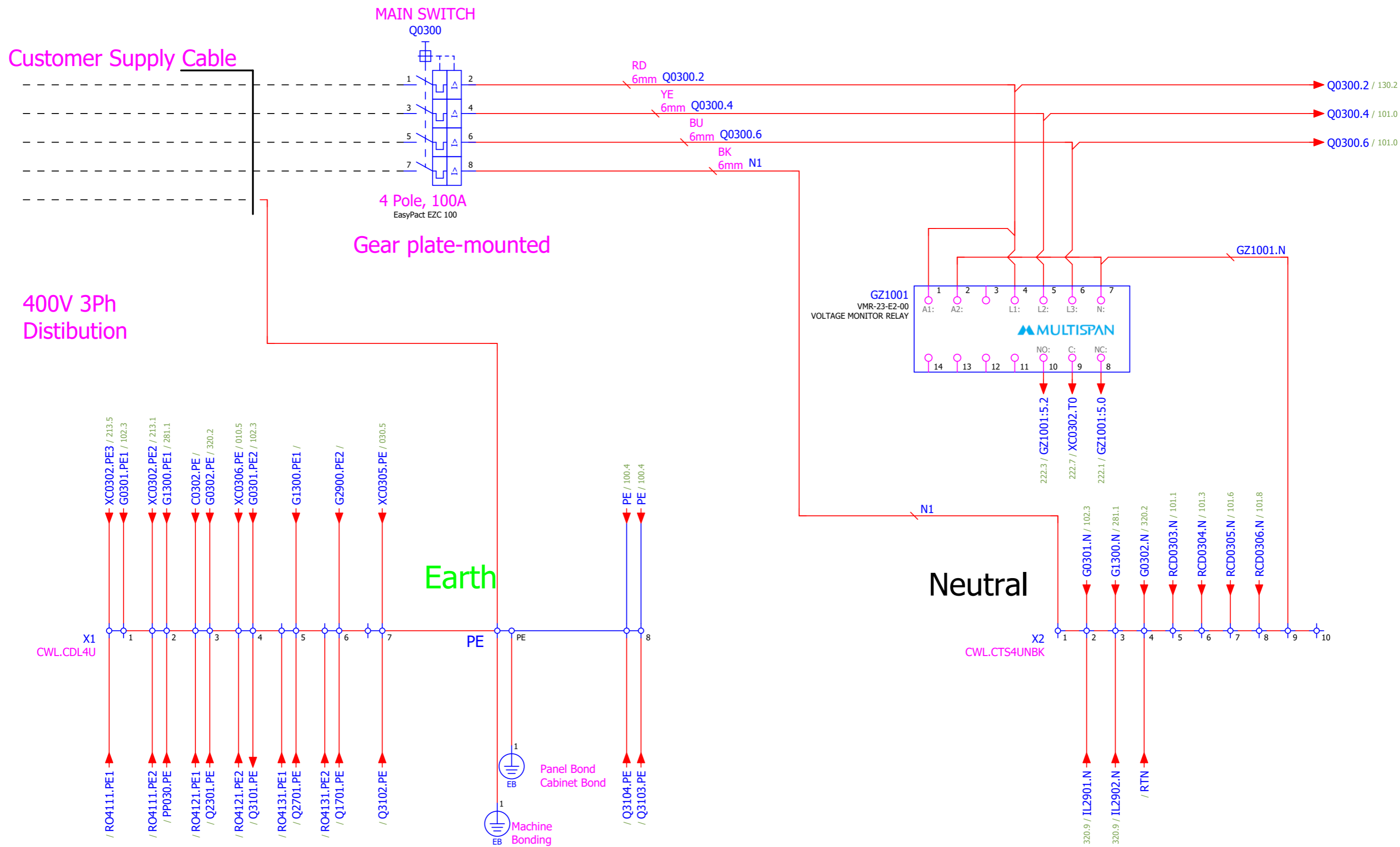

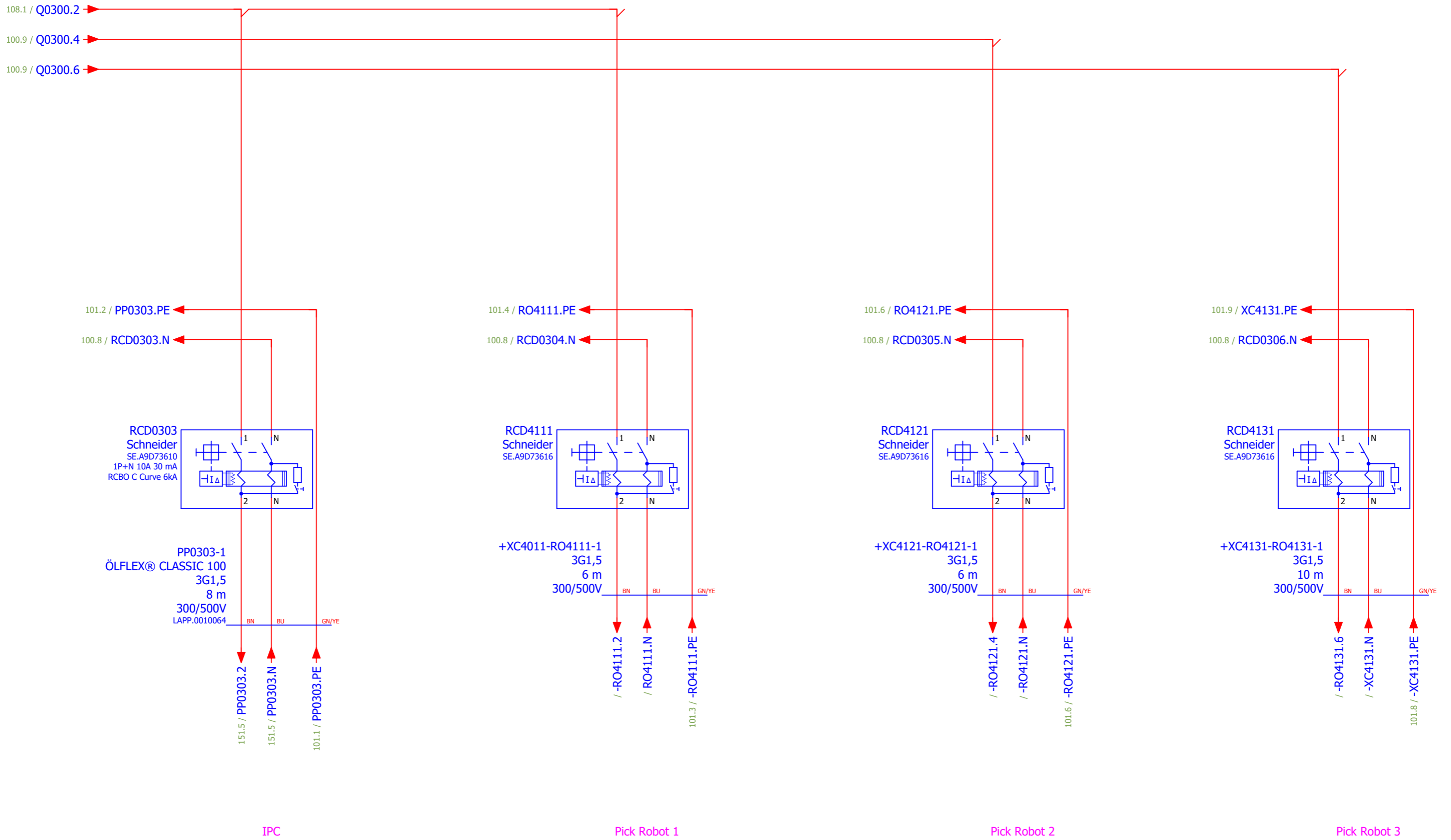

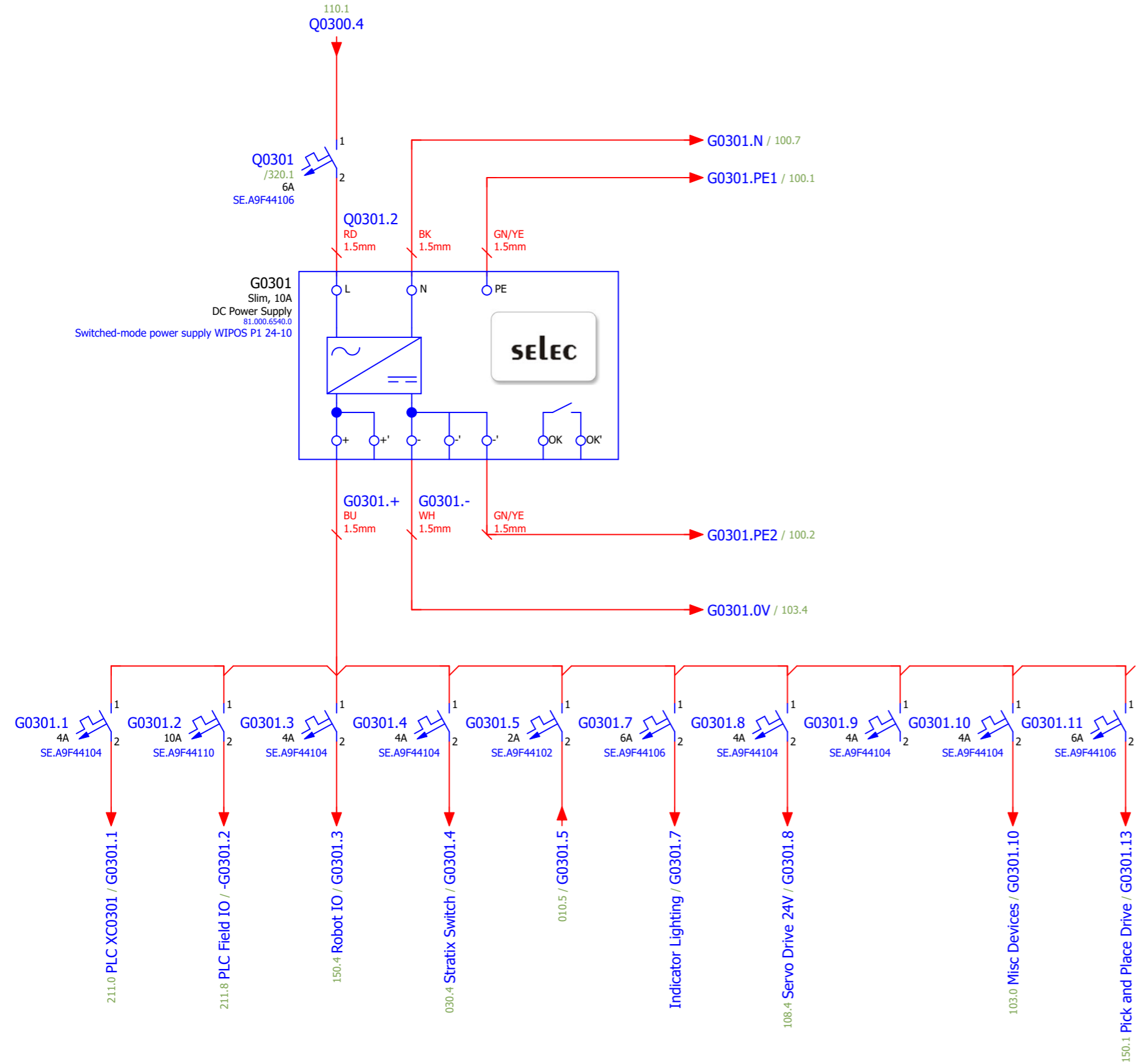

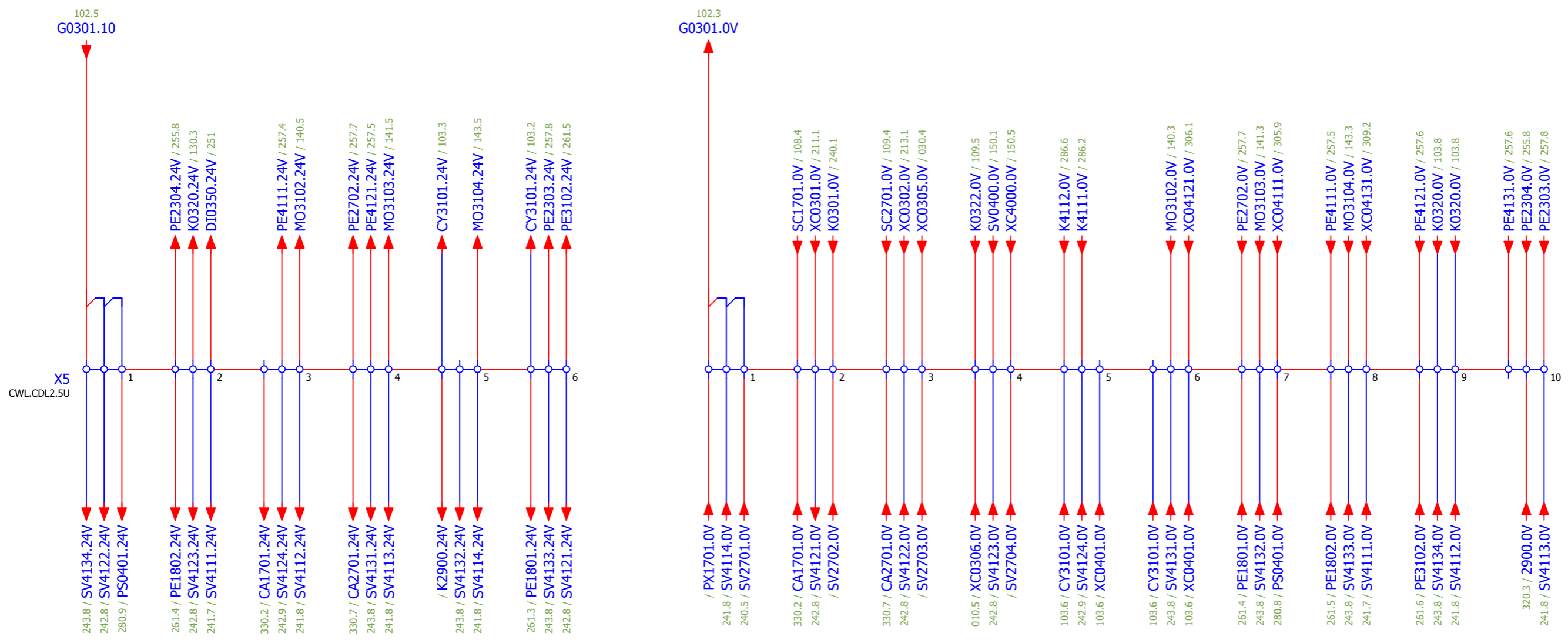

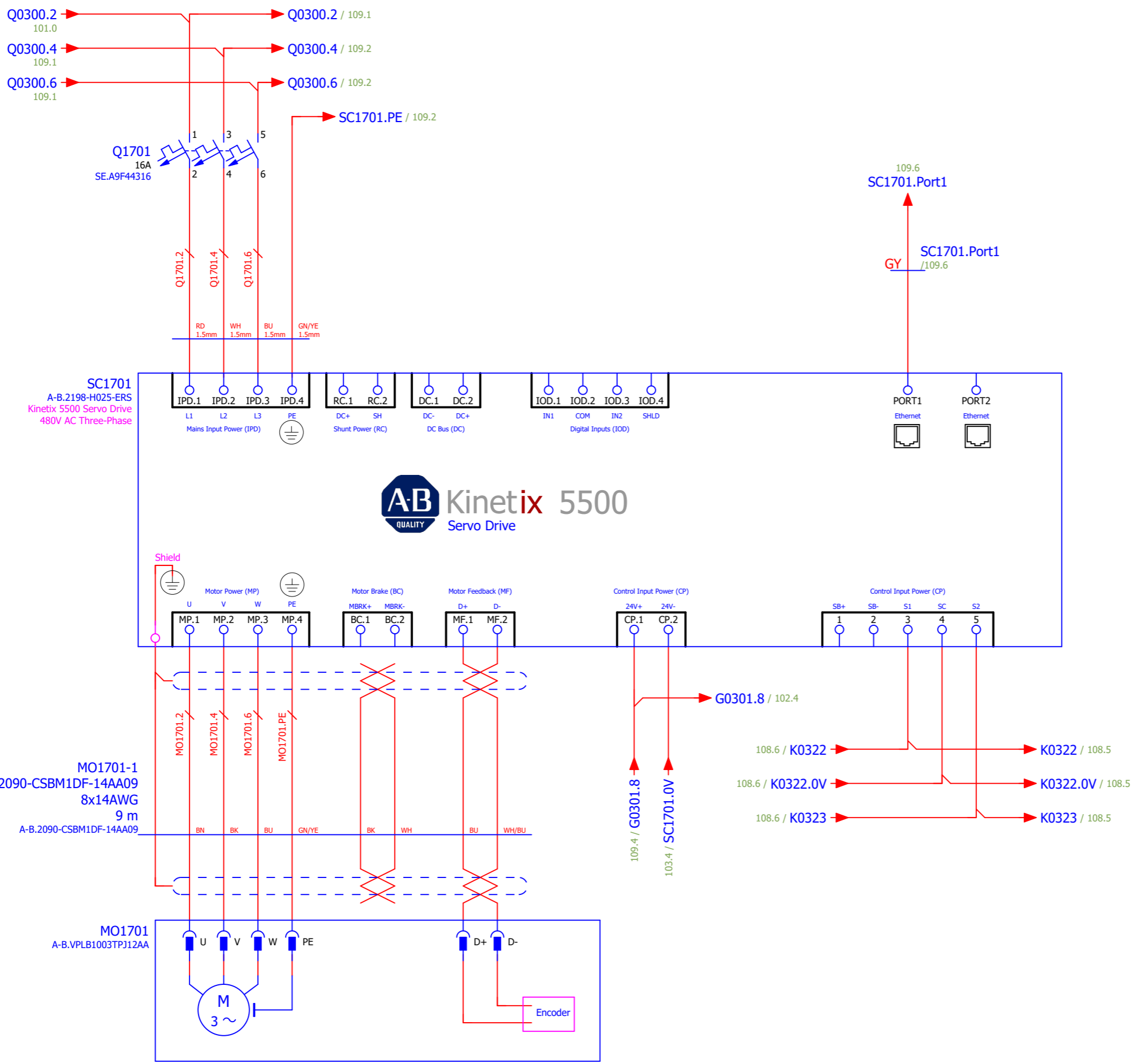

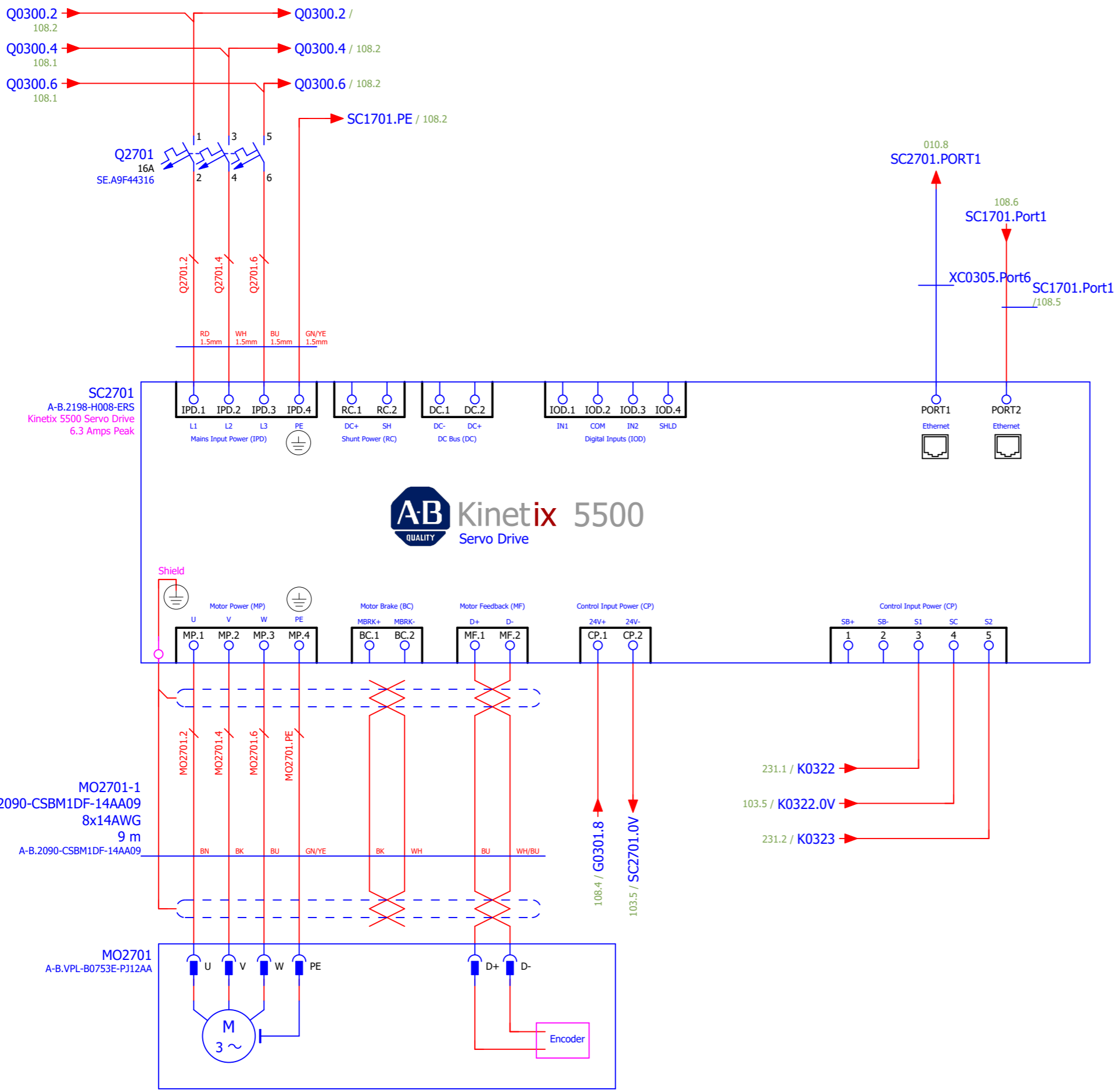

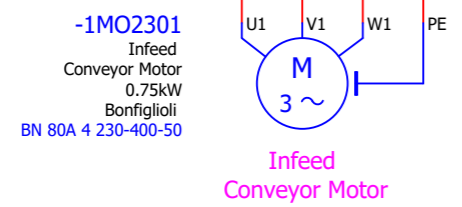
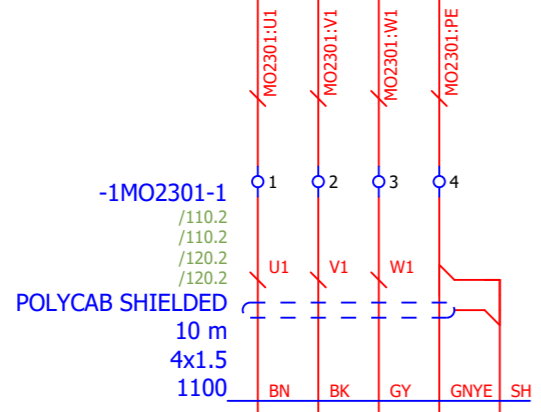
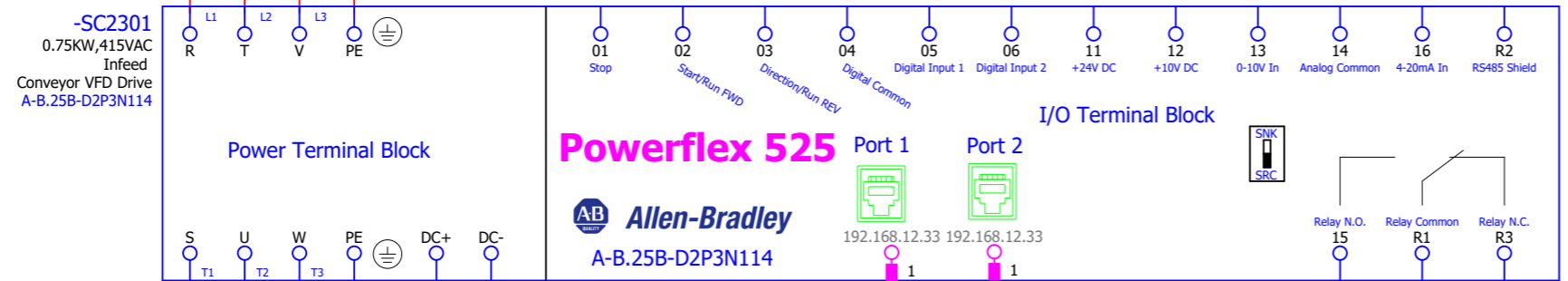
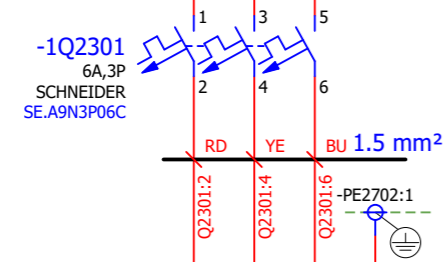
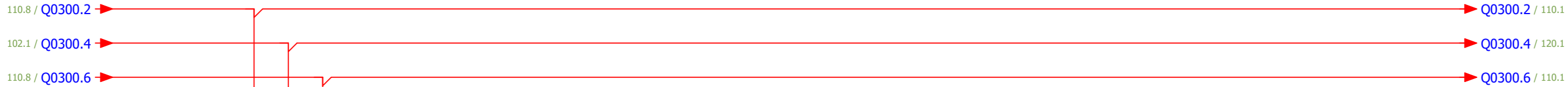

SC2301.PORT1
030.7

PARAM	NAME	UNITS	VALUE
P031	Motor NP Volts	V	415
P032	Motor NP Hertz	Hz	80
P033	Motor OL Current	A	0.8
P037	Motor NP Power	kw	0.25
P041	Accel Time 1	Sec	1
P042	Decel Time 1	Sec	1
P043	Minimum Freq	Hz	0
P044	Maximum Freq	Hz	130
P046	Start Source 1	-	5 (Ethernet I/P)
P047	Speed Source 1	-	15 (Ethernet I/P)
t064	Start Source x	-	0
C128	EN Addr Se	-	1 (Parameter)
C129	EN IP Addr Cfg 1	-	192 (IP Address)
C130	EN IP Addr Cfg 2	-	168 (IP Address)
C131	EN IP Addr Cfg 3	-	21 (IP Address)
C132	EN IP Addr Cfg 4	-	97 (IP Address)

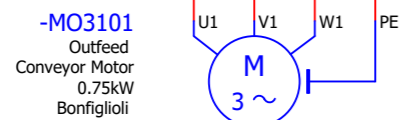
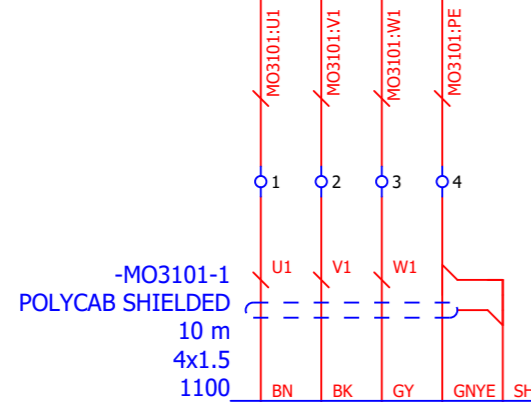
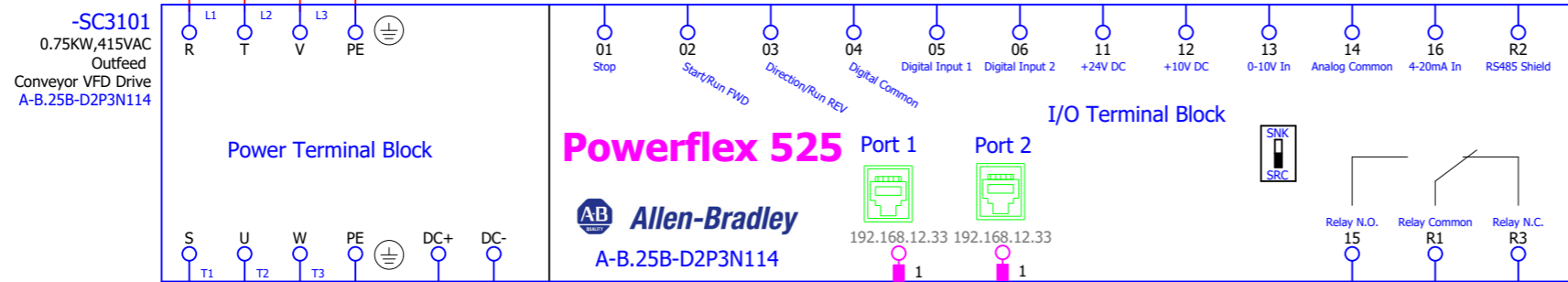
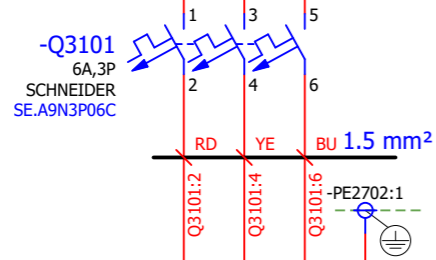
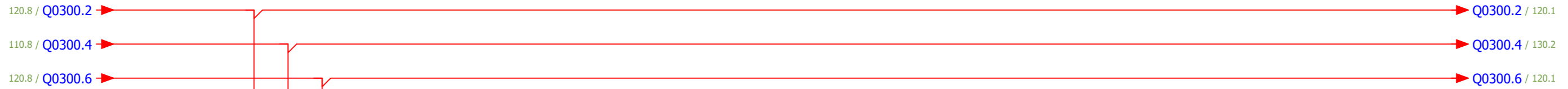

Infeed Conveyor Motor

SC3101.PORT1
010.8

PARAM	NAME	UNITS	VALUE
P031	Motor NP Volts	V	415
P032	Motor NP Hertz	Hz	80
P033	Motor OL Current	A	0.8
P037	Motor NP Power	kw	0.25
P041	Accel Time 1	Sec	1
P042	Decel Time 1	Sec	1
P043	Minimum Freq	Hz	0
P044	Maximum Freq	Hz	130
P046	Start Source 1	-	5 (Ethernet I/P)
P047	Speed Source 1	-	15 (Ethernet I/P)
t064	Start Source x	-	0
C128	EN Addr Se	-	1 (Parameter)
C129	EN IP Addr Cfg 1	-	192 (IP Address)
C130	EN IP Addr Cfg 2	-	168 (IP Address)
C131	EN IP Addr Cfg 3	-	21 (IP Address)
C132	EN IP Addr Cfg 4	-	97 (IP Address)

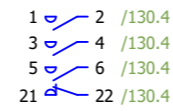
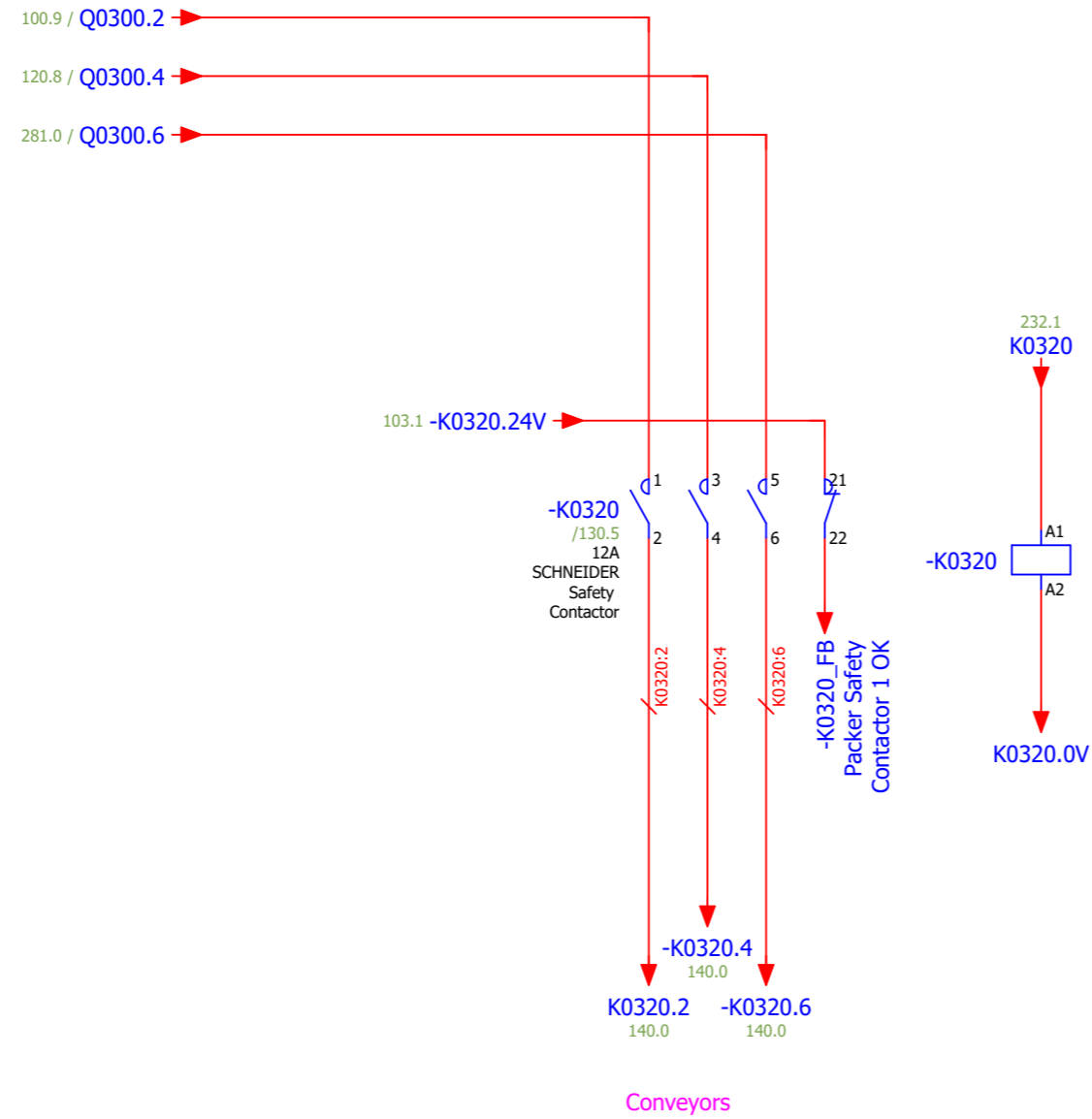

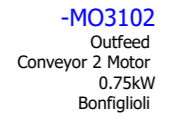
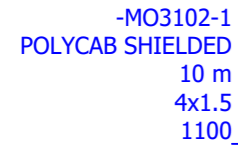
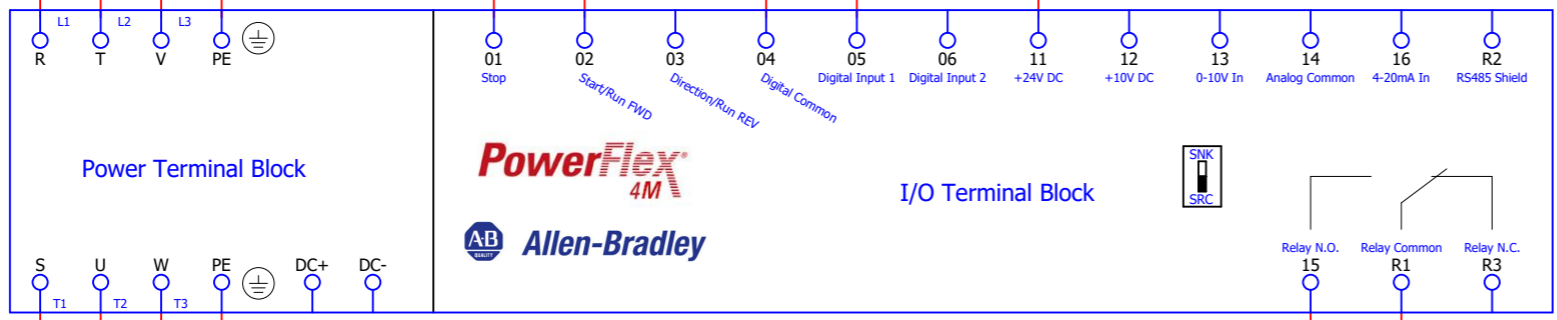
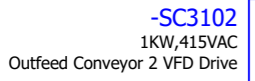
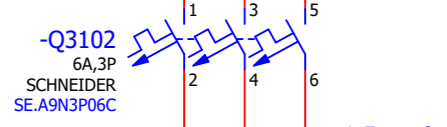
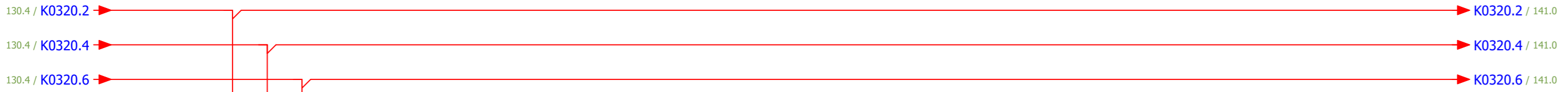

Conveyor Motor 2

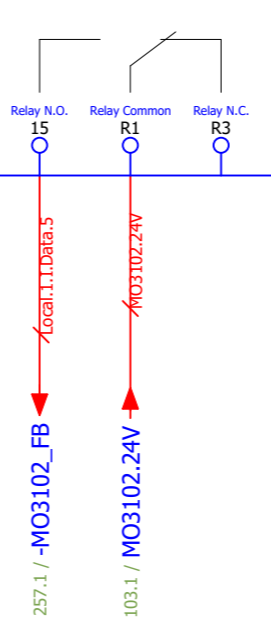

PARAM	NAME	UNITS	VALUE
101	Motor NP Volts	V	415
102	Motor NP Hertz	Hz	50
103	Motor OL Current	A	0.74
104	Minimum Frequency	Hz	15
105	Maximum Frequency	Hz	100
106	Start Source	-	2 (2-Wire)
108	Speed Reference	-	1 (Preset Freq)
109	Accel Time 1	Sec	1
110	Decel Time 1	Sec	1
201	Digital In1 Sel	-	7 (Clear Fault)
202	Digital In2 Sel	-	4 (Preset Freq)
221	Relay Out Sel	-	2 (Motor Running)
401	Accel Time 2	Sec	1
402	Decel Time 2	Sec	1
410	Preset Freq 0	Hz	25
412	Preset Freq 2	Hz	30

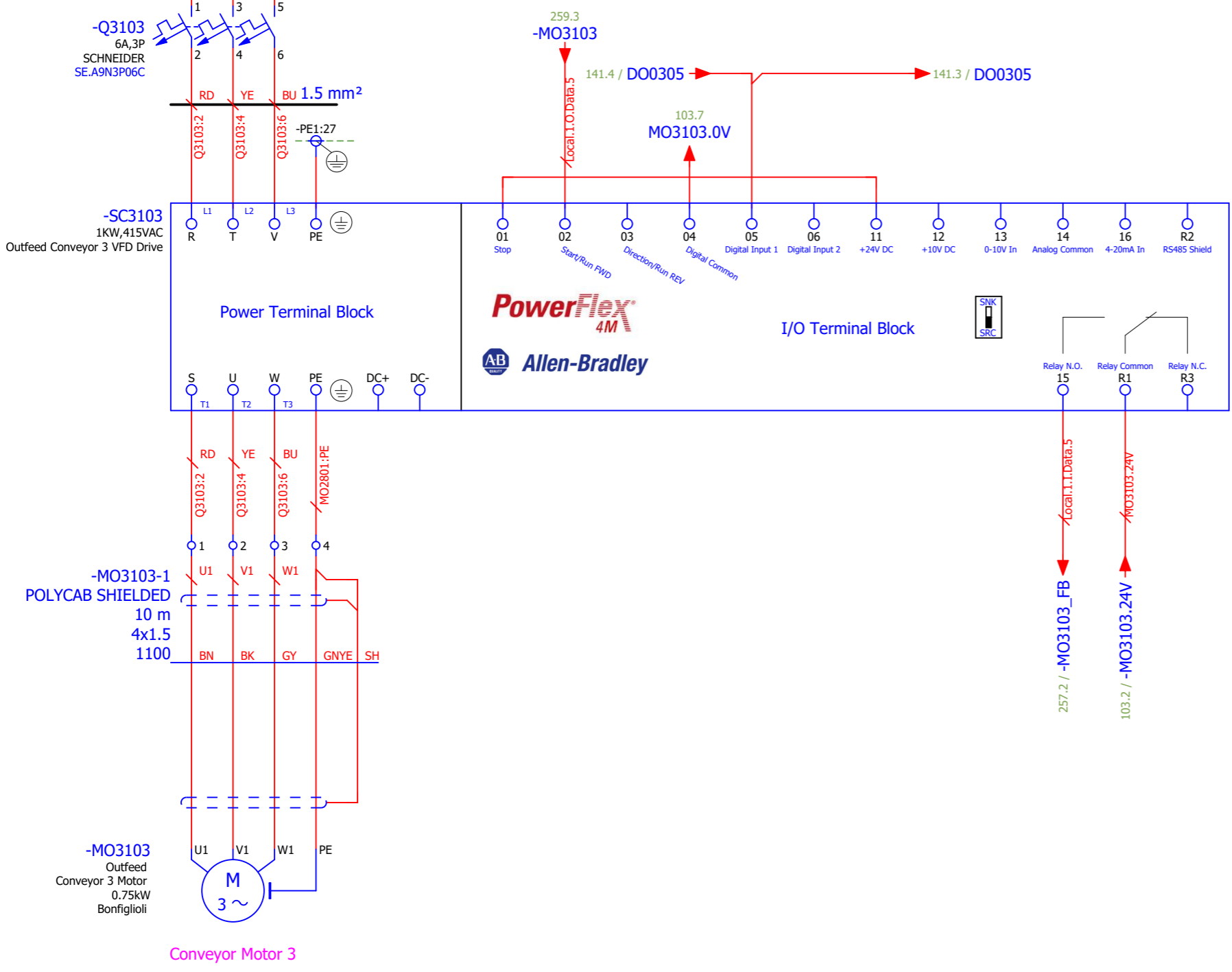
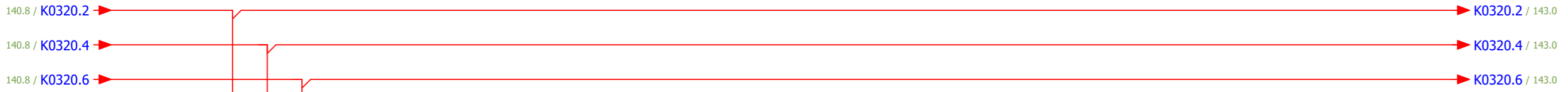

PARAM	NAME	UNITS	VALUE
101	Motor NP Volts	V	415
102	Motor NP Hertz	Hz	50
103	Motor OL Current	A	0.74
104	Minimum Frequency	Hz	15
105	Maximum Frequency	Hz	100
106	Start Source	-	2 (2-Wire)
108	Speed Reference	-	1 (Preset Freq)
109	Accel Time 1	Sec	1
110	Decel Time 1	Sec	1
201	Digital In1 Sel	-	7 (Clear Fault)
202	Digital In2 Sel	-	4 (Preset Freq)
221	Relay Out Sel	-	2 (Motor Running)
401	Accel Time 2	Sec	1
402	Decel Time 2	Sec	1
410	Preset Freq 0	Hz	25
412	Preset Freq 2	Hz	30

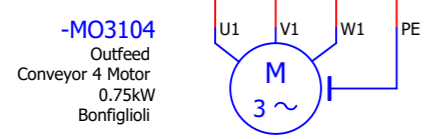
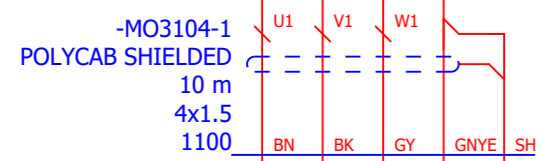
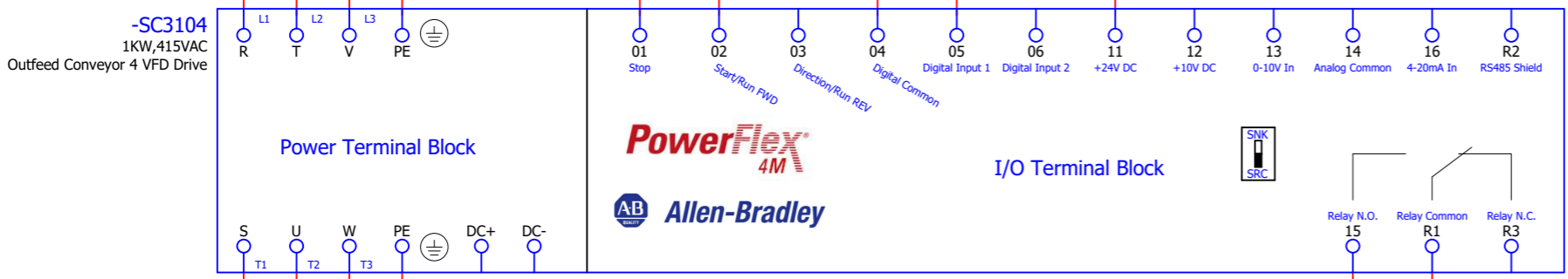
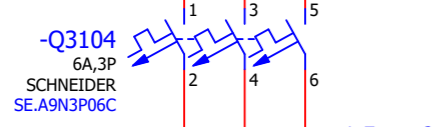
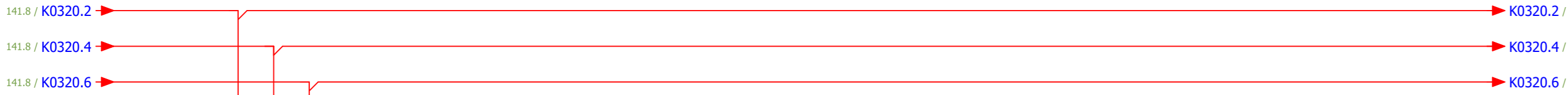

Conveyor Motor 4

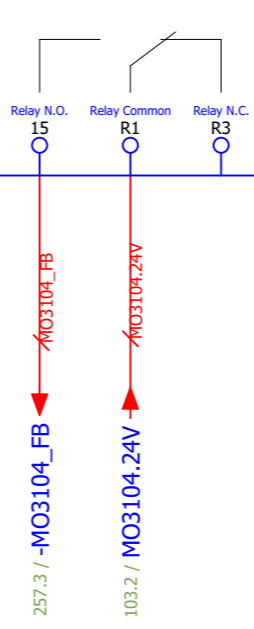

PARAM	NAME	UNITS	VALUE
101	Motor NP Volts	V	415
102	Motor NP Hertz	Hz	50
103	Motor OL Current	A	0.74
104	Minimum Frequency	Hz	15
105	Maximum Frequency	Hz	100
106	Start Source	-	2 (2-Wire)
108	Speed Reference	-	1 (Preset Freq)
109	Accel Time 1	Sec	1
110	Decel Time 1	Sec	1
201	Digital In1 Sel	-	7 (Clear Fault)
202	Digital In2 Sel	-	4 (Preset Freq)
221	Relay Out Sel	-	2 (Motor Running)
401	Accel Time 2	Sec	1
402	Decel Time 2	Sec	1
410	Preset Freq 0	Hz	25
412	Preset Freq 2	Hz	30

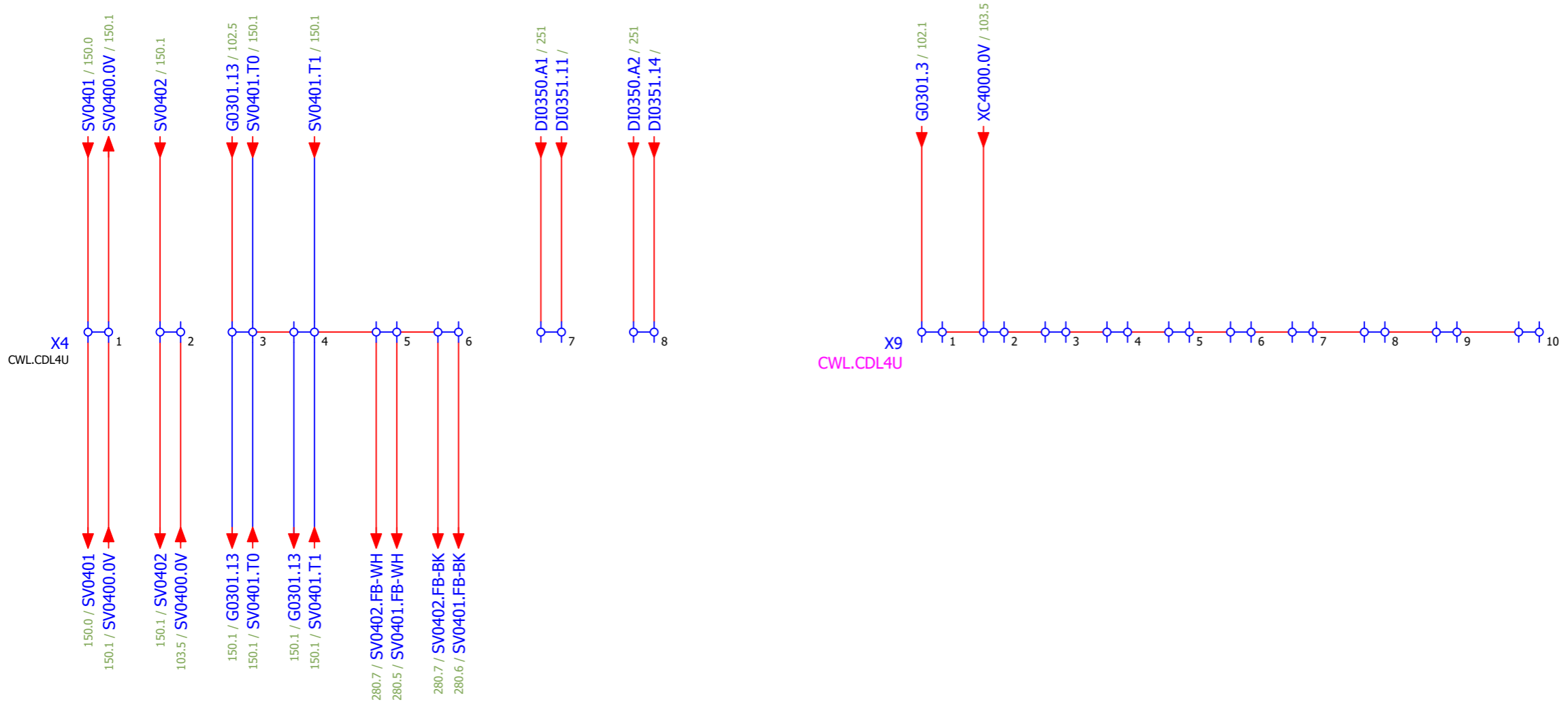

Dump Valve Connections

Up/Downstream Connections

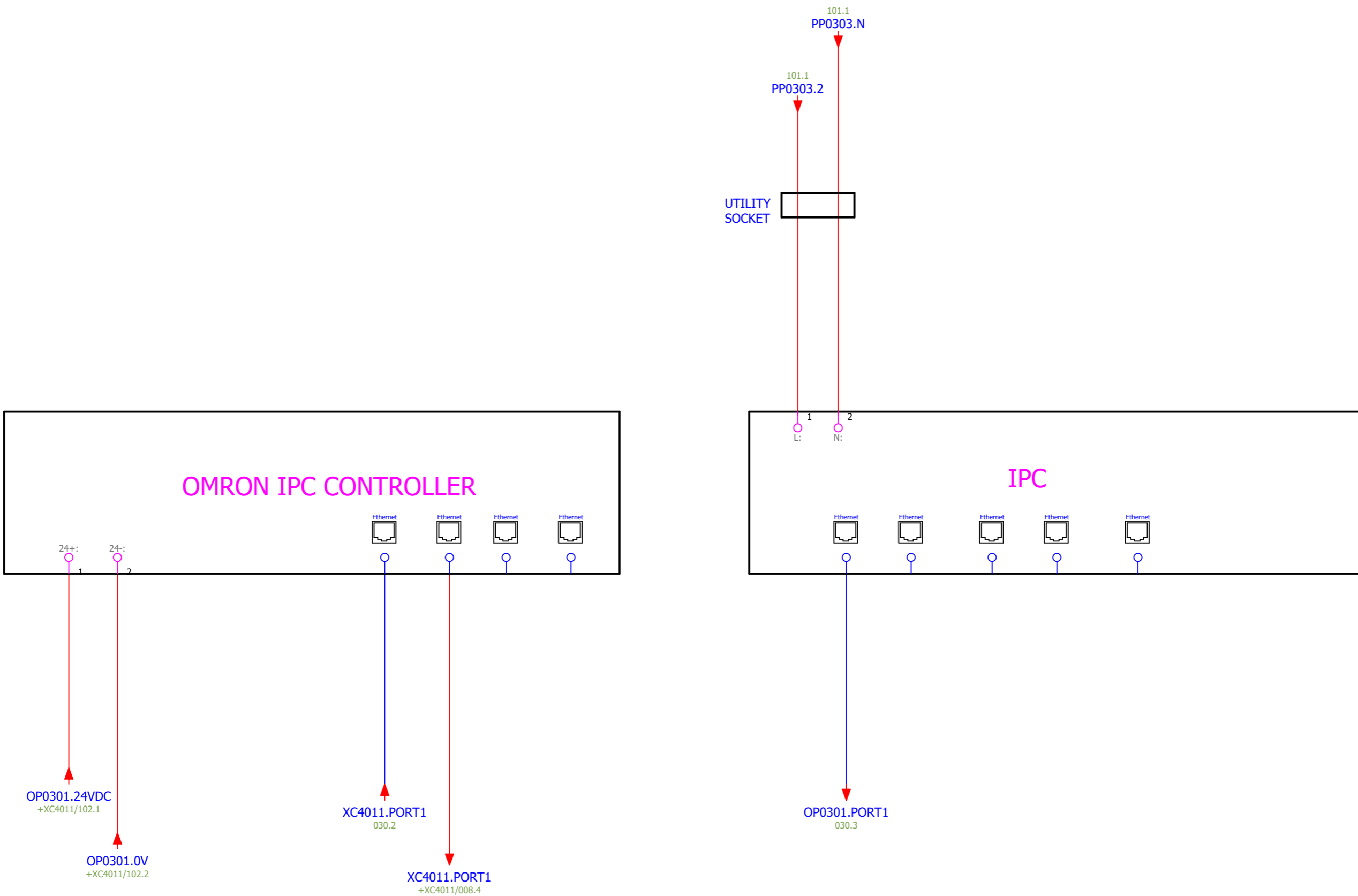

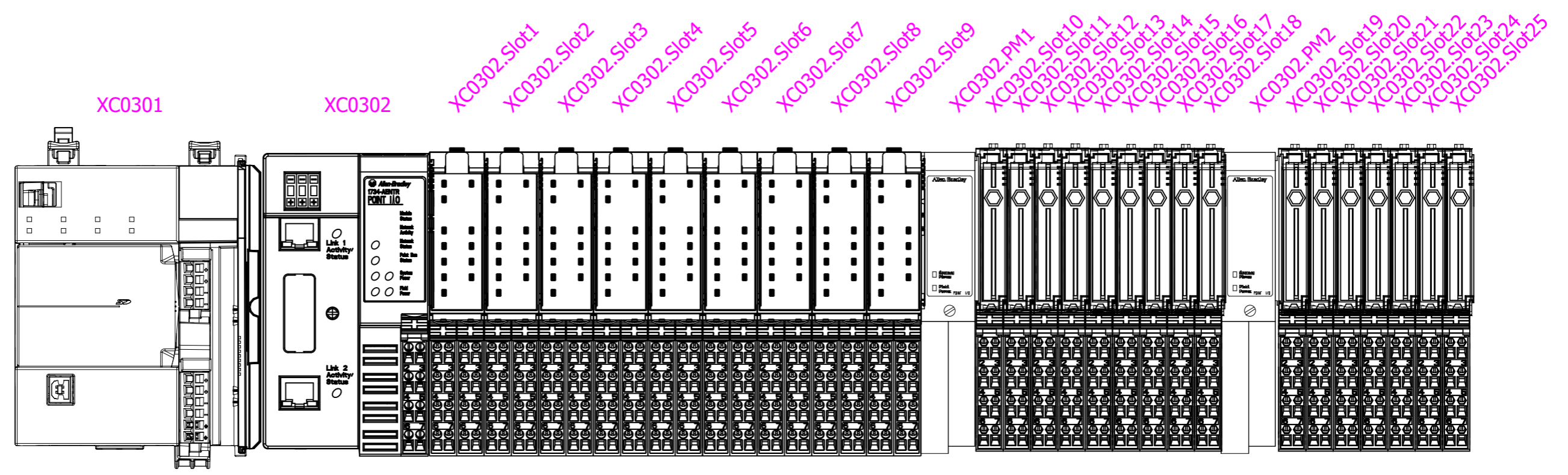

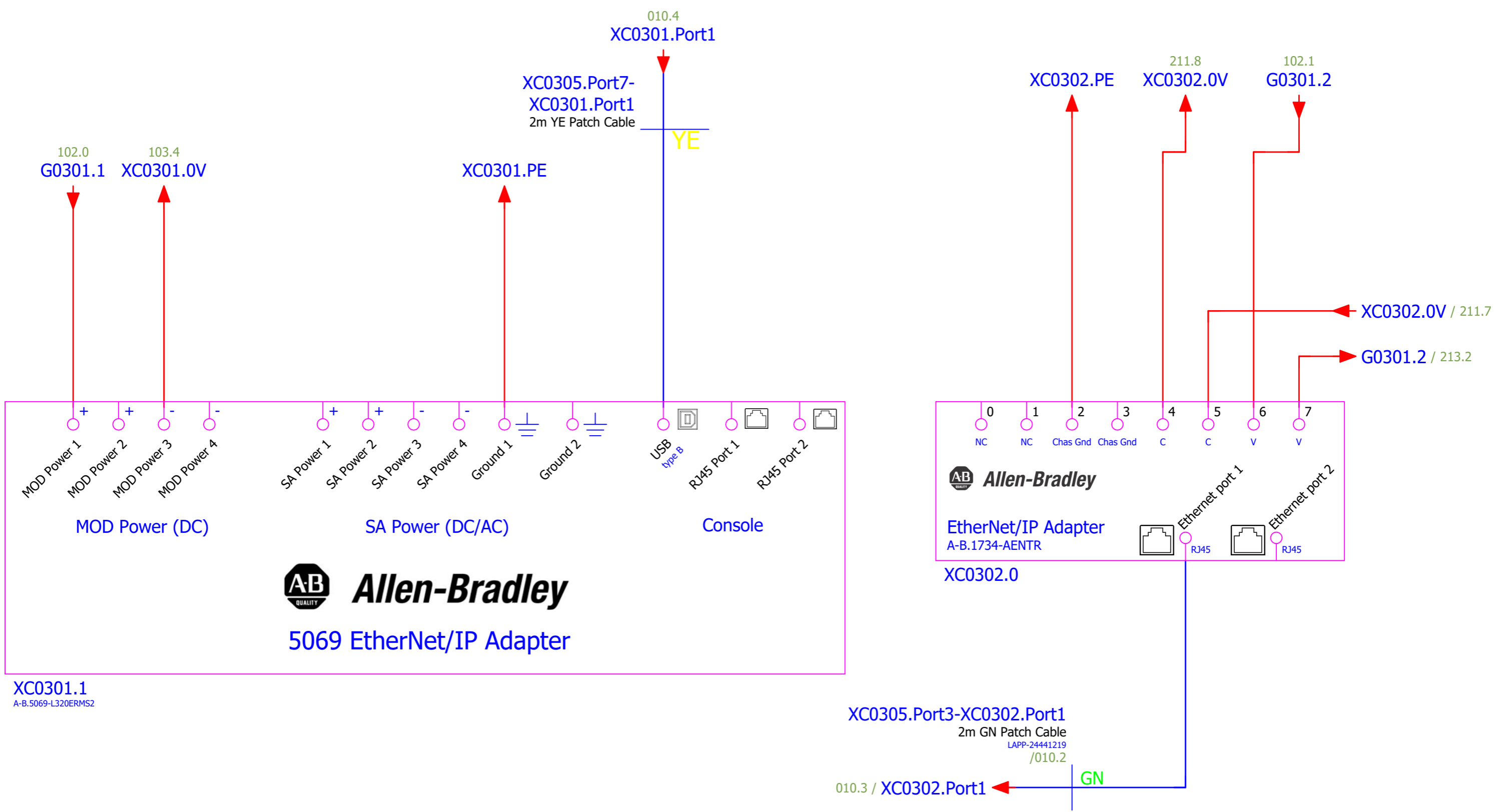

XC0301.1
A-B.5069-L320ERMS2

XC0305.Port3-XC0302.Port1
2m GN Patch Cable
LAPP-24441219
/010.2

010.3 / XC0302.Port1

0 1 2 3 4 5 6 7 8 9



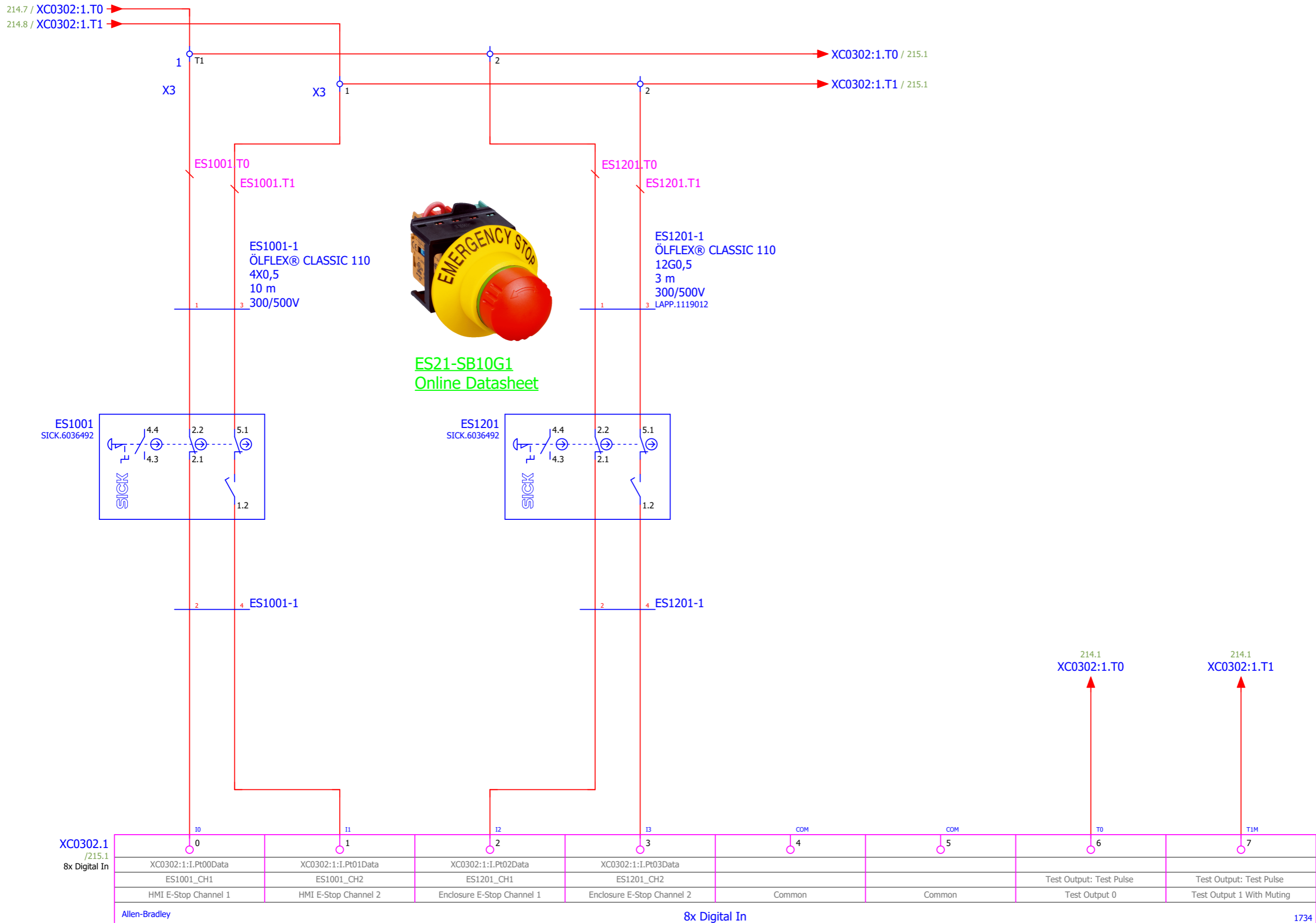

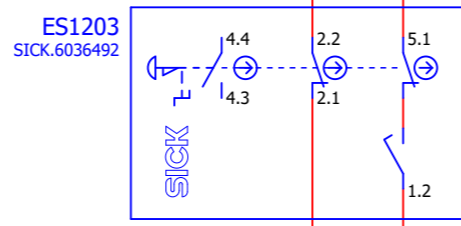
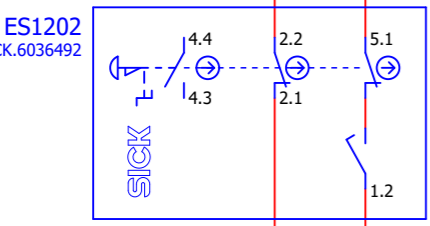
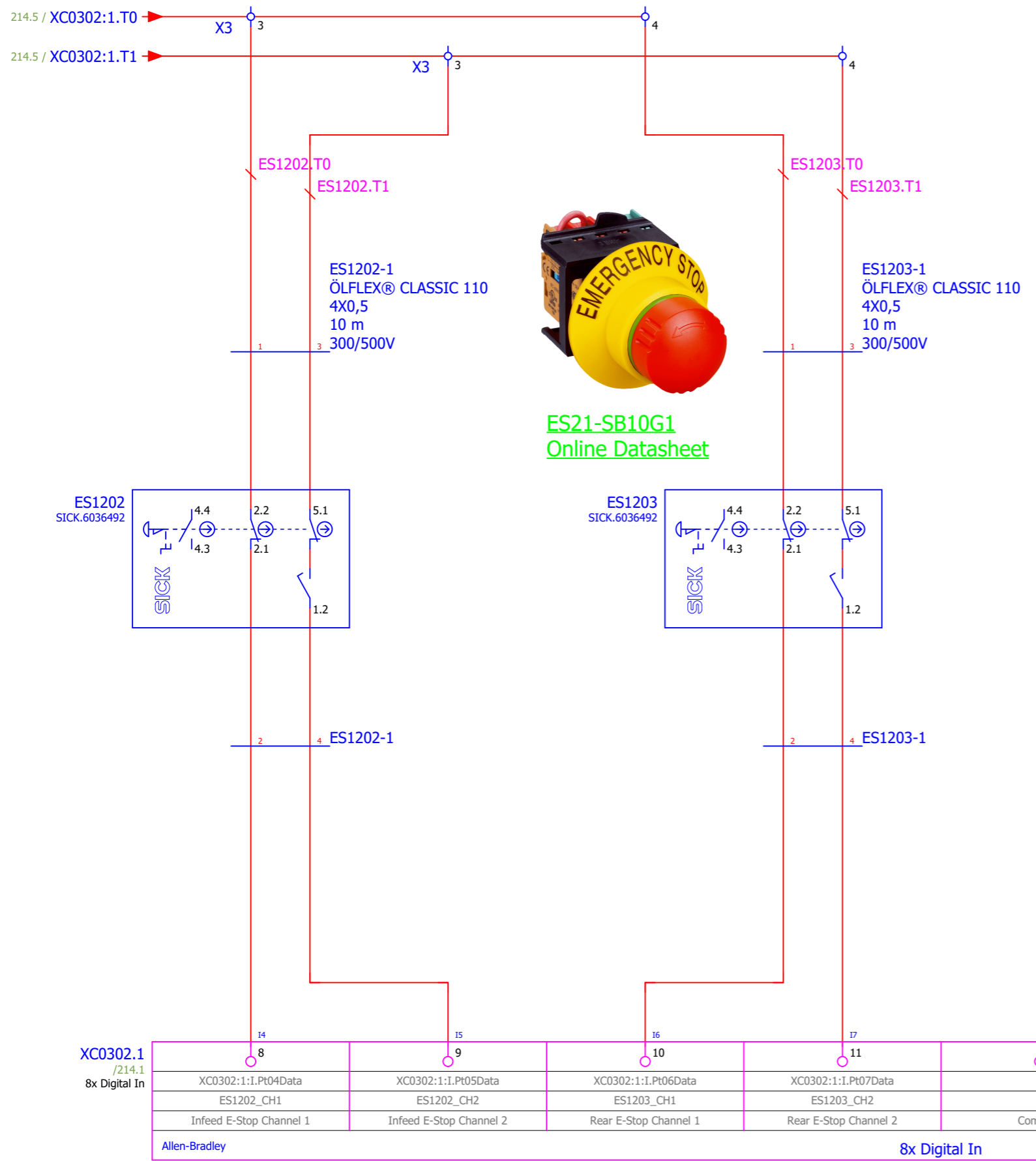

XC0302.1 /Z14.1 8x Digital In	14	15	16	17	COM	COM	T2	T3M
	8	9	10	11	12	13	14	15
	XC0302:1:I.Pt04Data	XC0302:1:I.Pt05Data	XC0302:1:I.Pt06Data	XC0302:1:I.Pt07Data				
	ES1202_CH1	ES1202_CH2	ES1203_CH1	ES1203_CH2			Test Output: Test Pulse	Test Output: Test Pulse
	Infeed E-Stop Channel 1	Infeed E-Stop Channel 2	Rear E-Stop Channel 1	Rear E-Stop Channel 2	Common	Common	Test Output 2	Test Output 3 With Muting
Allen-Bradley								
8x Digital In								



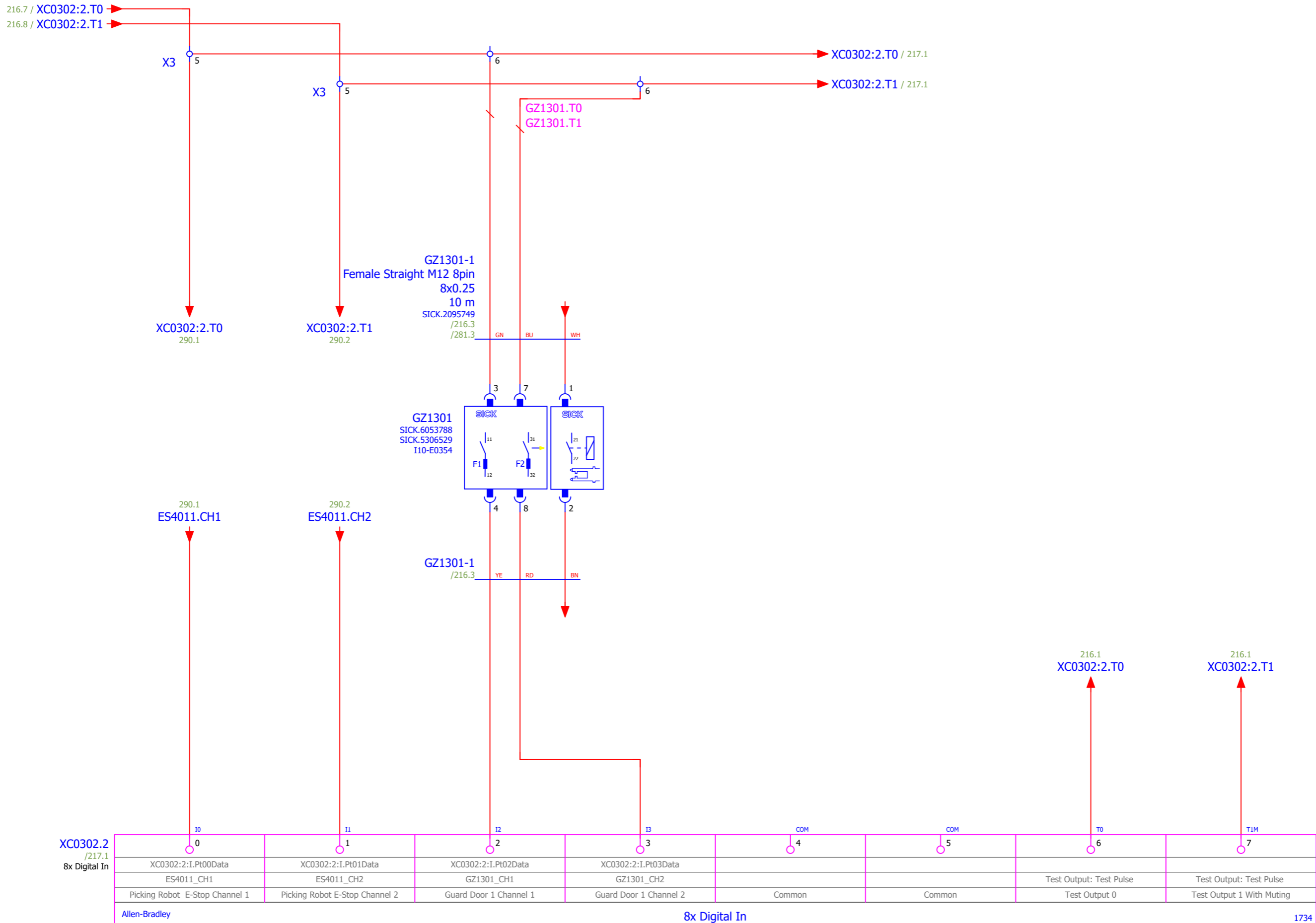

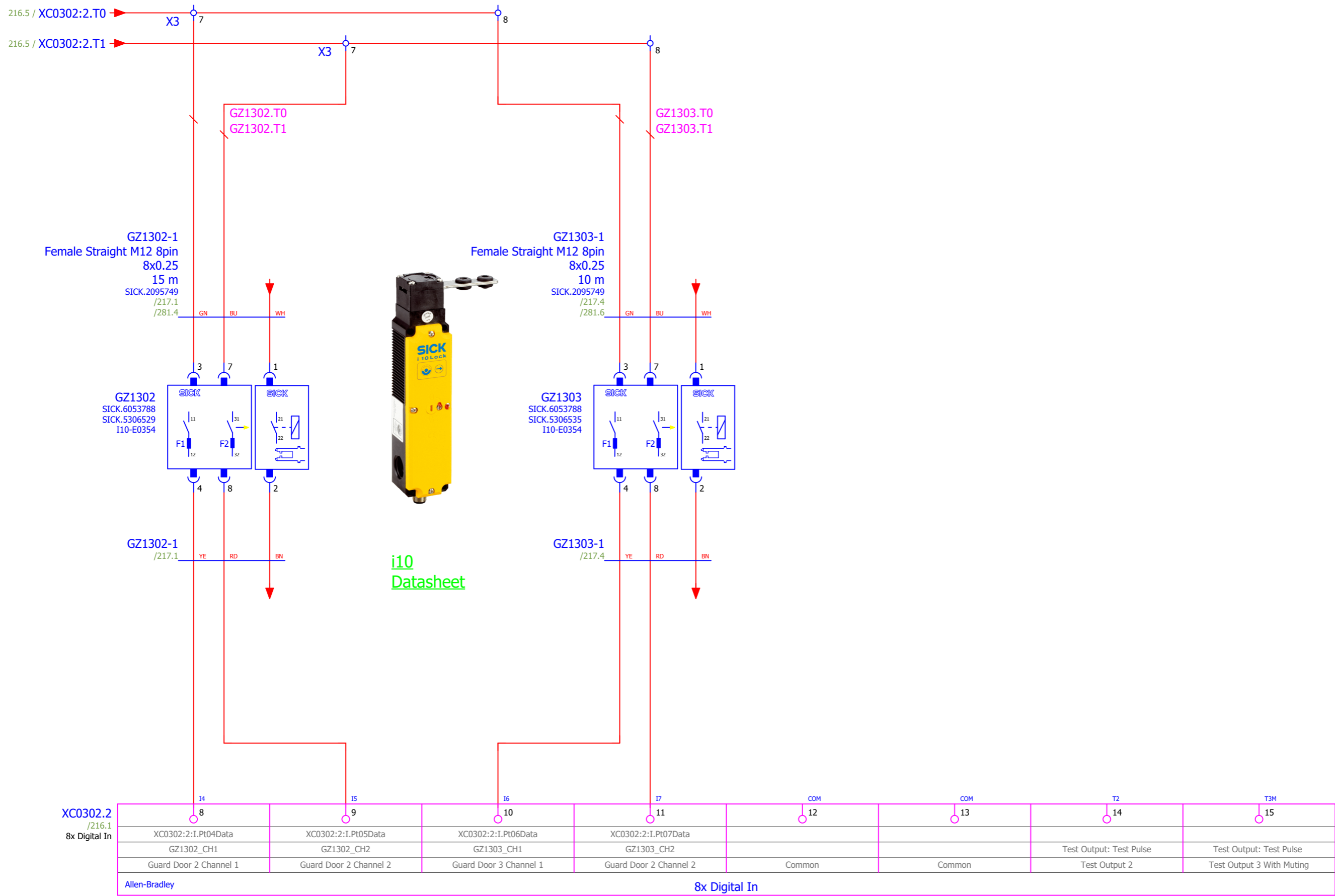

[i10 Datasheet](#)



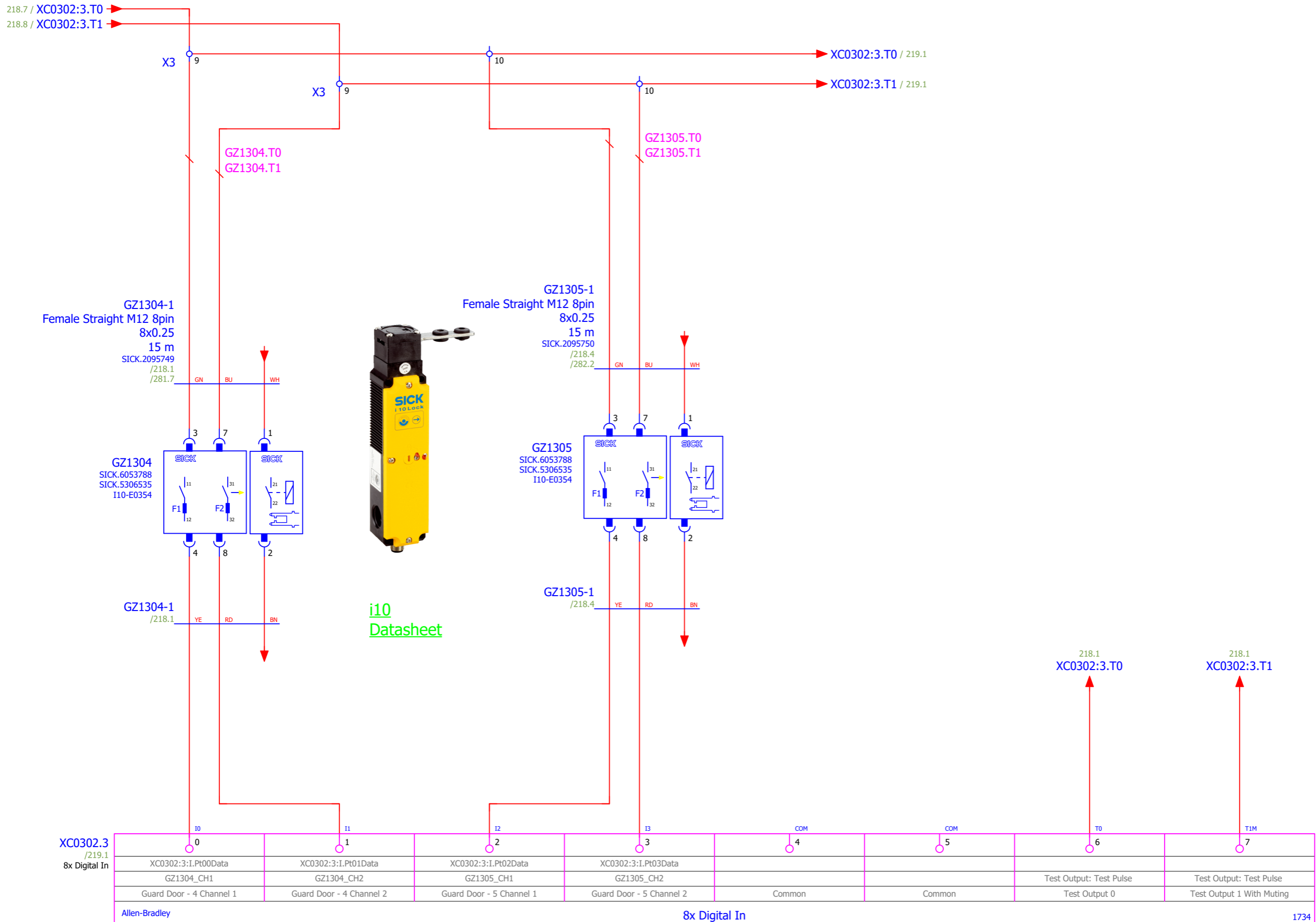

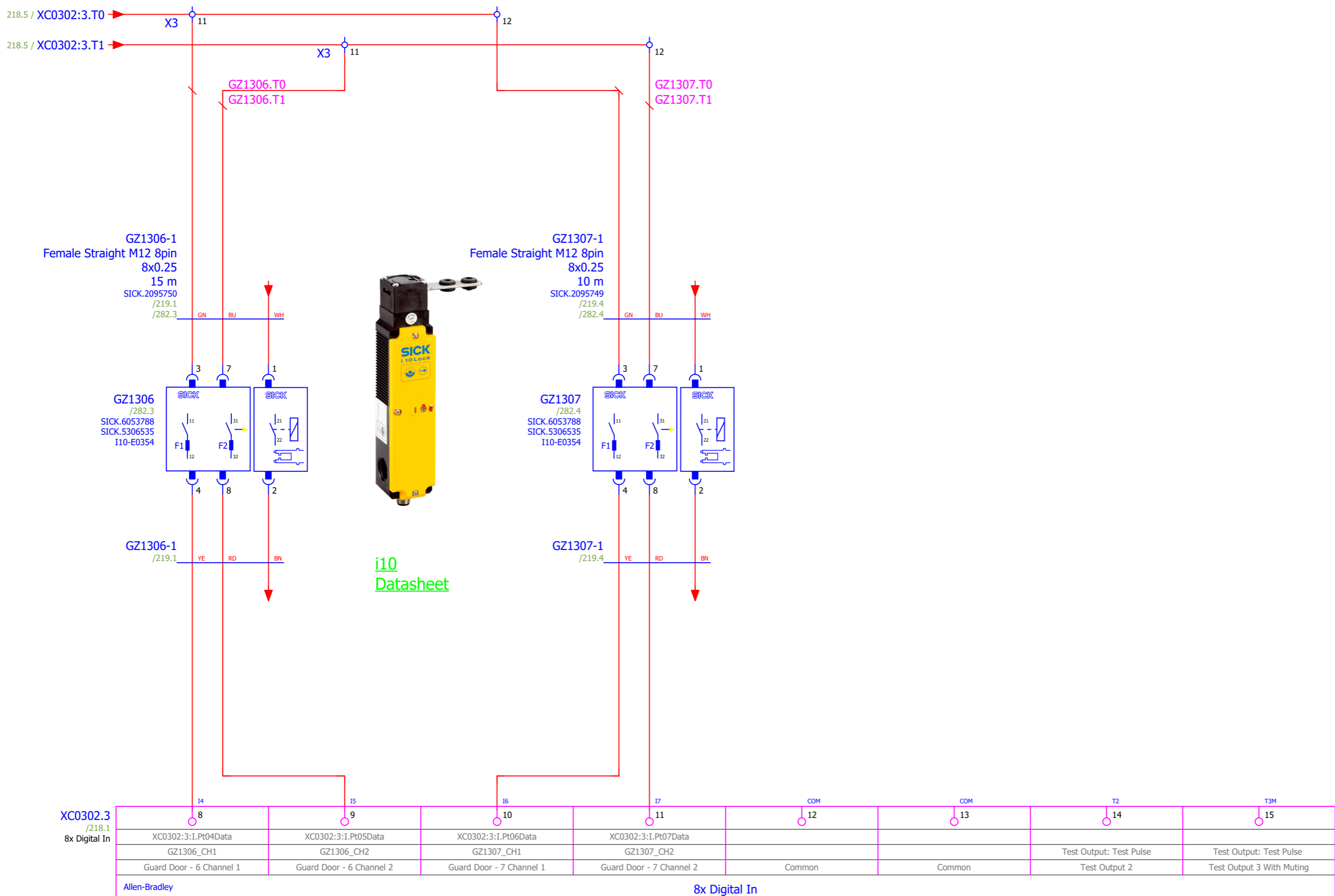

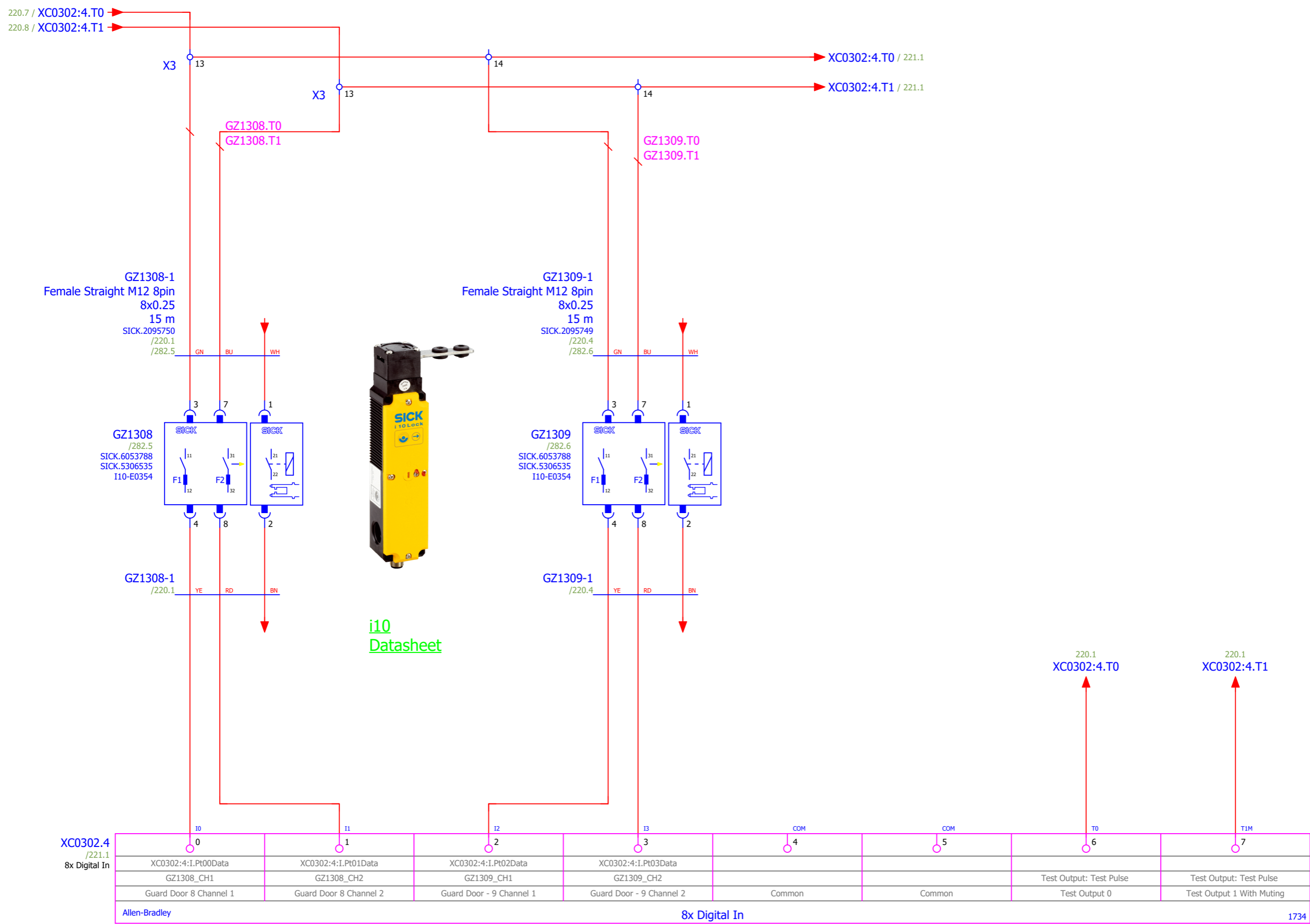

[i10 Datasheet](#)

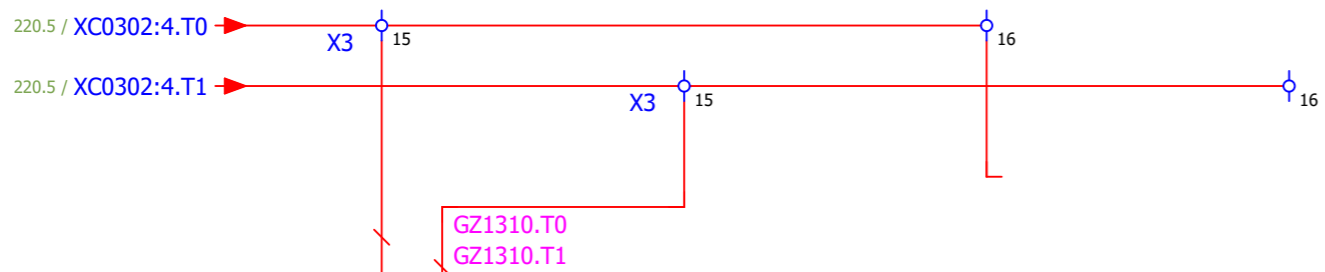

GZ1310-1
Female Straight M12 8pin
8x0.25
15 m
SICK.2095749
/221.1
/282.8

GZ1310
/282.8
SICK.6053788
SICK.5306535
I10-E0354

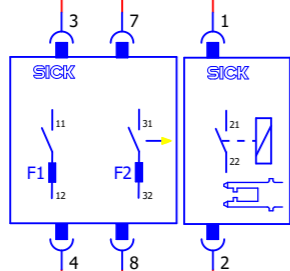

GZ1310-1
/221.1

YE RD BN



[i10 Datasheet](#)

XC0302.4
/220.1
8x Digital In

8	9	10	11	12	13	14	15
XC0302:4:I.Pt04Data	XC0302:4:I.Pt05Data	XC0302:4:I.Pt06Data	XC0302:4:I.Pt07Data	COM	COM	T2	T3M
GZ1310_CH1	GZ1310_CH2	Spare	Spare			Test Output: Test Pulse	Test Output: Test Pulse
Guard Door - 10 Channel 1	Guard Door - 10 Channel 2			Common	Common	Test Output 2	Test Output 3 With Muting
Allen-Bradley 8x Digital In							



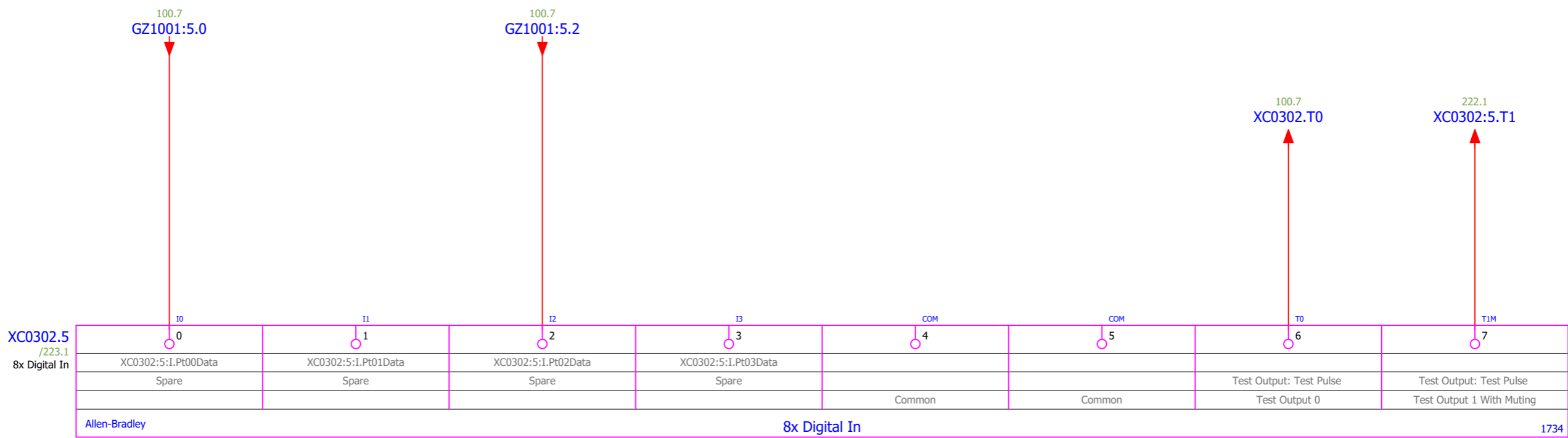
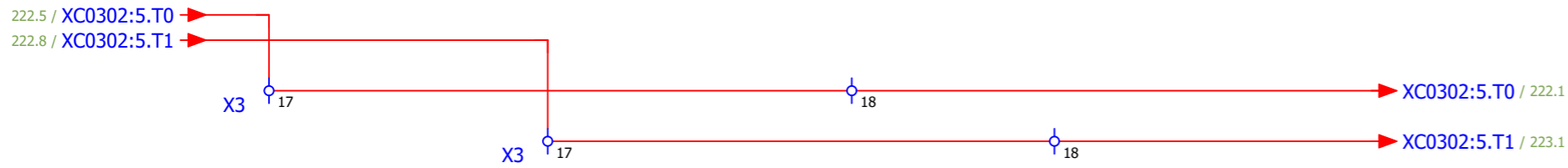

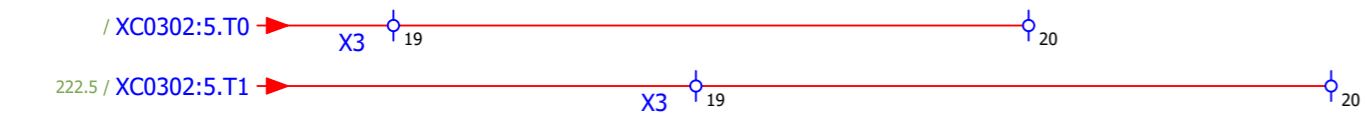

XC0302.5 /222.1 8x Digital In	14 8	15 9	16 10	17 11	COM 12	COM 13	T2 14	T3M 15
	XC0302:5:I.Pt04Data	XC0302:5:I.Pt05Data	XC0302:5:I.Pt06Data	XC0302:5:I.Pt07Data			Test Output: Test Pulse	Test Output: Test Pulse
	Spare	Spare	Spare	Spare	Common	Common	Test Output 2	Test Output 3 With Muting
	Allen-Bradley							



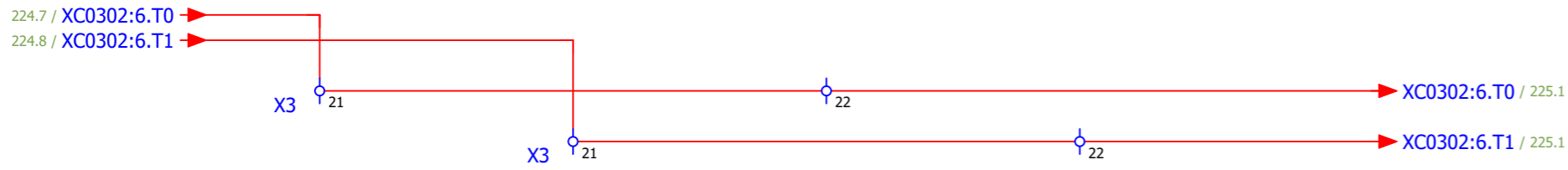

XC0302.6 /225.1 8x Digital In	10	11	12	13	COM	COM	T0	T1M		
	0	1	2	3	4	5	6	7		
	XC0302:6:I.Pt00Data	XC0302:6:I.Pt01Data	XC0302:6:I.Pt02Data	XC0302:6:I.Pt03Data			Test Output: Test Pulse	Test Output: Test Pulse		
	Spare	Spare	SPARE	SPARE	Common	Common	Test Output 0	Test Output 1 With Muting		
Allen-Bradley								8x Digital In		1734

224.1
XC0302:6.T0

224.1
XC0302:6.T1



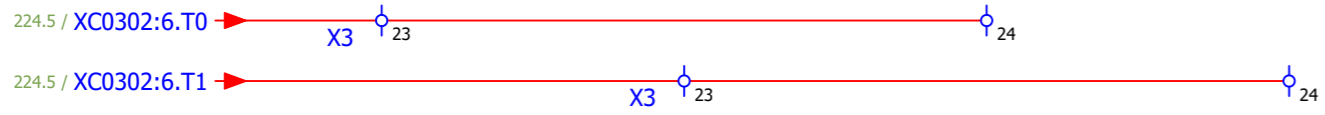

XC0302.6 /224.1 8x Digital In	I4 8	I5 9	I6 10	I7 11	COM 12	COM 13	T2 14	T3M 15
	XC0302:6:I.Pt04Data	XC0302:6:I.Pt05Data	XC0302:6:I.Pt06Data	XC0302:6:I.Pt07Data			Test Output: Test Pulse	Test Output: Test Pulse
	SPARE	SPARE	SPARE	SPARE	Common	Common	Test Output 2	Test Output 3 With Muting
	Allen-Bradley							

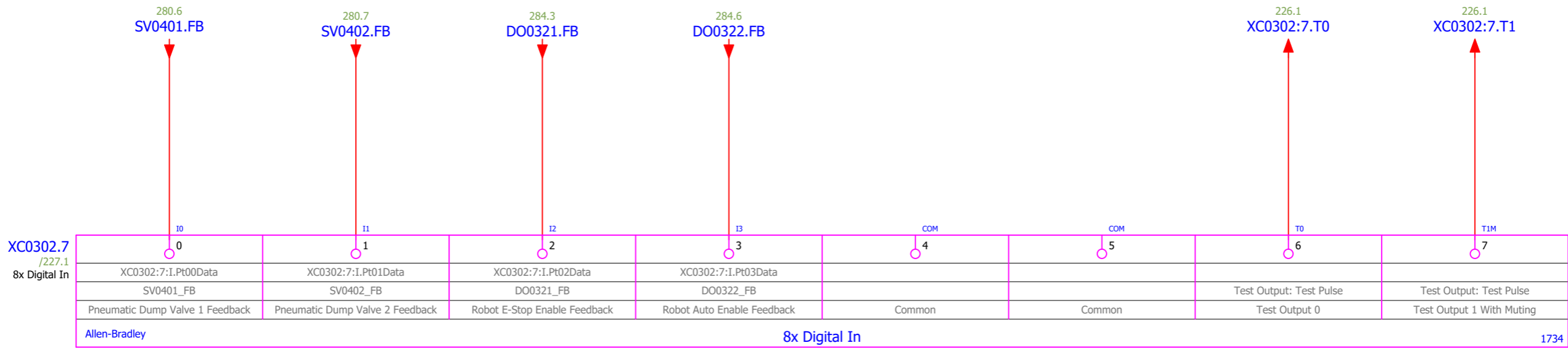
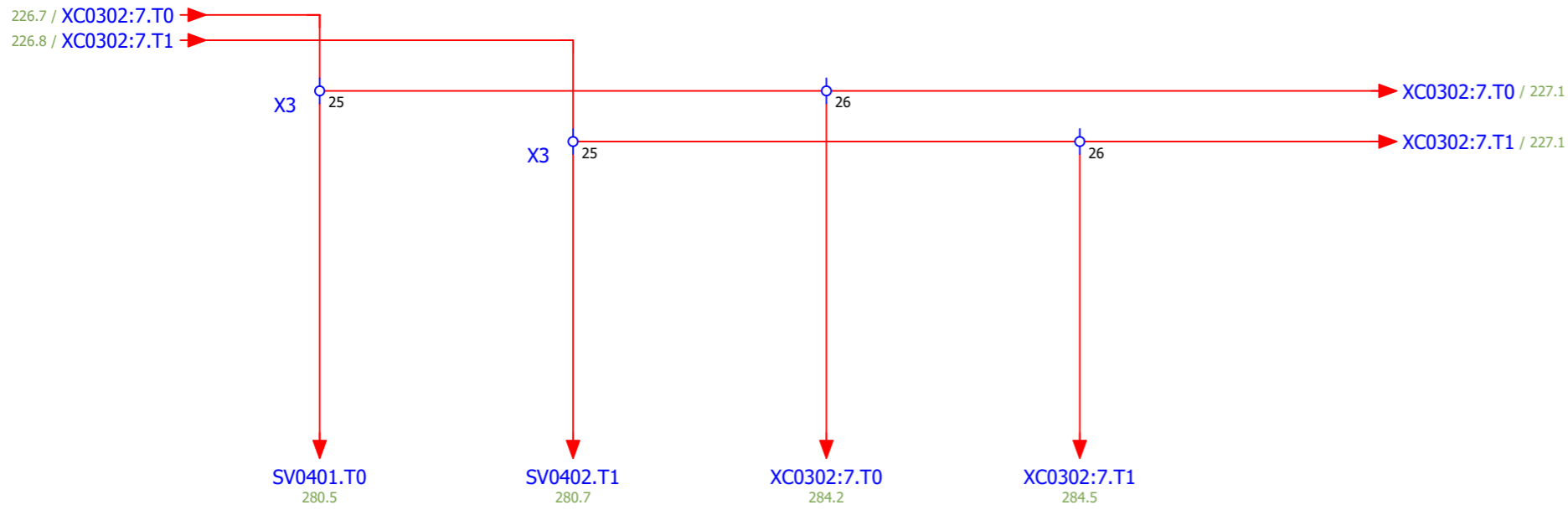

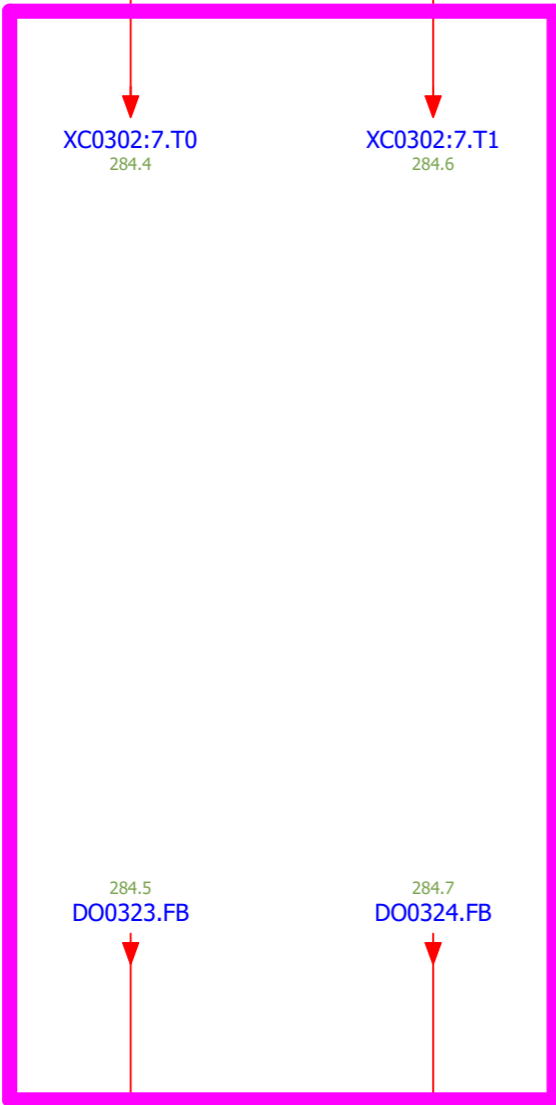
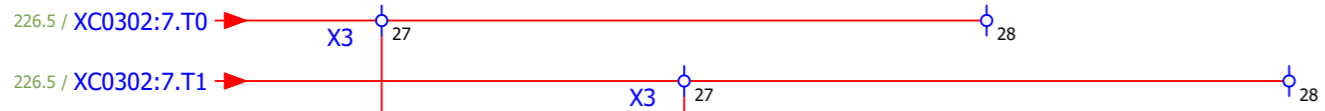

XC0302.7 /226.1 8x Digital In	I4 8	I5 9	I6 10	I7 11	COM 12	COM 13	T2 14	T3M 15
	XC0302:7:I.Pt04Data	XC0302:7:I.Pt05Data	XC0302:7:I.Pt06Data	XC0302:7:I.Pt07Data				
	DO0323_FB	DO0324_FB	Spare	SPARE			Test Output: Test Pulse	Test Output: Test Pulse
	Picking Robots E-Stop Enable Feedback	Picking Robots Auto Enable Feedback			Common	Common	Test Output 2	Test Output 3 With Muting
	Allen-Bradley							

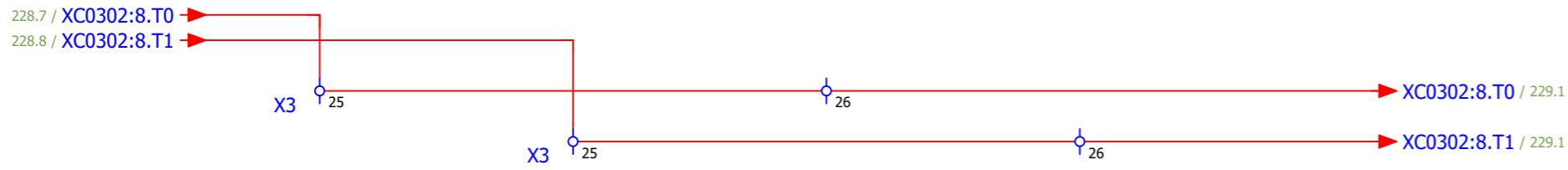

XC0302.8 /229.1 8x Digital In	I0	I1	I2	I3	COM	COM	T0	T1M		
	0	1	2	3	4	5	6	7		
	XC0302:8:I.Pt00Data	XC0302:8:I.Pt01Data	XC0302:8:I.Pt02Data	XC0302:8:I.Pt03Data			Test Output: Test Pulse	Test Output: Test Pulse		
	Spare	Spare	SPARE	SPARE	Common	Common	Test Output 0	Test Output 1 With Muting		
Allen-Bradley								8x Digital In		1734

228.1
XC0302:8.T0

228.1
XC0302:8.T1



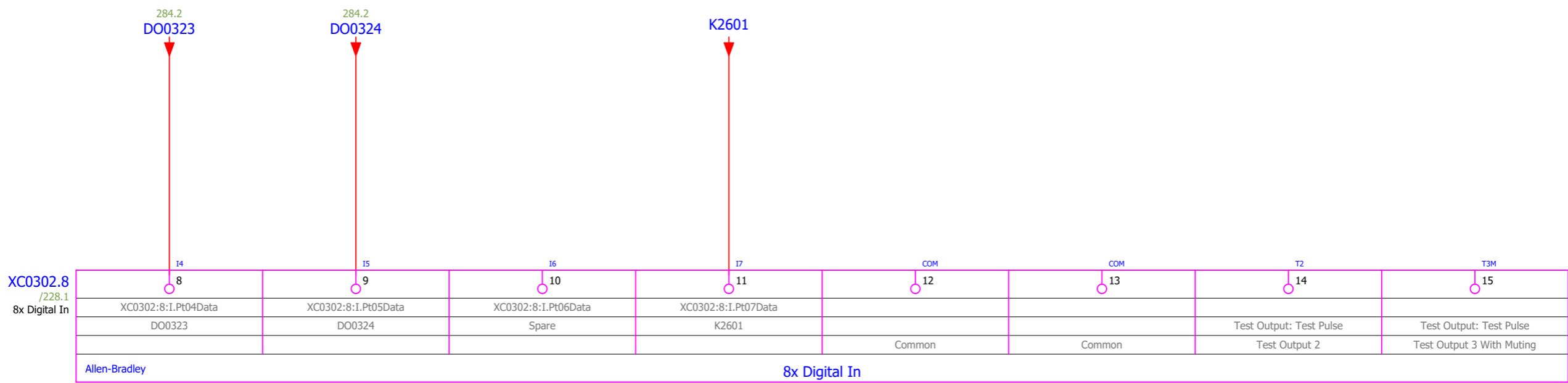
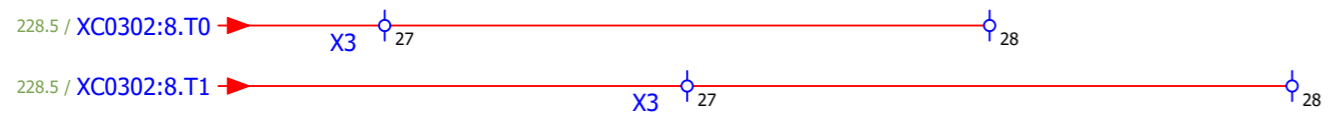

XC0302.9
/232.1
8xDigital Out

Allen-Bradley		Byte 0				8xDigital Out			1734
STO Enable 1	STO Enable 2	Pneumatic Dump Valve 1	Pneumatic Dump Valve 2	Common 4	Common 5	Common 6	Common 7		
K0322	K0323	SV0401	SV0402						
XC0302:9:O.Pt00Data	XC0302:9:O.Pt01Data	XC0302:9:O.Pt02Data	XC0302:9:O.Pt03Data						
0	1	2	3	4	5	6	7		
00	01	02	03	COM	COM	COM	COM		

0
00
K0322
109.5

1
01
K0323
109.5

2
02
SV0401
280.3

3
03
SV0402
280.4

4
COM

5
COM

6
COM

7
COM

XC0302.9
/231.1
8xDigital Out

Allen-Bradley		Byte 0		8xDigital Out			
Safety Contactor		Picking Robots E-Stop Enable	Picking Robots Auto Enable	Common 4	Common 5	Common 6	Common 7
K0320	K1301	DO0321	DO0322				
XC0302:9:O.Pt04Data	XC0302:9:O.Pt05Data	XC0302:9:O.Pt06Data	XC0302:9:O.Pt07Data				
0	1	2	3	4	5	6	7
04	05	06	07	COM	COM	COM	COM

0
04
↓
K0320
130.5

1
05
↓
K1301
281.3

2
06
↓
DO0321
284.0

3
07
↓
DO0322
284.1

4
COM

5
COM

6
COM

7
COM



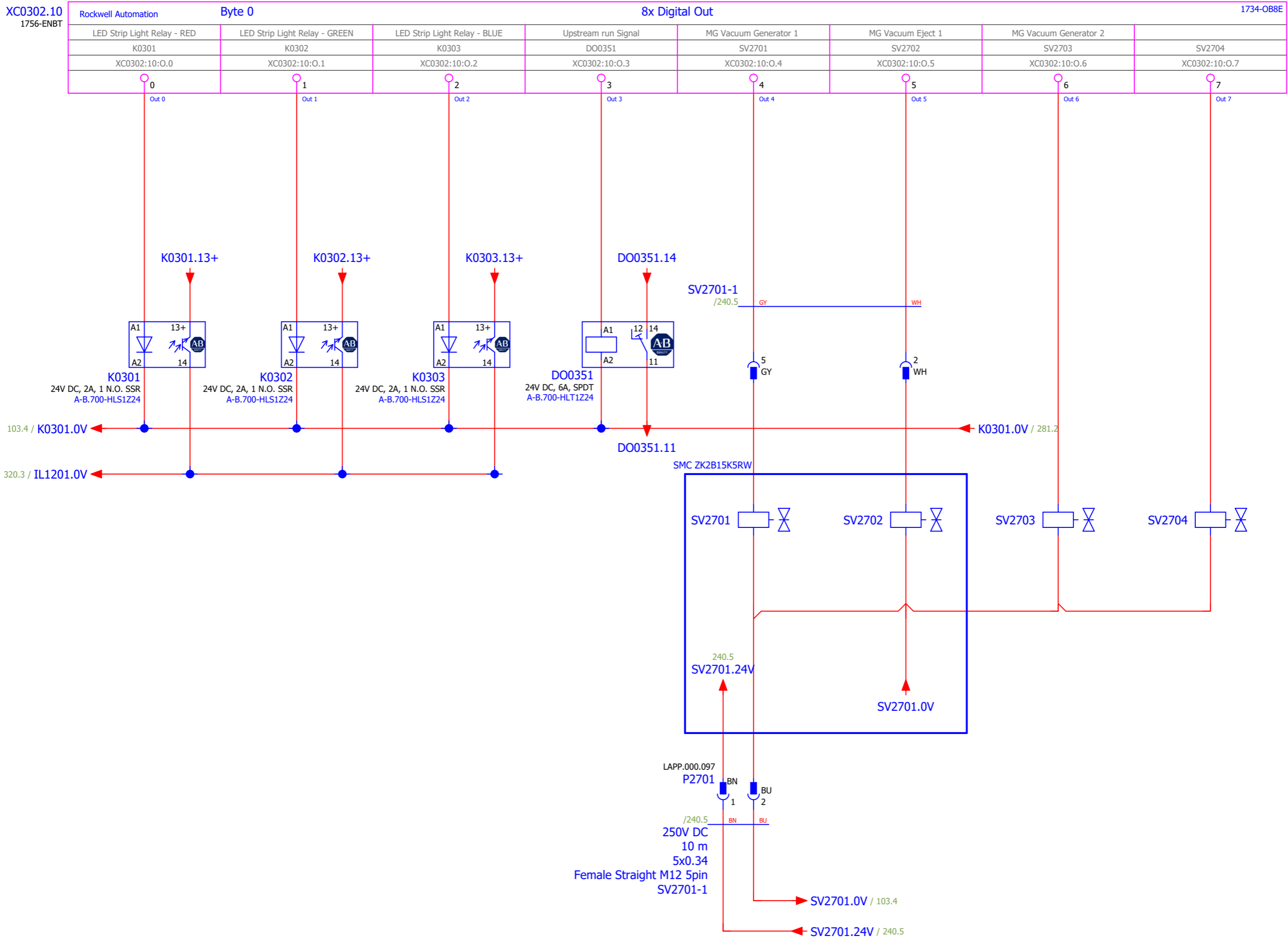

XC0302.11
1756-ENBT

Rockwell Automation		Byte 0						8x Digital Out		1734-OB8E
Picking Robot 1 Sov 1	Picking Robot 1 Sov 2	Picking Robot 1 Sov 3	Picking Robot 1 Sov 4	Picking Robot 1 Sov 5	Picking Robot 1 Sov 6	Picking Robot 1 Sov 7	Picking Robot 1 Sov 8			
SV4111	SV4112	SV4113	SV4114	SV4115	SV4116	SV4117	SV4118			
XC0302:11:O.0	XC0302:11:O.1	XC0302:11:O.2	XC0302:11:O.3	XC0302:11:O.4	XC0302:11:O.5	XC0302:11:O.6	XC0302:11:O.7			
0	1	2	3	4	5	6	7			
Out 0	Out 1	Out 2	Out 3	Out 4	Out 5	Out 6	Out 7			

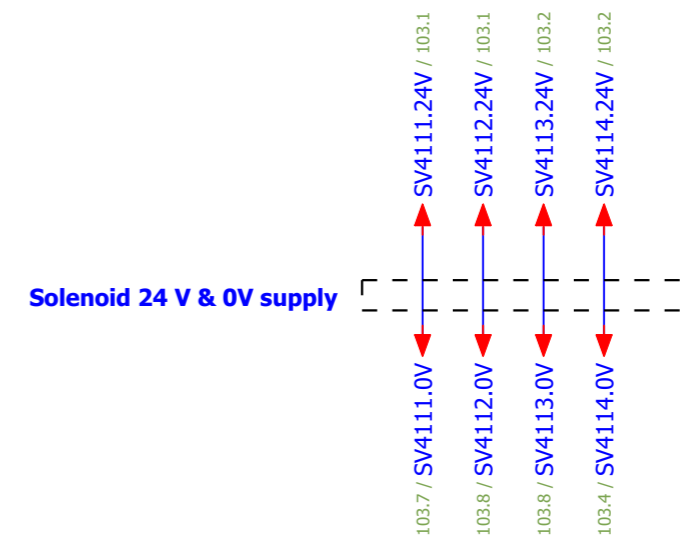
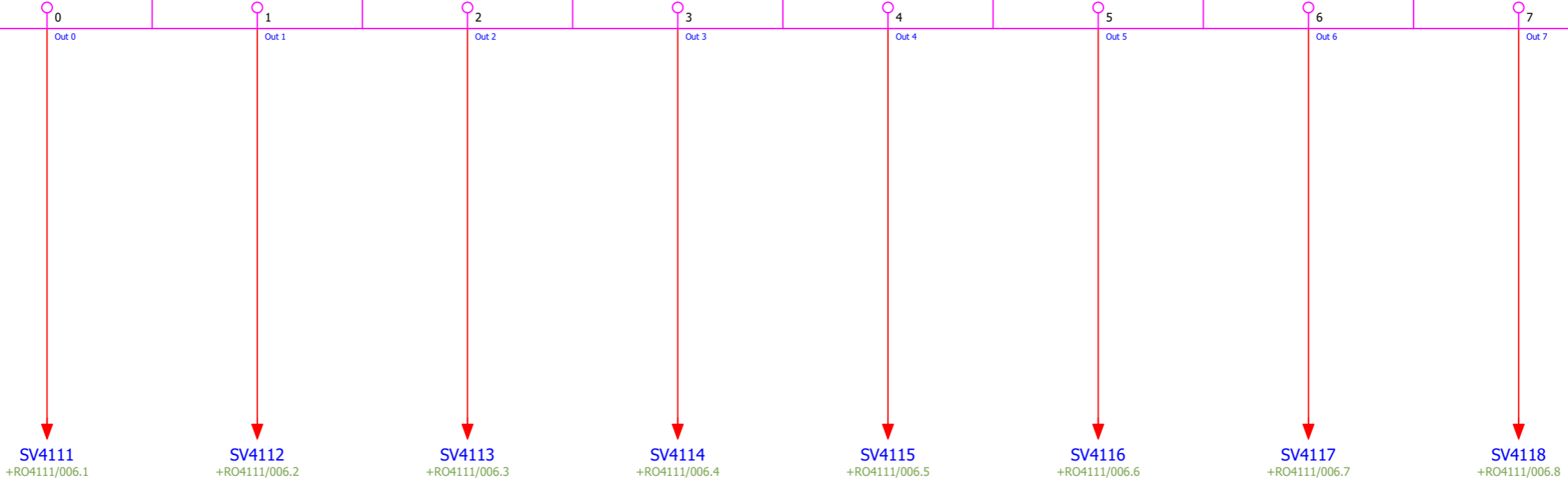

XC0302.12
1756-ENBT

Rockwell Automation		Byte 0						8x Digital Out		1734-OB8E
Picking Rob 2 Vacuum Gen. 1	Picking Rob 2 Vacuum Eject 1	Picking Rob 3 Vacuum Gen. 2	Picking Rob 1 Vacuum Eject 2	Picking Rob 1 Vacuum Gen. 3	Picking Rob 2 Vacuum Eject 3	Picking Rob 2 Vacuum Gen. 4	Picking Rob 2 Vacuum Eject 4			
SV4121	SV4122	SV4123	SV4124	SV4125	SV4126	SV4127	SV4128			
XC0302:12:O.0	XC0302:12:O.1	XC0302:12:O.2	XC0302:12:O.3	XC0302:12:O.4	XC0302:12:O.5	XC0302:12:O.6	XC0302:12:O.7			
0	1	2	3	4	5	6	7			

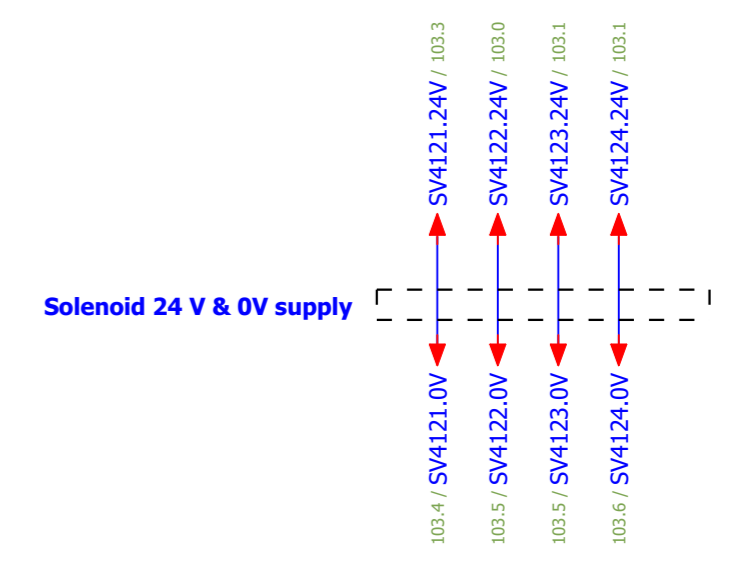
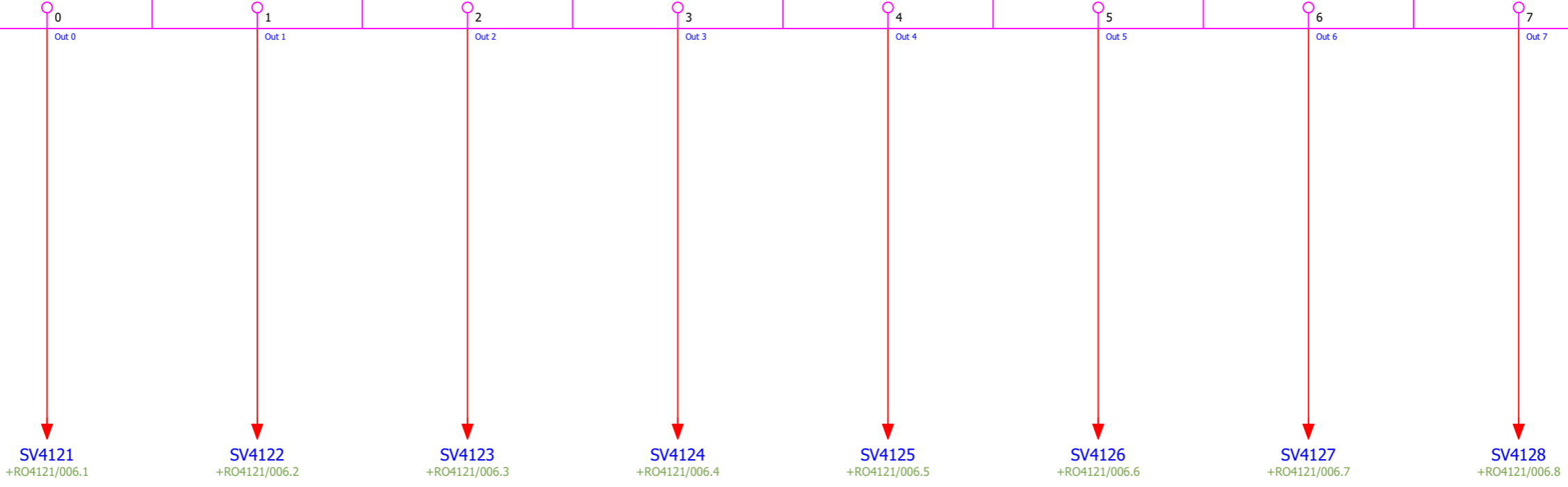

XC0302.13
1756-ENBT

Rockwell Automation		Byte 0						8x Digital Out		1734-OB8E
Picking Rob 3 Vacuum Gen. 1	Picking Rob 3 Vacuum Eject 1	Picking Rob 3 Vacuum Gen. 2	Picking Rob 3 Vacuum Eject 2	Picking Rob 3 Vacuum Gen. 3	Picking Rob 3 Vacuum Eject 3	Picking Rob 3 Vacuum Gen. 4	Picking Rob 3 Vacuum Eject 4			
SV4131	SV4132	SV4133	SV4134	SV4135	SV4136	SV4137	SV4138			
XC0302:13:O.0	XC0302:13:O.1	XC0302:13:O.2	XC0302:13:O.3	XC0302:13:O.4	XC0302:13:O.5	XC0302:13:O.6	XC0302:13:O.7			
0	1	2	3	4	5	6	7			

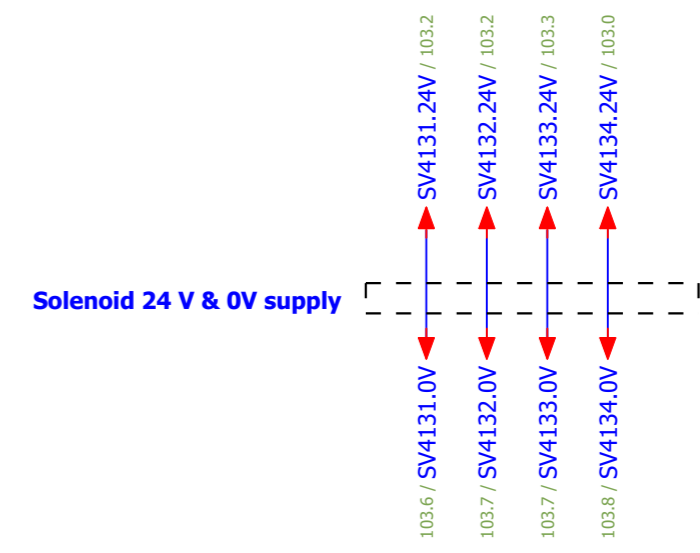
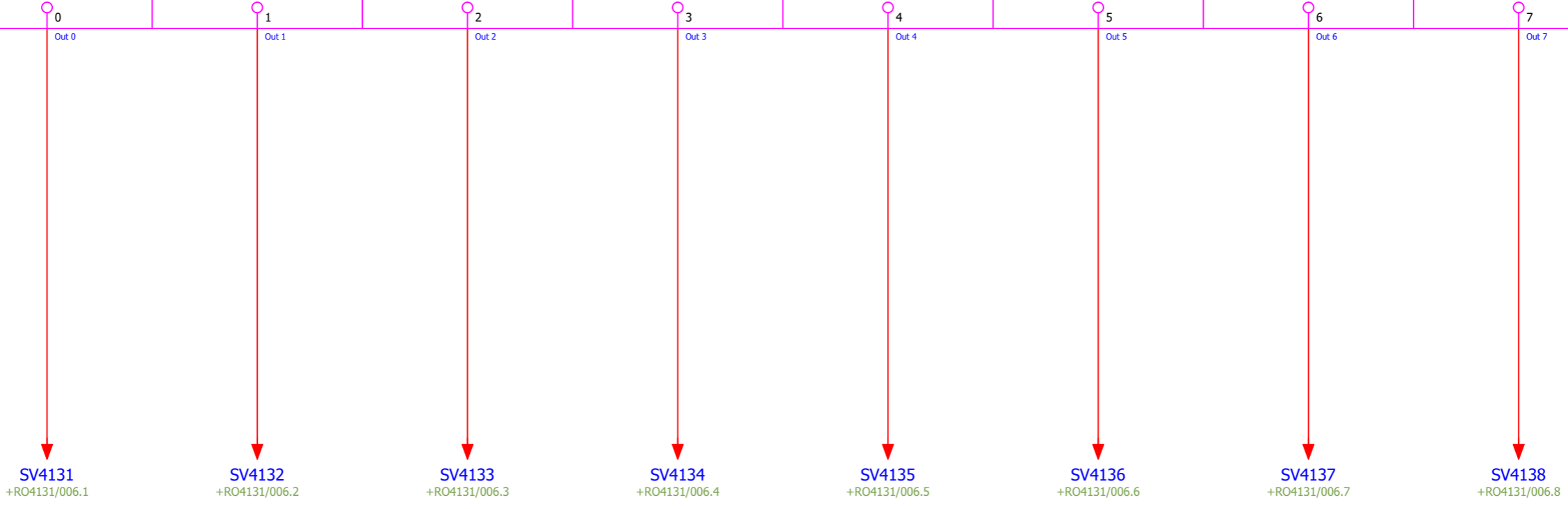

XC0302.14
1756-ENBT

Rockwell Automation		Byte 0					8x Digital Out		1734-OB8E
SPARE	K2900	XC4011:I/O.4	XC4011:I/O.5	XC4011:I/O.6	XC4011:I/O.7	Spare	Spare		
XC0302:14:O.0	XC0302:14:O.1	XC0302:14:O.2	XC0302:14:O.3	XC0302:14:O.4	XC0302:14:O.5	XC0302:14:O.6	XC0302:14:O.7		
0	1	2	3	4	5	6	7		
Out 0	Out 1	Out 2	Out 3	Out 4	Out 5	Out 6	Out 7		

K2900
320.3

XC04011:I/O.4
305.2

XC04011:I/O.5
312.1

XC04011:I/O.6
305.3

XC04011:I/O.7
312.2



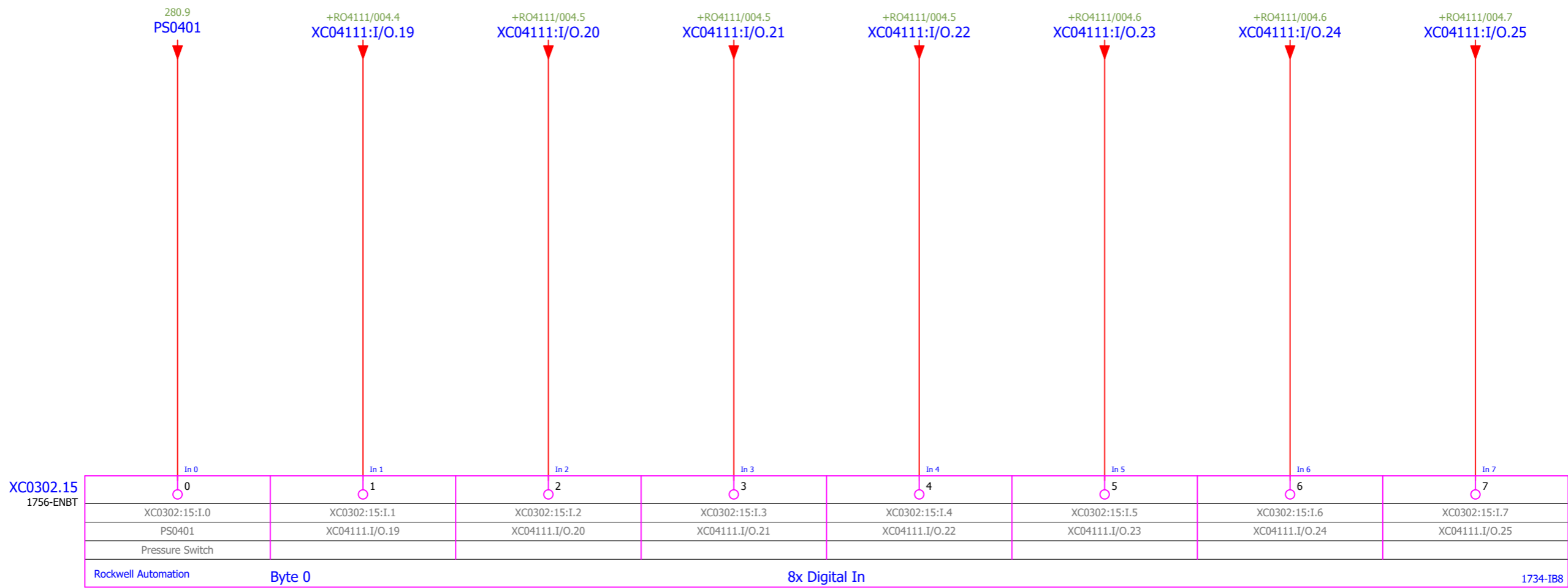

0 1 2 3 4 5 6 7 8 9

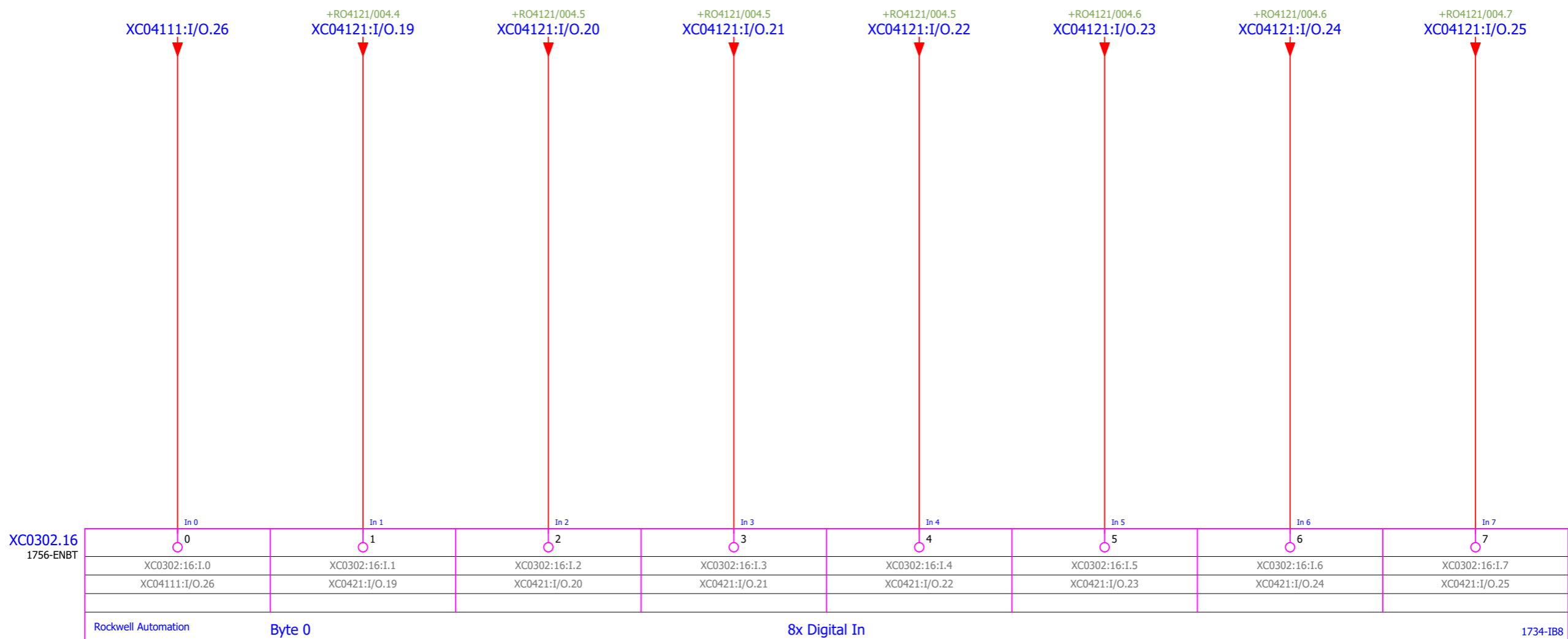

0 1 2 3 4 5 6 7 8 9

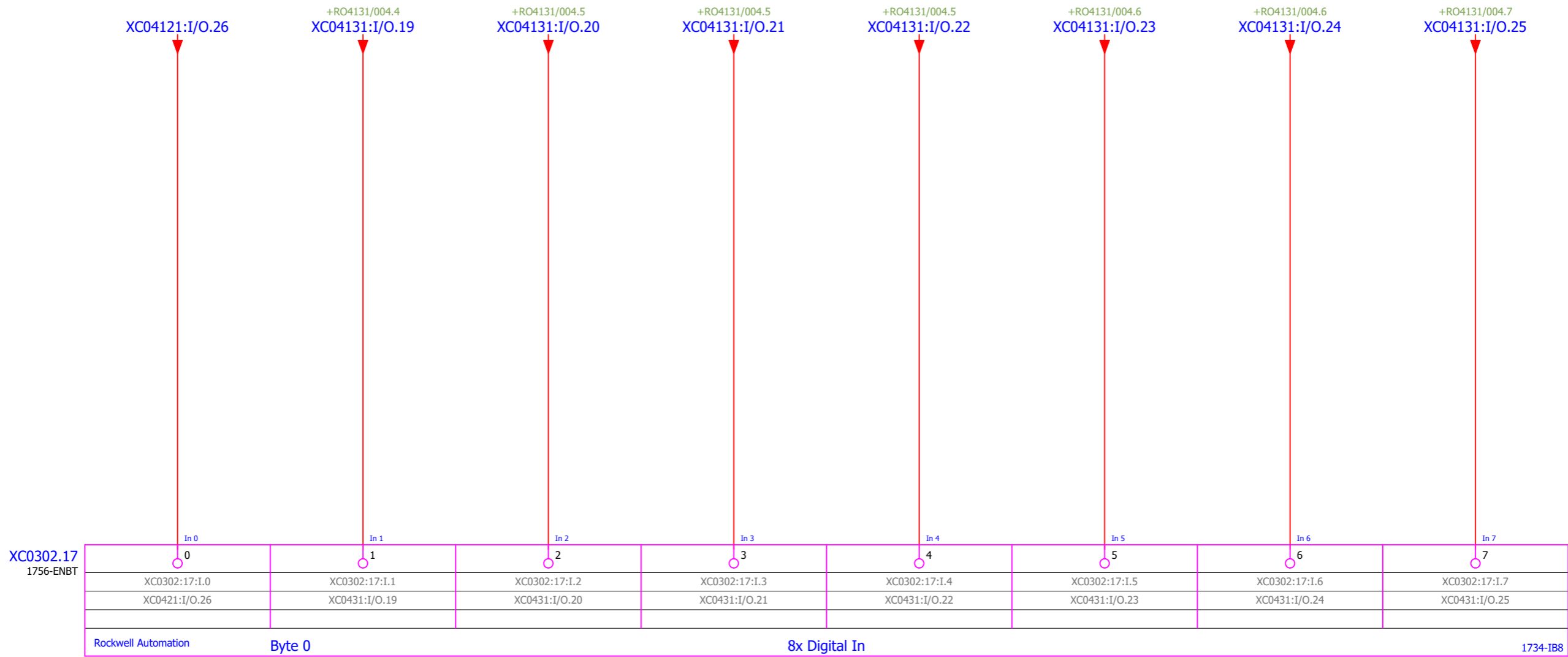

0 1 2 3 4 5 6 7 8 9

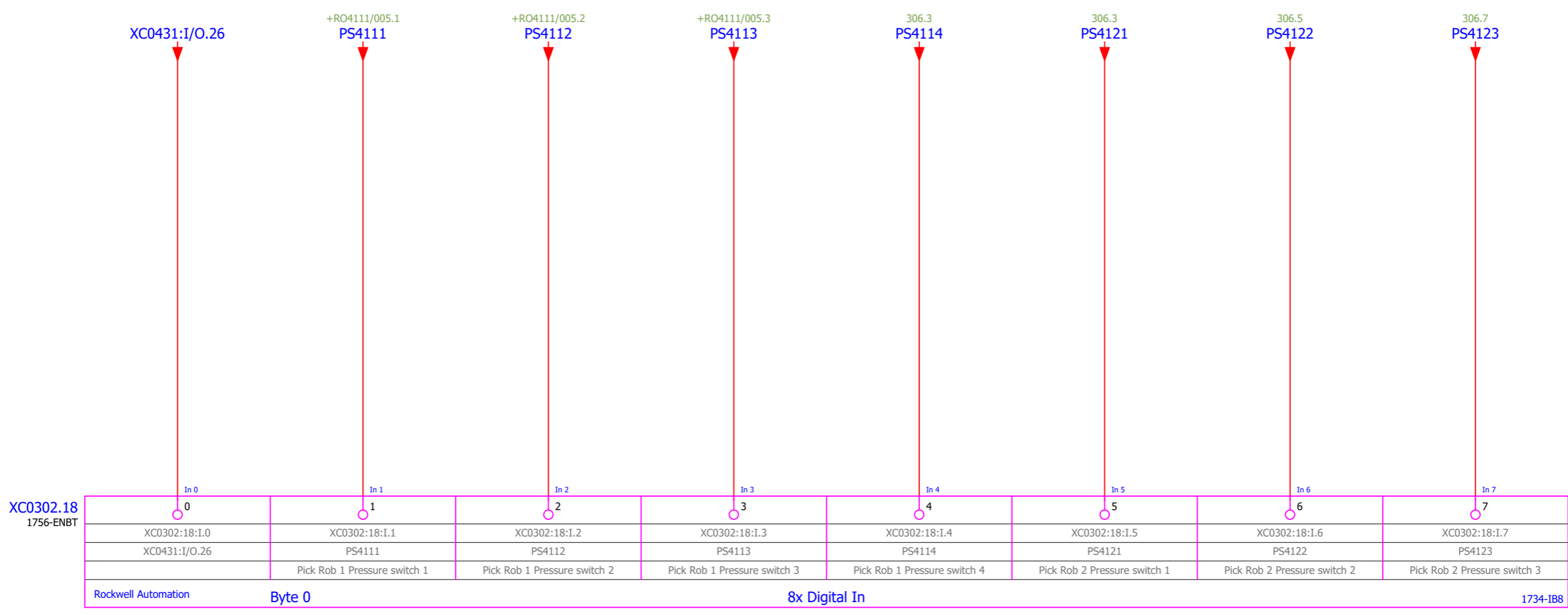

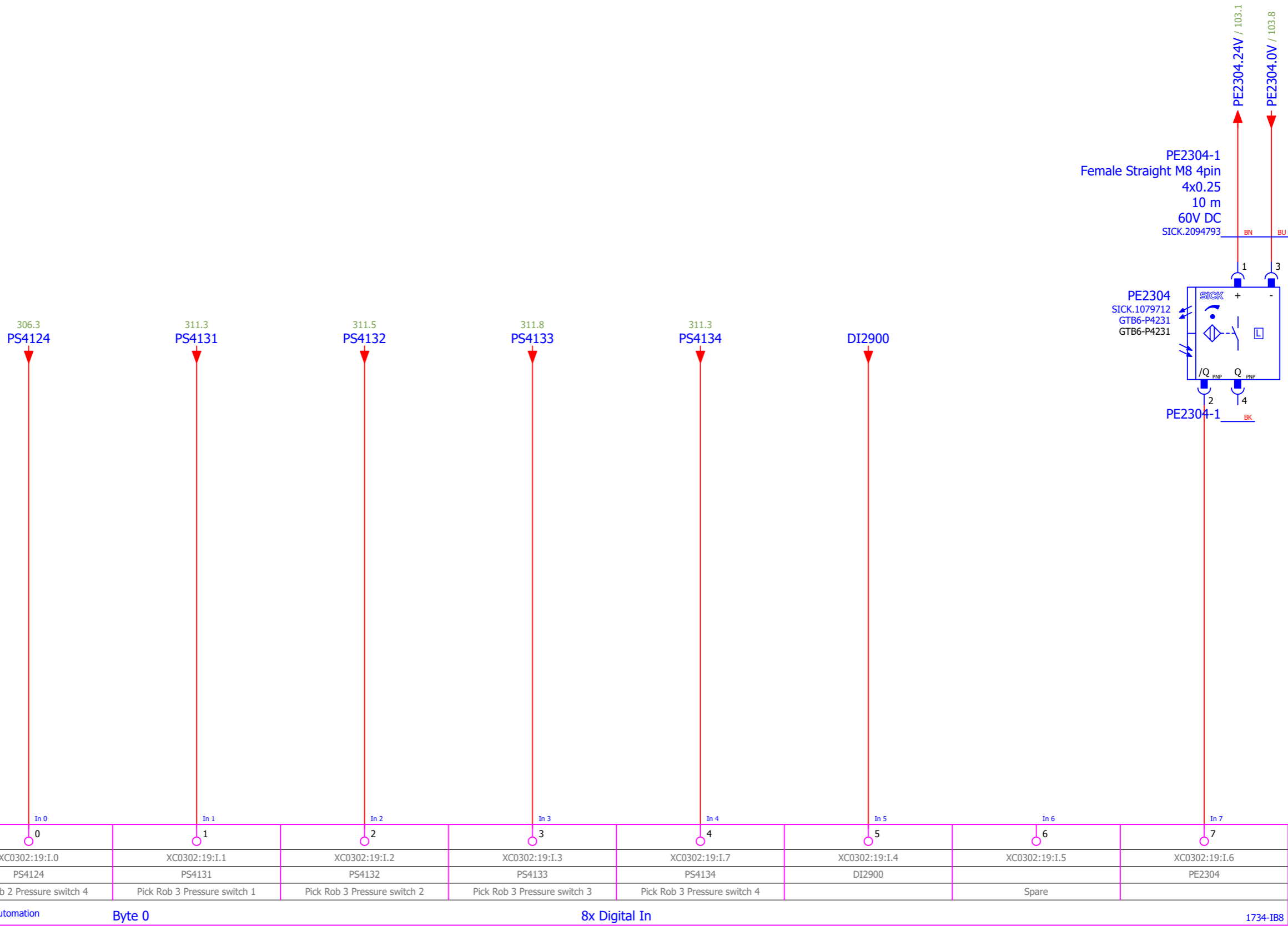

XC0302.19
1756-ENBT

In 0	In 1	In 2	In 3	In 4	In 5	In 6	In 7	
0	1	2	3	4	5	6	7	
XC0302:19:I.0	XC0302:19:I.1	XC0302:19:I.2	XC0302:19:I.3	XC0302:19:I.7	XC0302:19:I.4	XC0302:19:I.5	XC0302:19:I.6	
PS4124	PS4131	PS4132	PS4133	PS4134	DI2900	Spare	PE2304	
Pick Rob 2 Pressure switch 4	Pick Rob 3 Pressure switch 1	Pick Rob 3 Pressure switch 2	Pick Rob 3 Pressure switch 3	Pick Rob 3 Pressure switch 4				
Rockwell Automation							Byte 0	8x Digital In
								1734-IB8



0 1 2 3 4 5 6 7 8 9

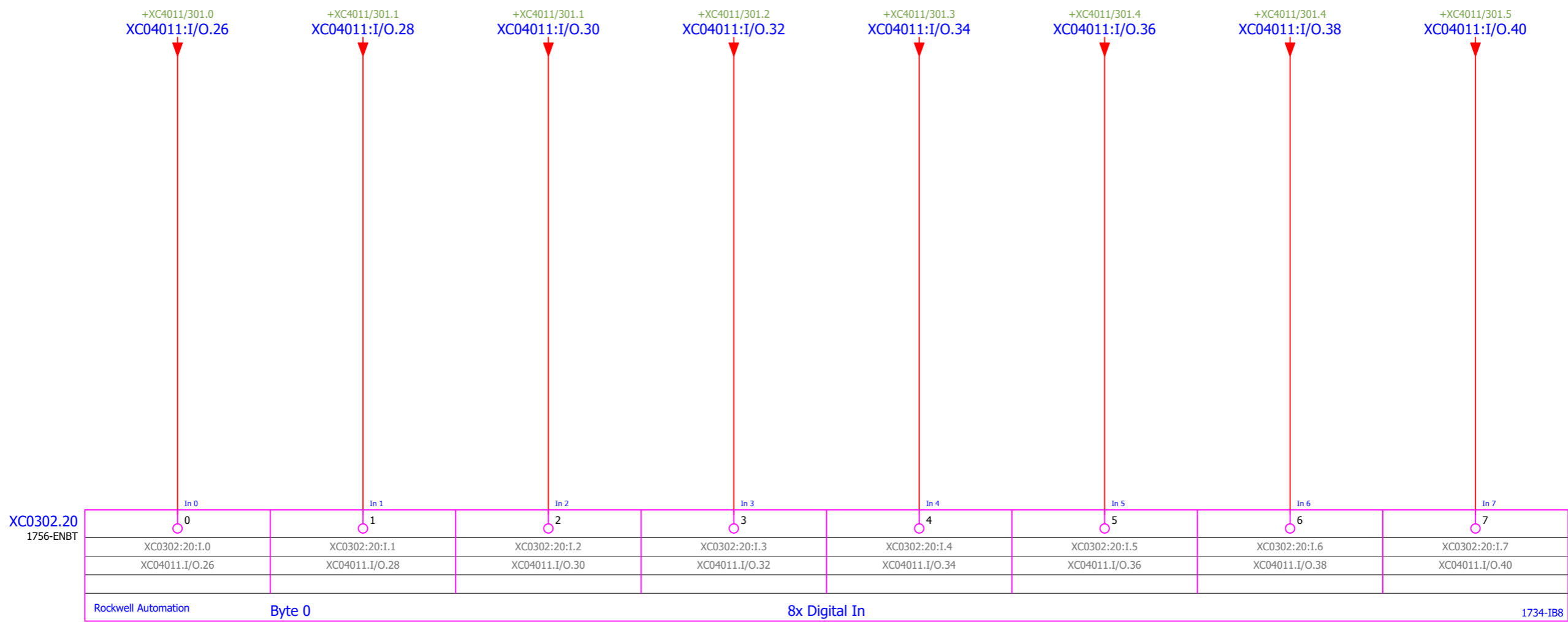

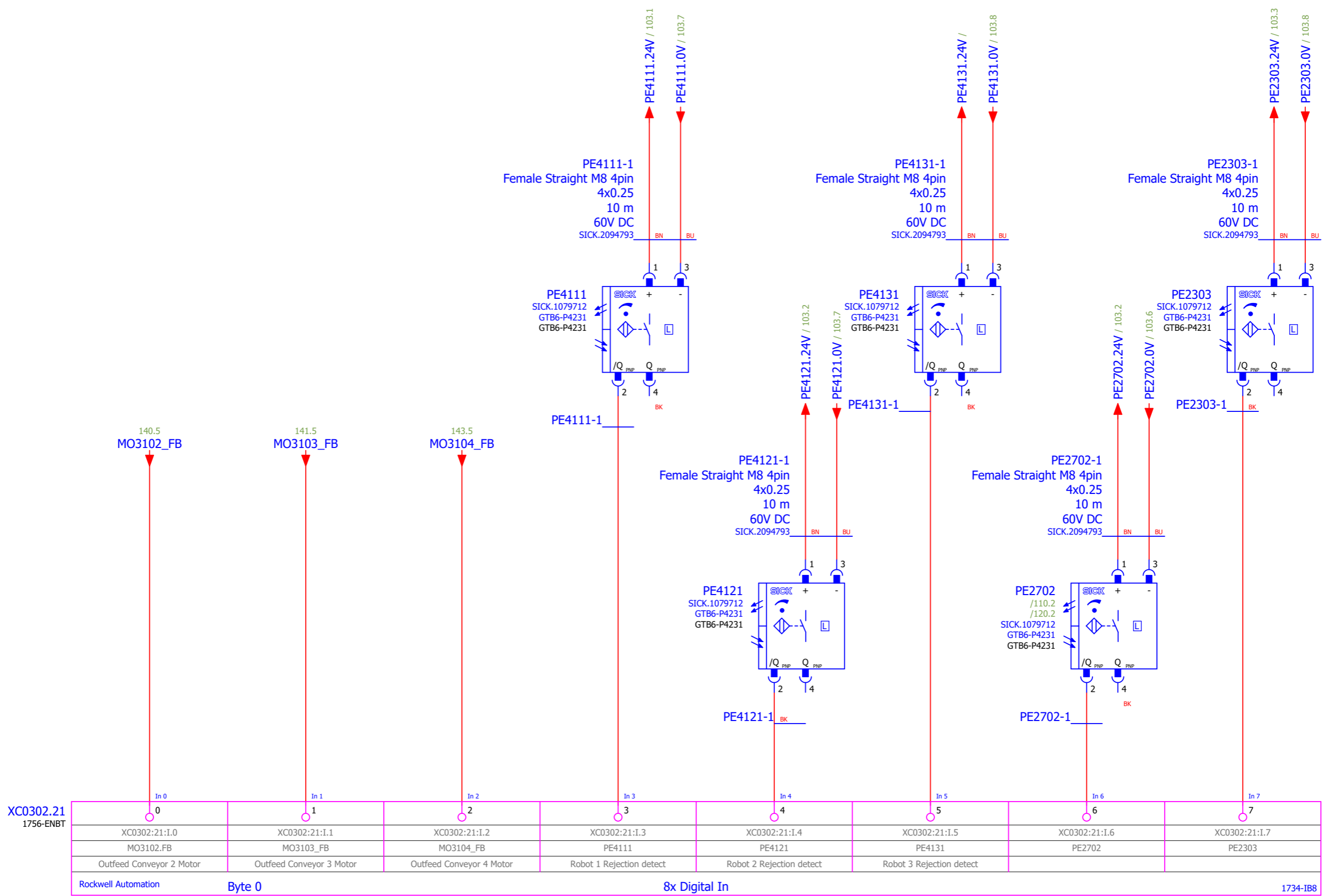

XC0302.21 1756-ENBT	In 0	In 1	In 2	In 3	In 4	In 5	In 6	In 7			
	0	1	2	3	4	5	6	7			
	XC0302:21:I.0	XC0302:21:I.1	XC0302:21:I.2	XC0302:21:I.3	XC0302:21:I.4	XC0302:21:I.5	XC0302:21:I.6	XC0302:21:I.7			
	MO3102_FB	MO3103_FB	MO3104_FB	PE4111	PE4121	PE4131	PE2702	PE2303			
Outfeed Conveyor 2 Motor		Outfeed Conveyor 3 Motor		Outfeed Conveyor 4 Motor		Robot 1 Rejection detect		Robot 2 Rejection detect		Robot 3 Rejection detect	
Rockwell Automation		Byte 0		8x Digital In						1734-IB8	



XC0302.22
1756-ENBT

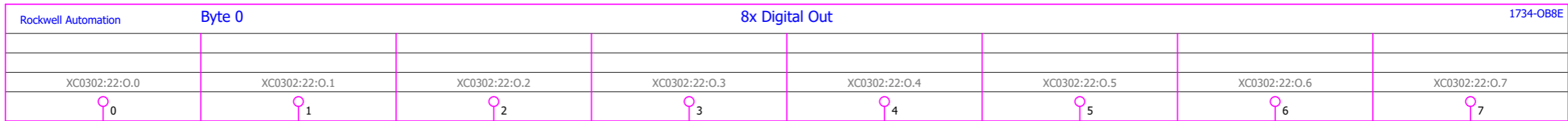

XC0302.22.00

XC0302.22.01
312.1

XC0302.22.02
312.1

XC0302.22.03
312.2

XC0302.22.04
312.3

XC0302.22.05
312.3

XC0302.22.06
312.4

XC0302.22.07
312.5



XC0302.23
1756-ENBT

Rockwell Automation	Byte 0							8x Digital Out	1734-OB8E
	Outfeed Conveyor 2 Motor	Outfeed Conveyor 3 motor	Outfeed Conveyor 4 Motor						
DO0305	MO3102	MO3103	MO3104						
XC0302:23:O.0	XC0302:23:O.1	XC0302:23:O.2	XC0302:23:O.3	XC0302:23:O.4	XC0302:23:O.5	XC0302:23:O.6	XC0302:23:O.7		
0	1	2	3	4	5	6	7		

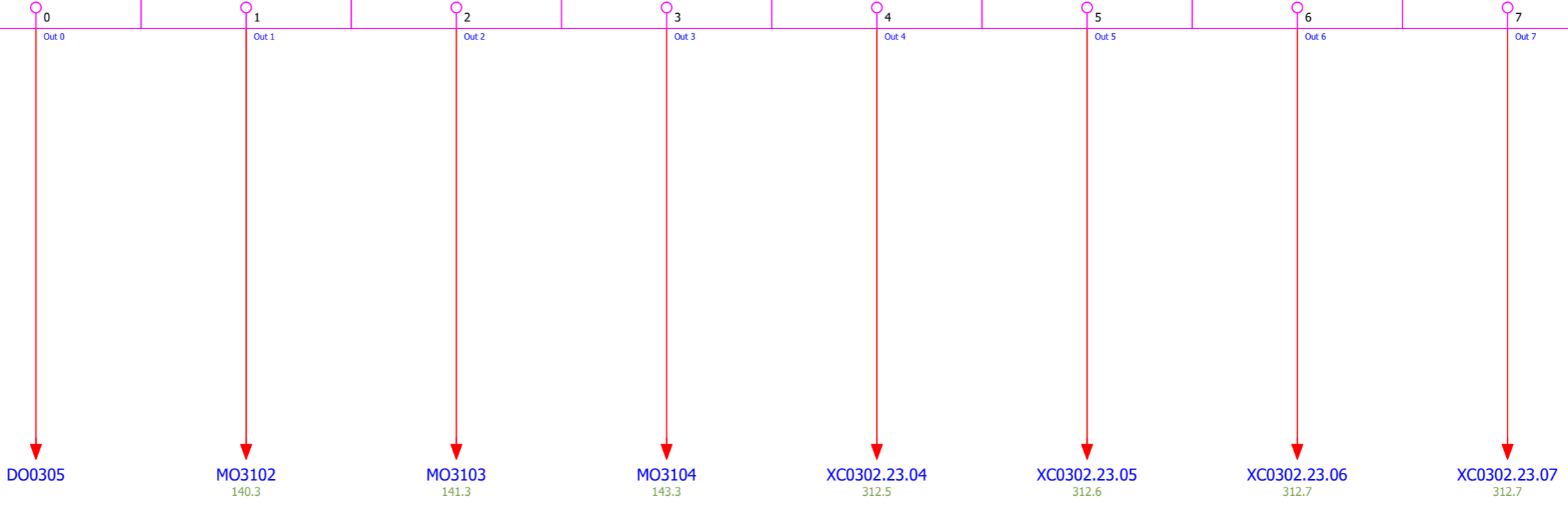

XC0302.24
1756-ENBT

Rockwell Automation		Byte 0		8x Digital Out				1734-OB8E
XC0302:24:O.0	XC0302:24:O.1	XC0302:24:O.2	XC0302:24:O.3	XC0302:24:O.4	XC0302:24:O.5	XC0302:24:O.6	XC0302:24:O.7	
0	1	2	3	4	5	6	7	
Out 0	Out 1	Out 2	Out 3	Out 4	Out 5	Out 6	Out 7	

XC04121:I/O.4
309.3

XC04121:I/O.5
309.5

XC04121:I/O.6
309.8

XC04121:I/O.7
309.3

XC04131:I/O.4
311.3

XC04131:I/O.5
311.5

XC04131:I/O.6
311.8

XC04131:I/O.7
311.3

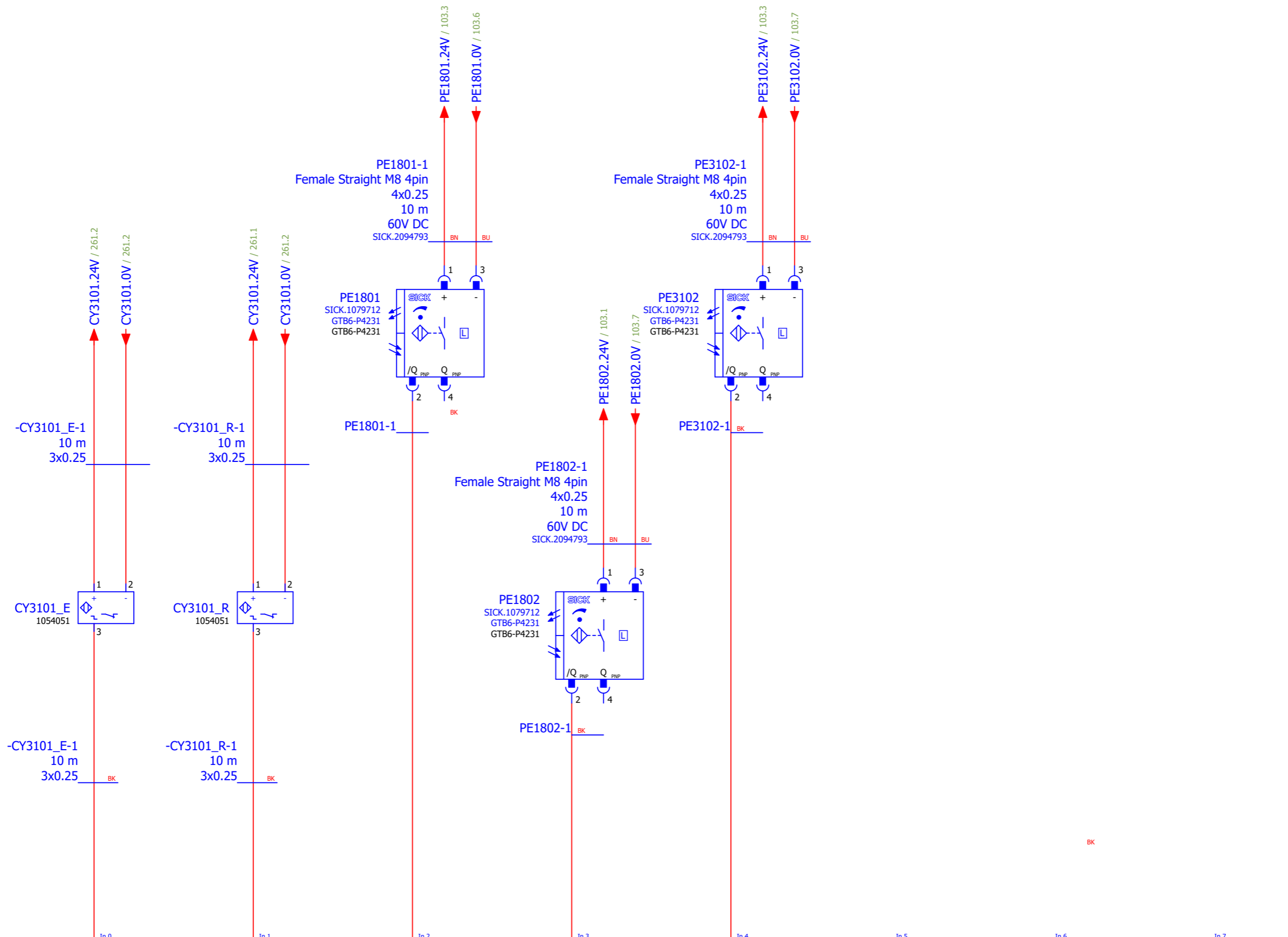

XC0302.25 1756-ENBT	In 0	In 1	In 2	In 3	In 4	In 5	In 6	In 7
	0	1	2	3	4	5	6	7
	XC0302:25:I.0	XC0302:25:I.1	XC0302:25:I.2	XC0302:25:I.3	XC0302:25:I.4	XC0302:25:I.5	XC0302:25:I.6	XC0302:25:I.7
	CY3101_E	CY3101_R	MO3104_FB	PE4111	PE4121	PE4131	PE2702	PE2303
Rockwell Automation		Byte 0		8x Digital In				1734-IB8



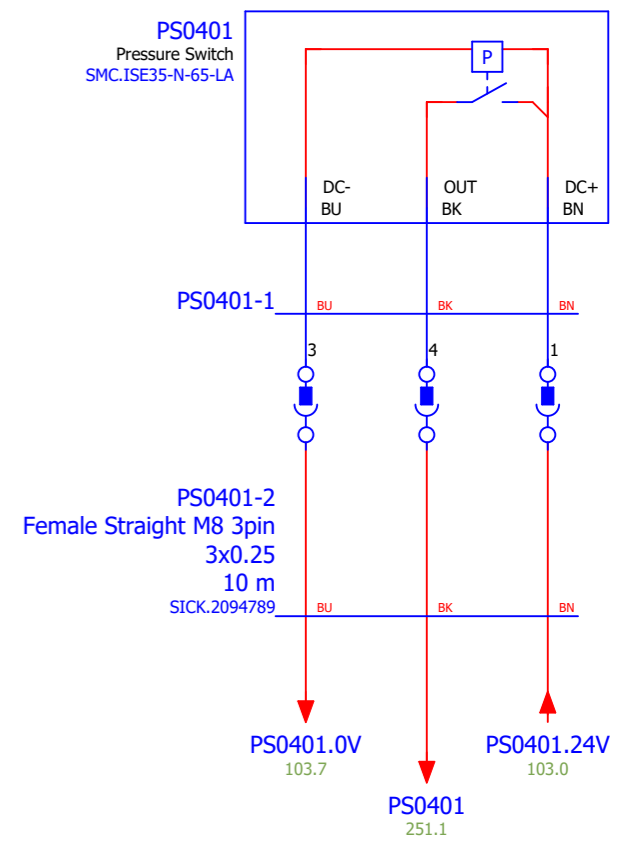
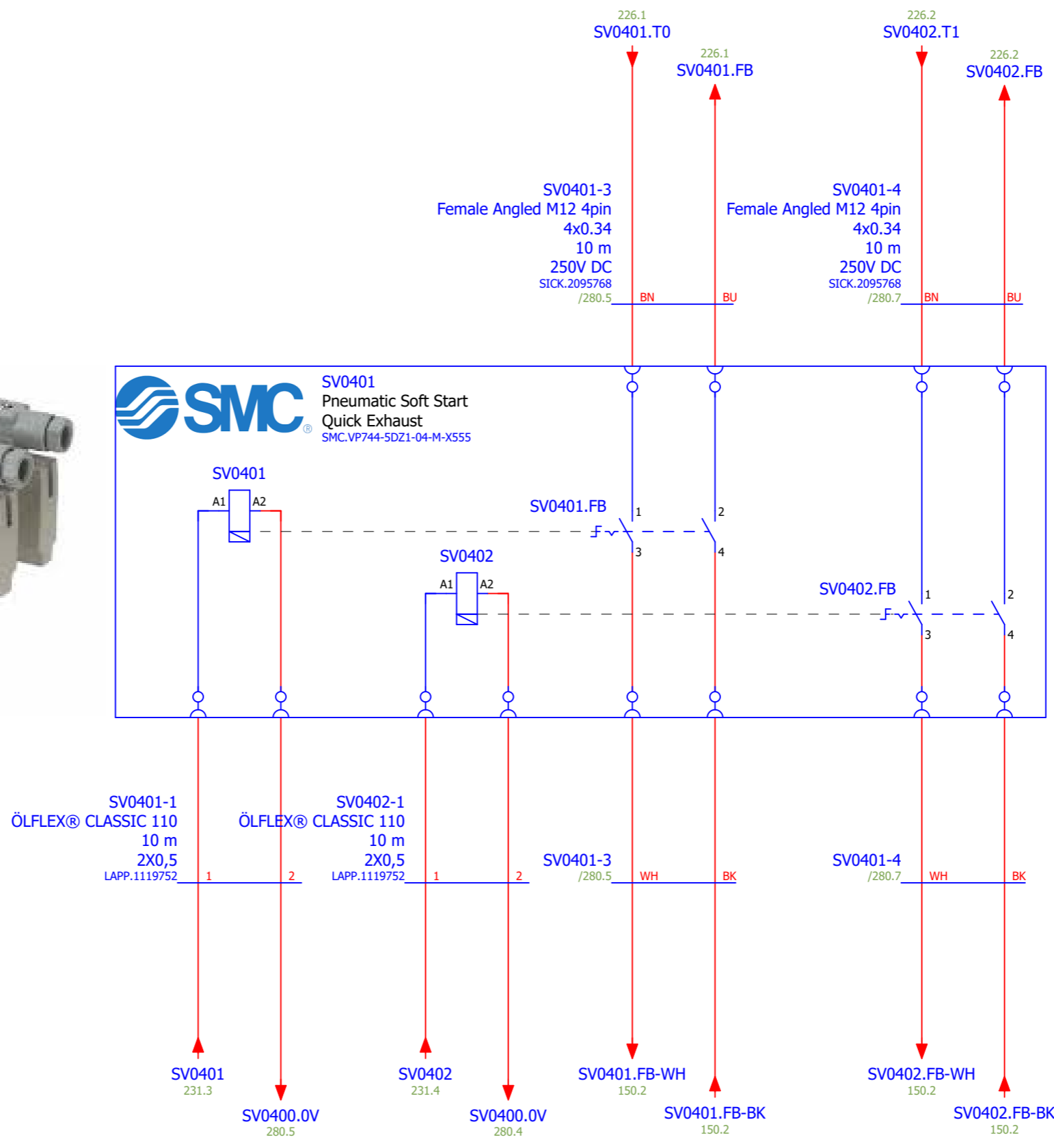
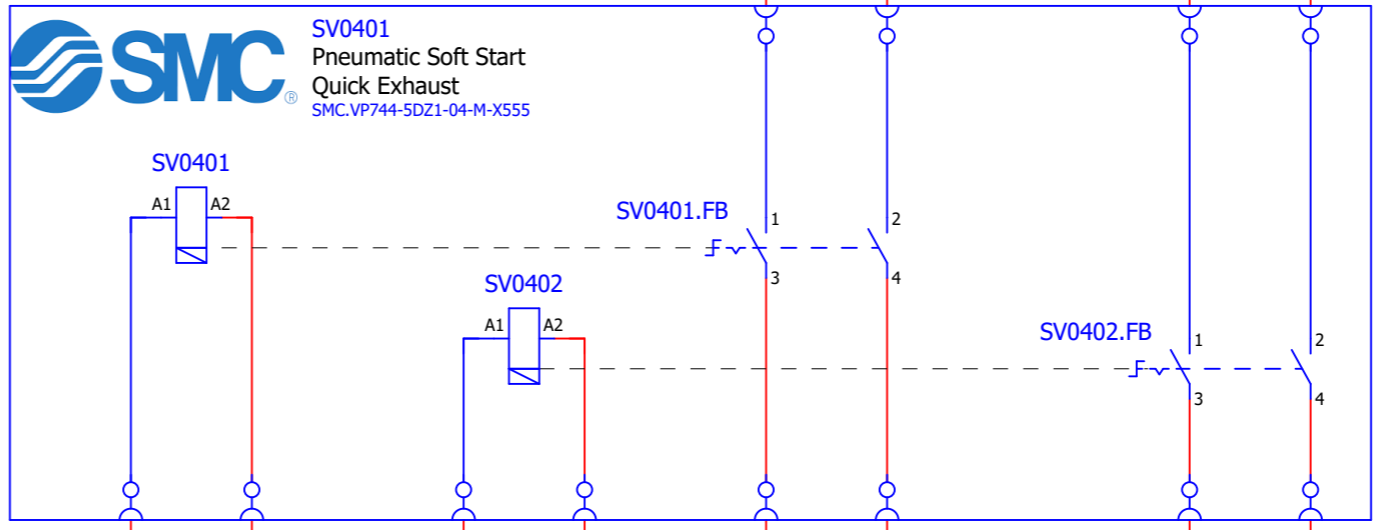

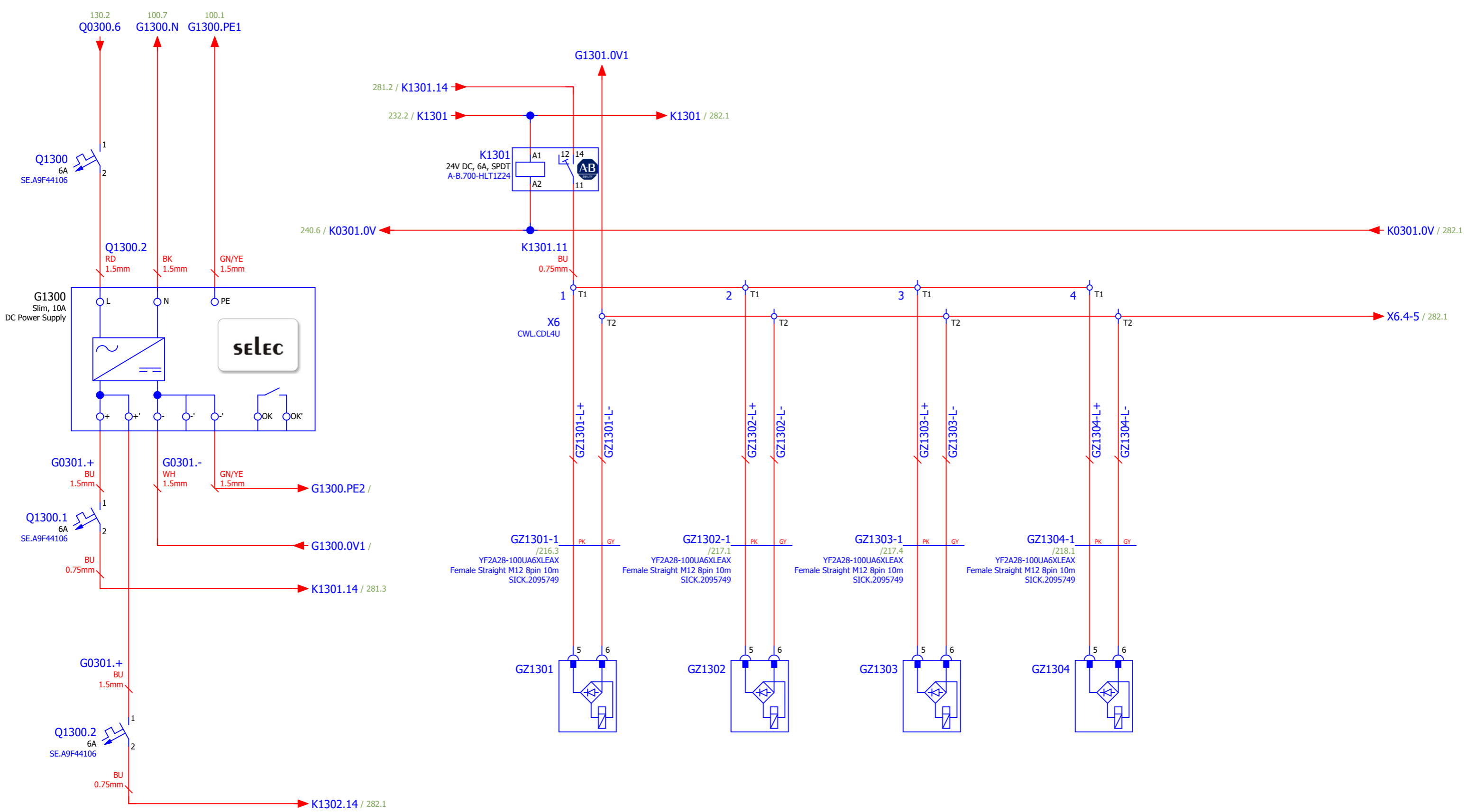

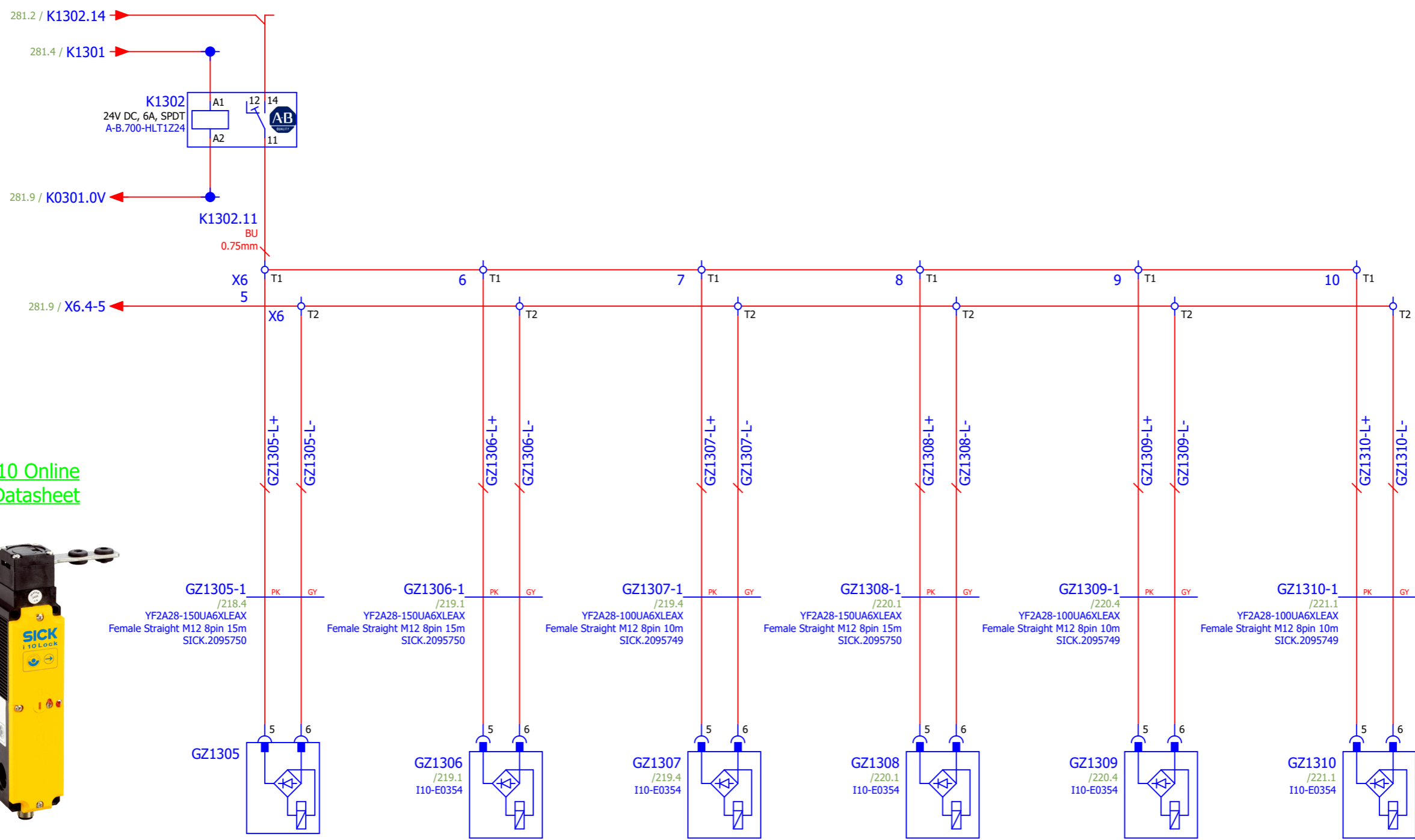

[i10 Online Datasheet](#)



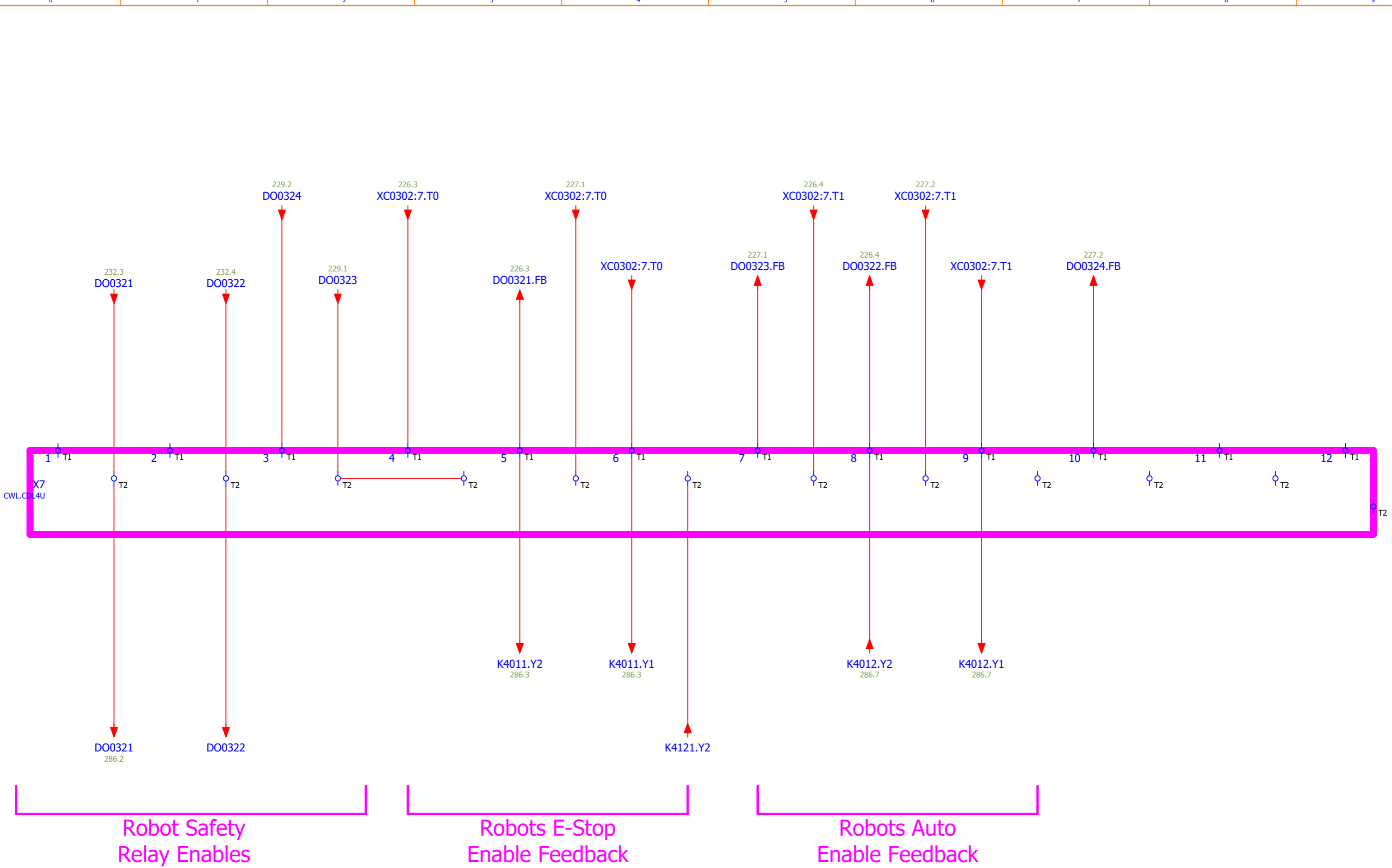

Robot Safety
Relay Enables

Robots E-Stop
Enable Feedback

Robots Auto
Enable Feedback



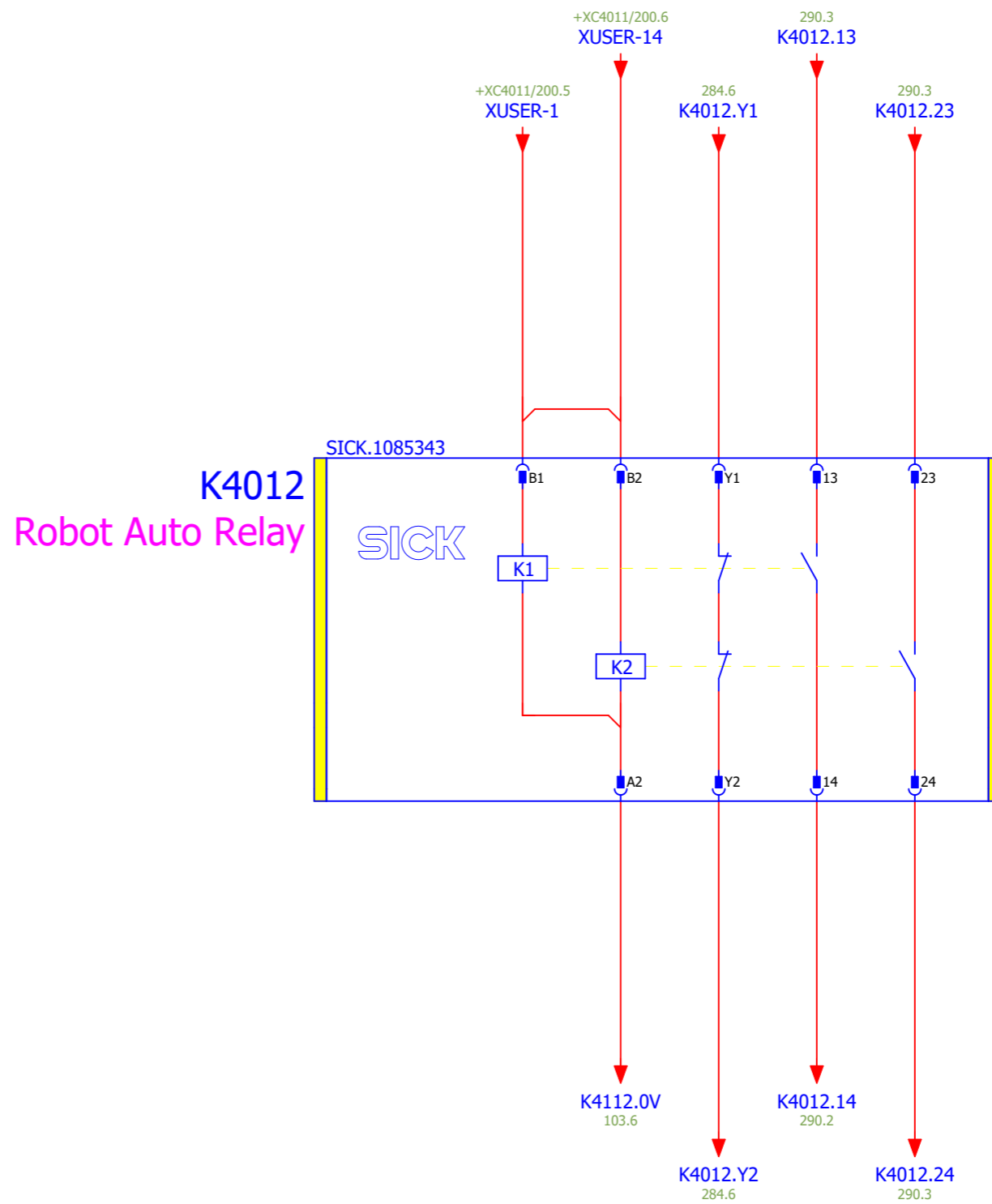
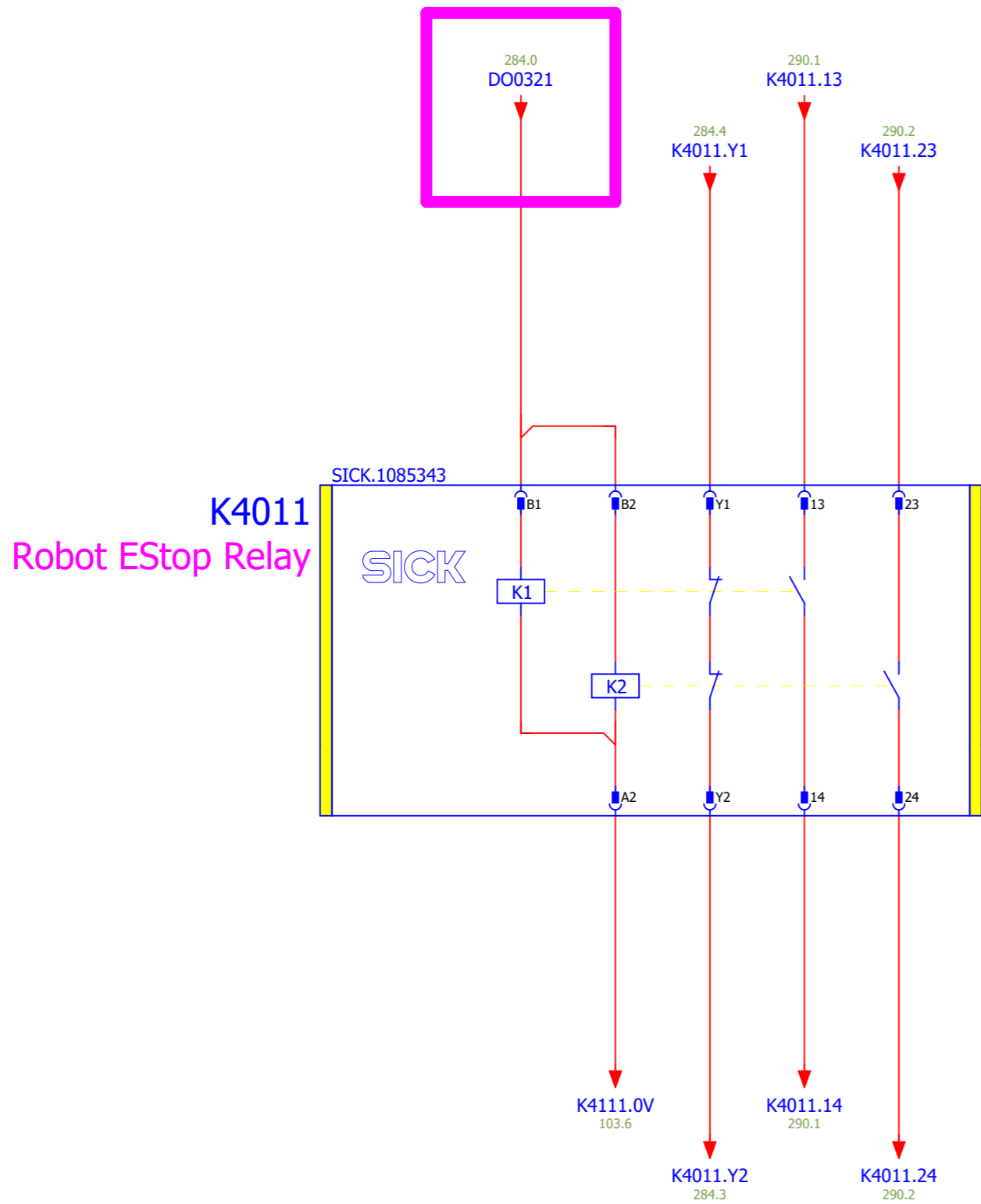

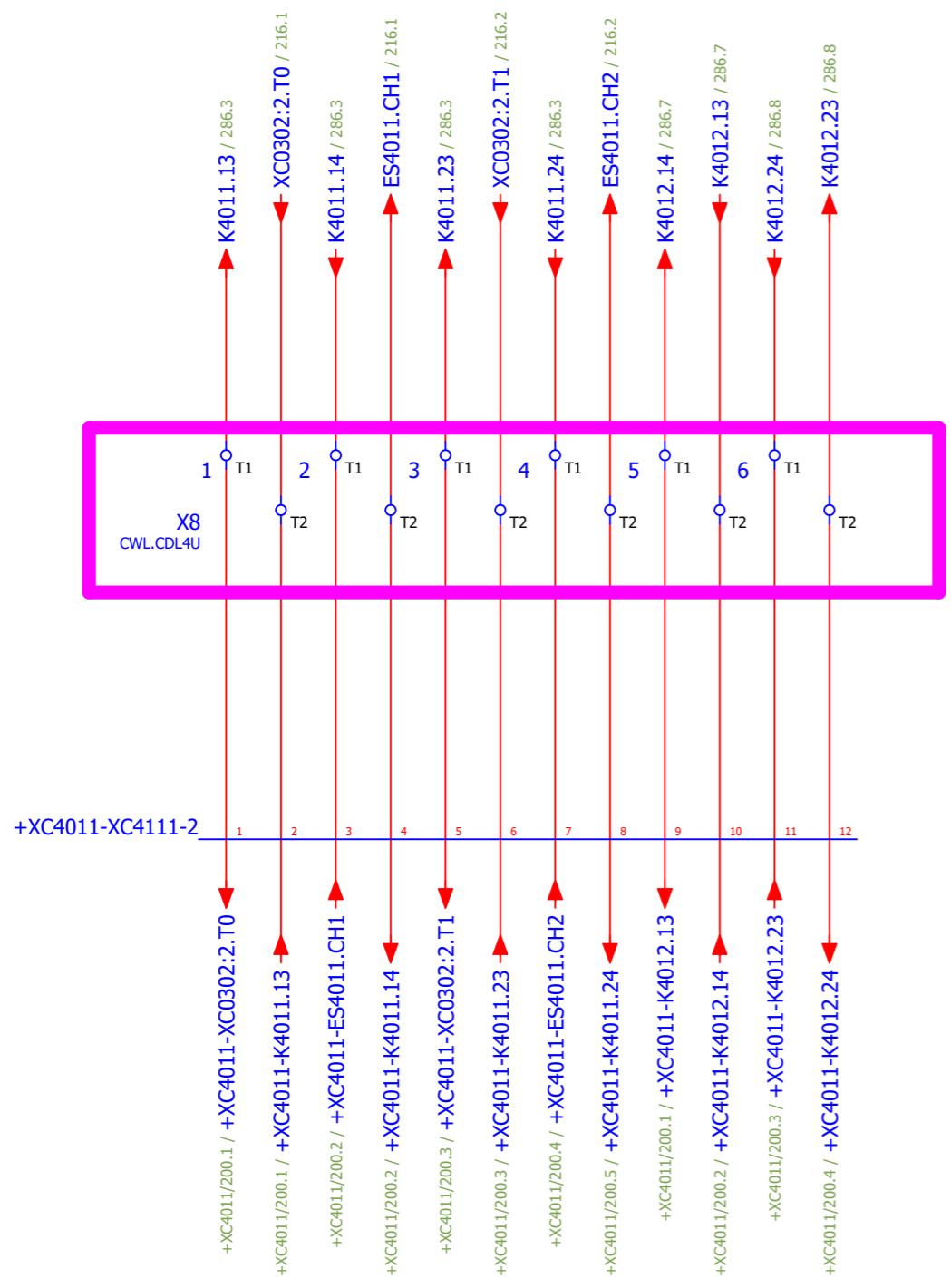

Robot Controller Safety Circuit Connections

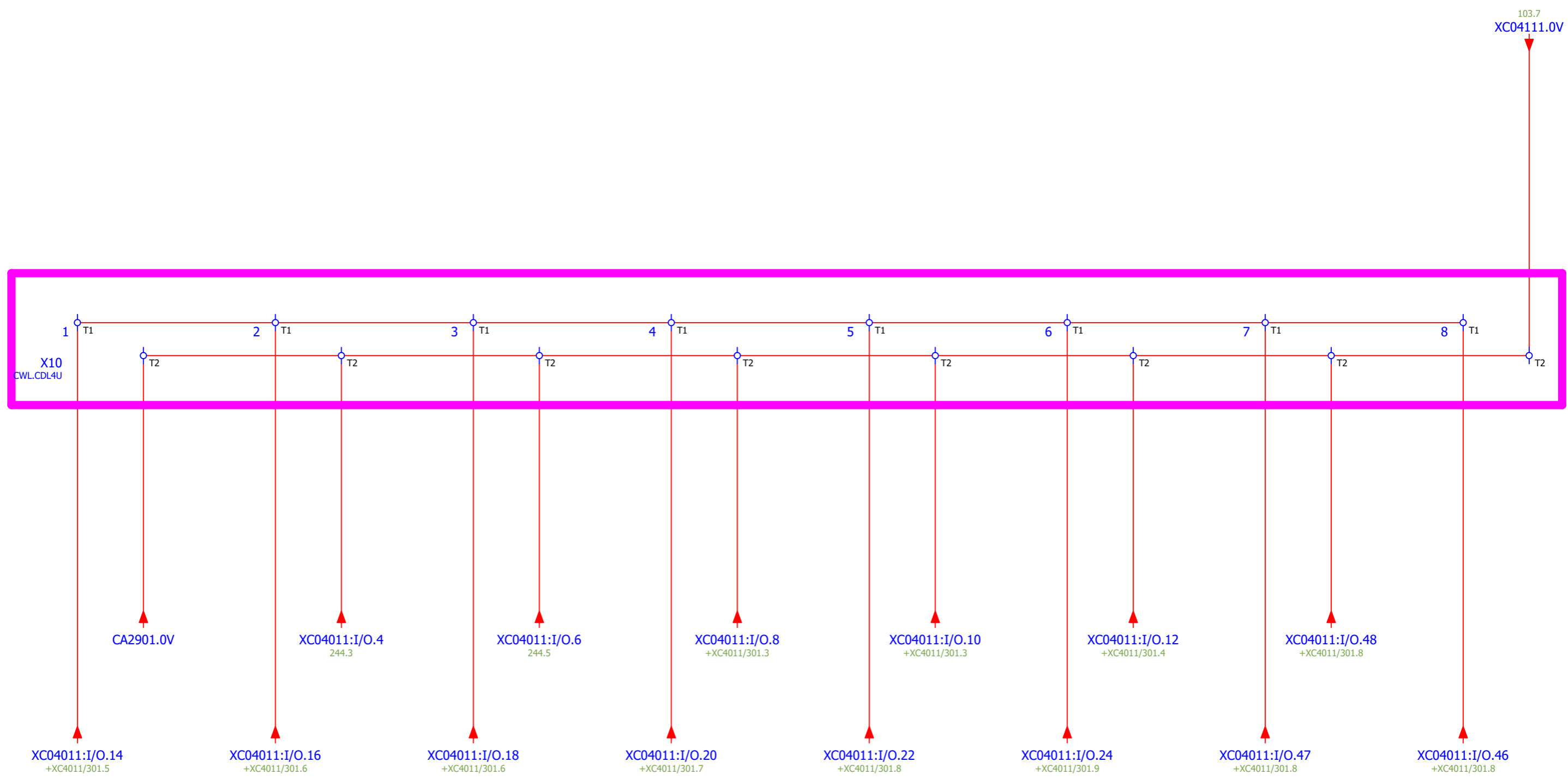

Picking Robot Controller IOs

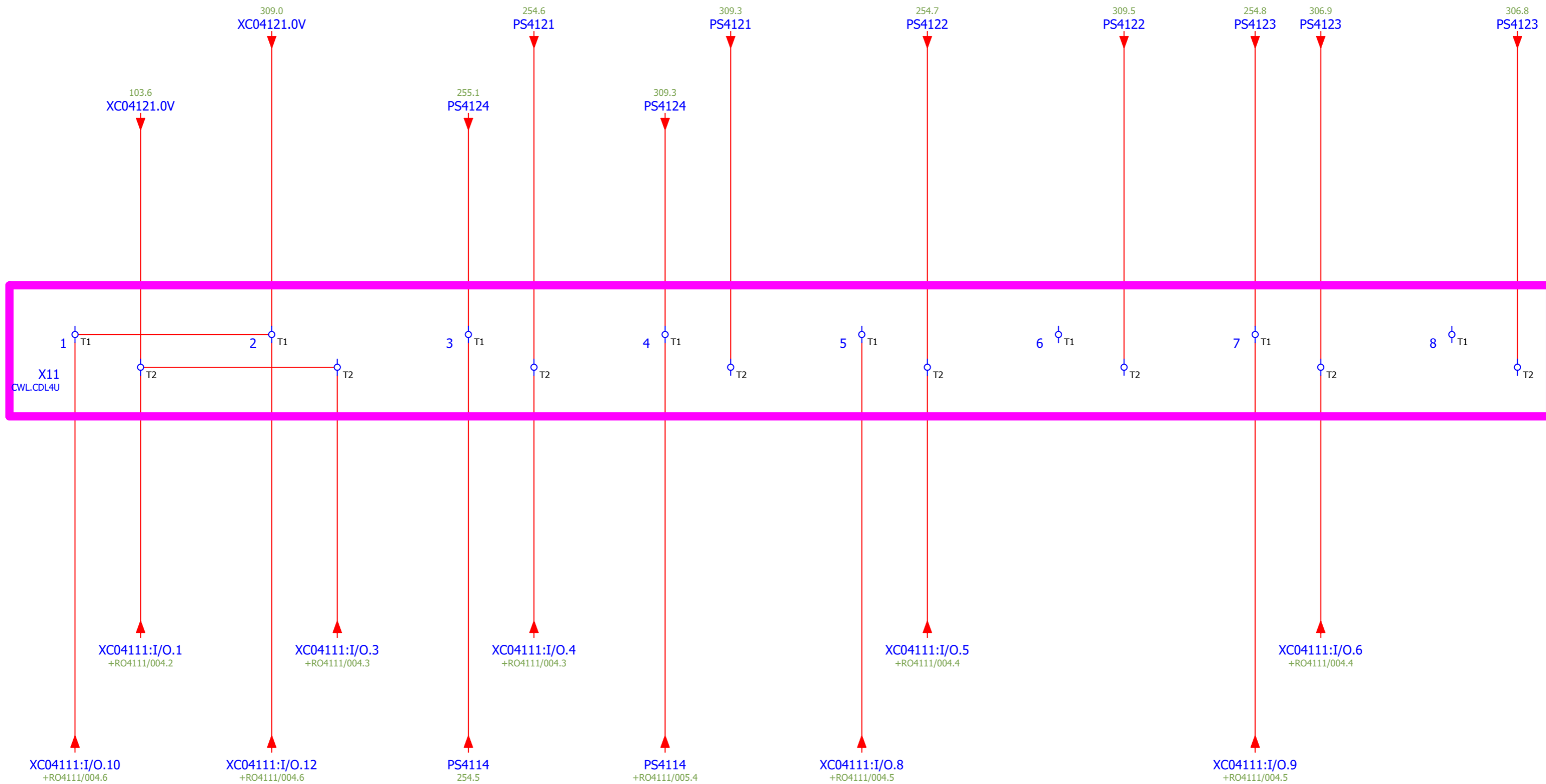

Picking Robot 1 Controller IOs

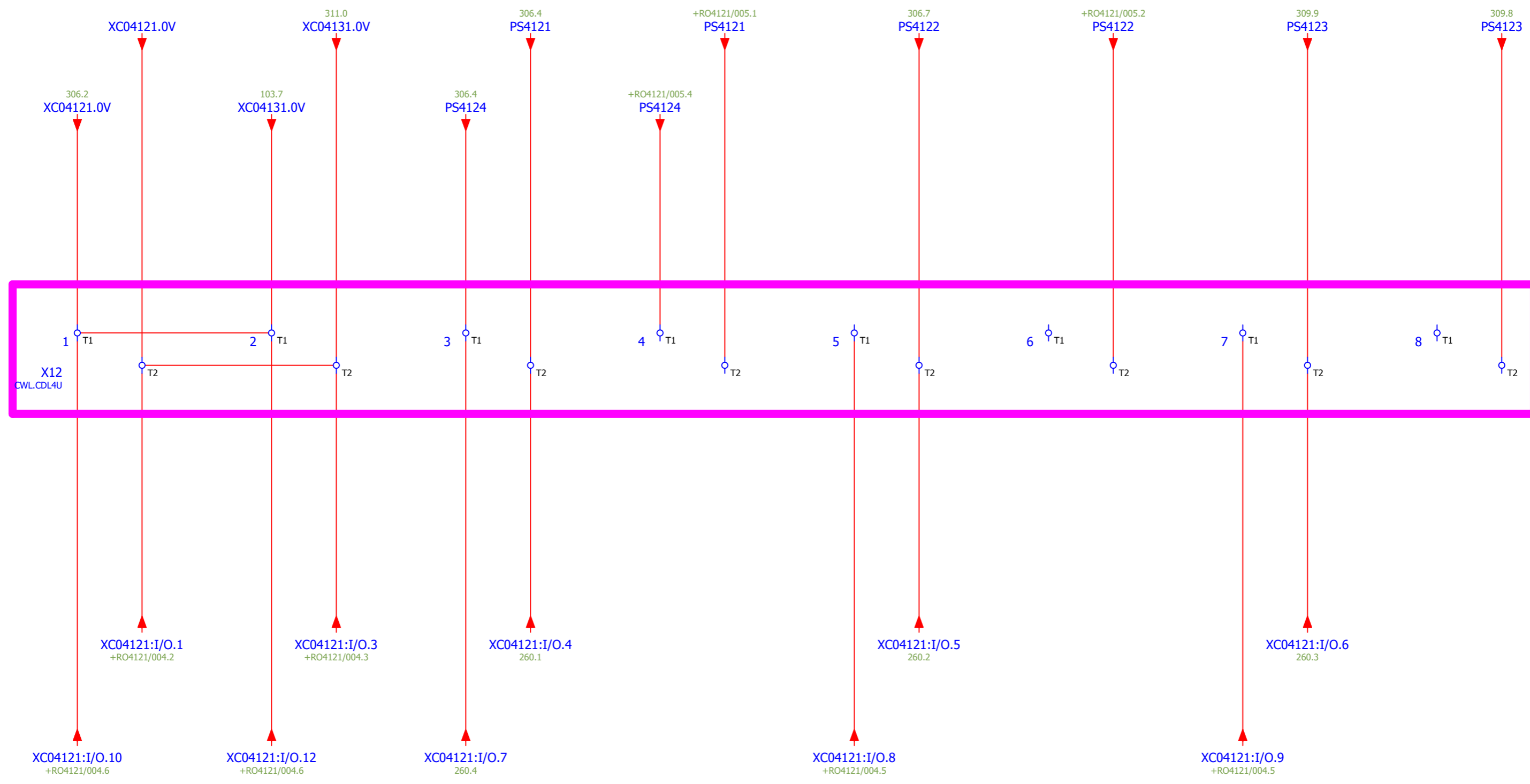

Picking Robot 2 Controller IOs

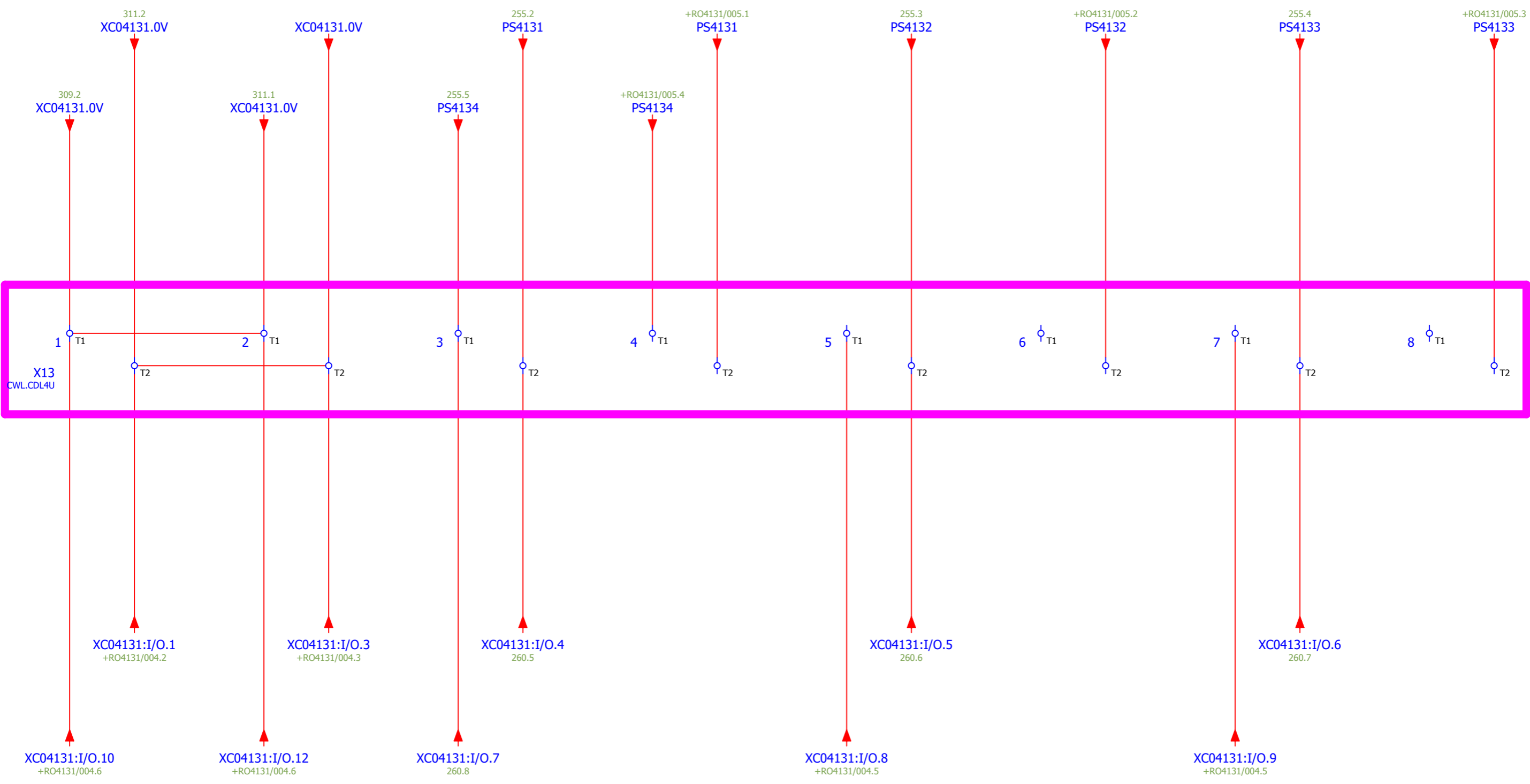

Picking Robot 3 Controller IO

Date Printed: 8/29/2022	Rev:	By:	Date:	Modification:	Page Modified Date: 7/28/2022
Designer: Sahana					

Project Desc: **p780 Sachet Cartoner**

Page Desc: XC4131 Picking Robot 3 Controller Inputs



Mounting Loc: Main Control Cabinet	Job No: 16049-0301	Area: p780	Loc: CP0301
--	-----------------------	---------------	----------------

Page: 311
Next Page: 312

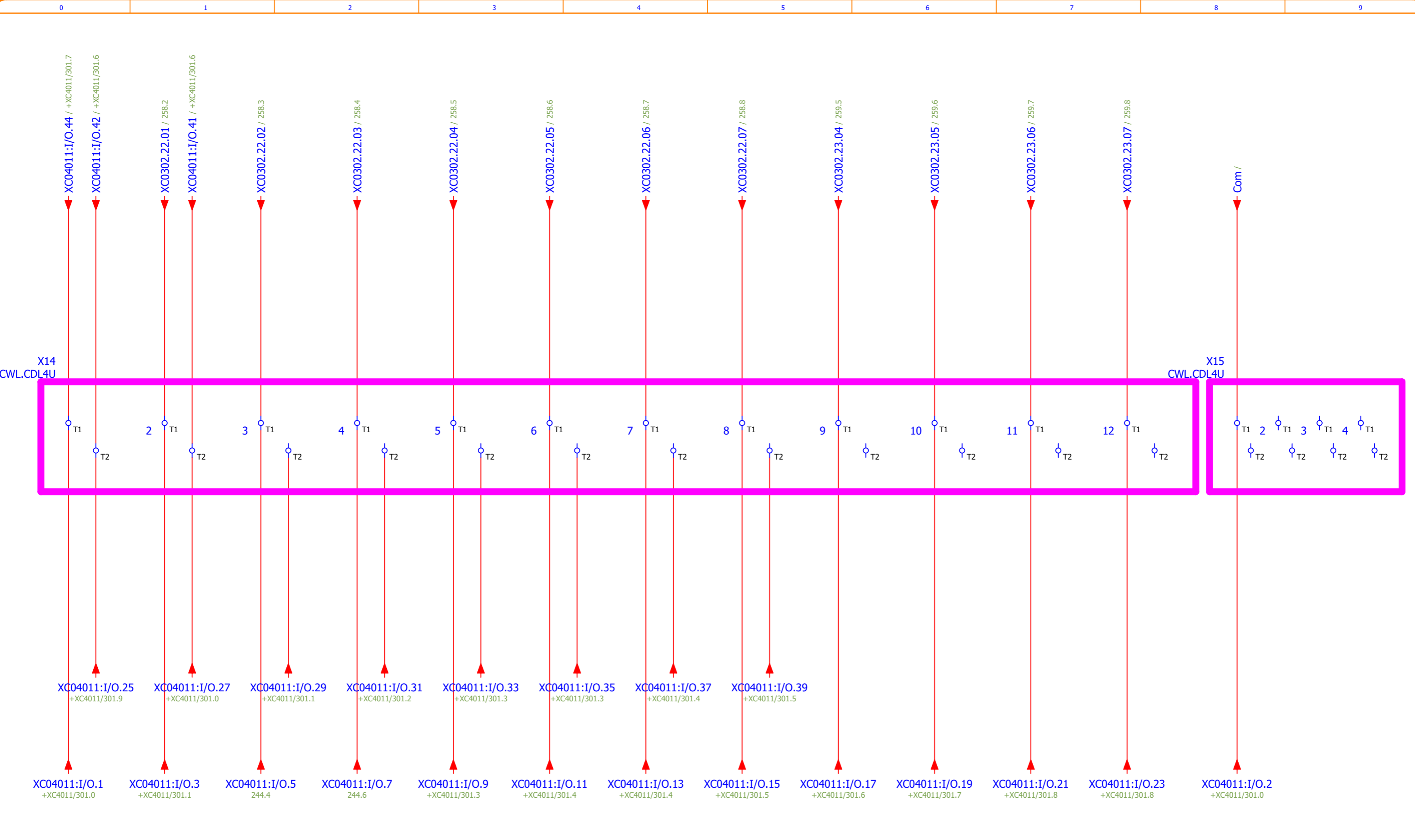

Picking Robot Controller IOs

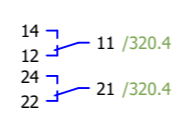
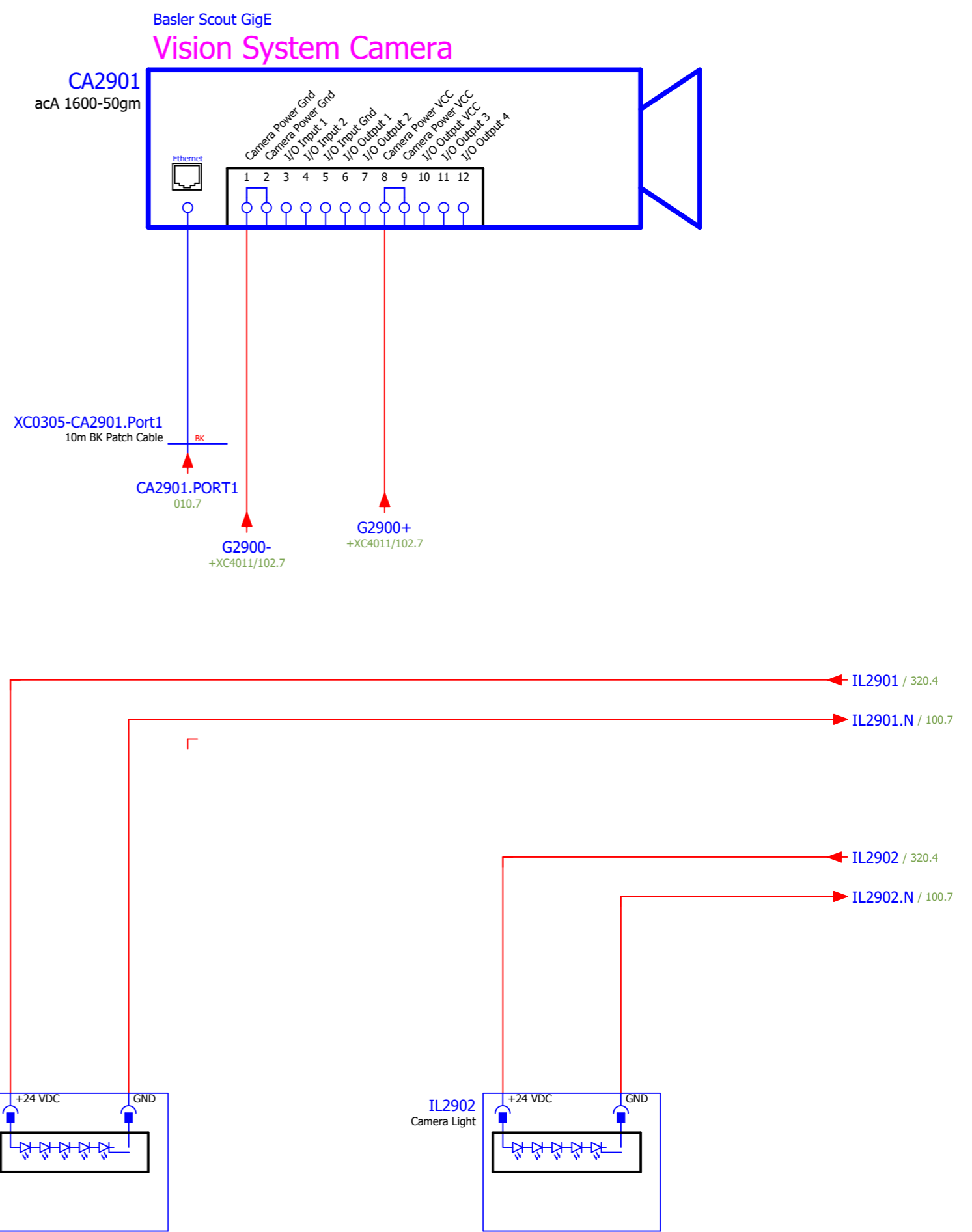
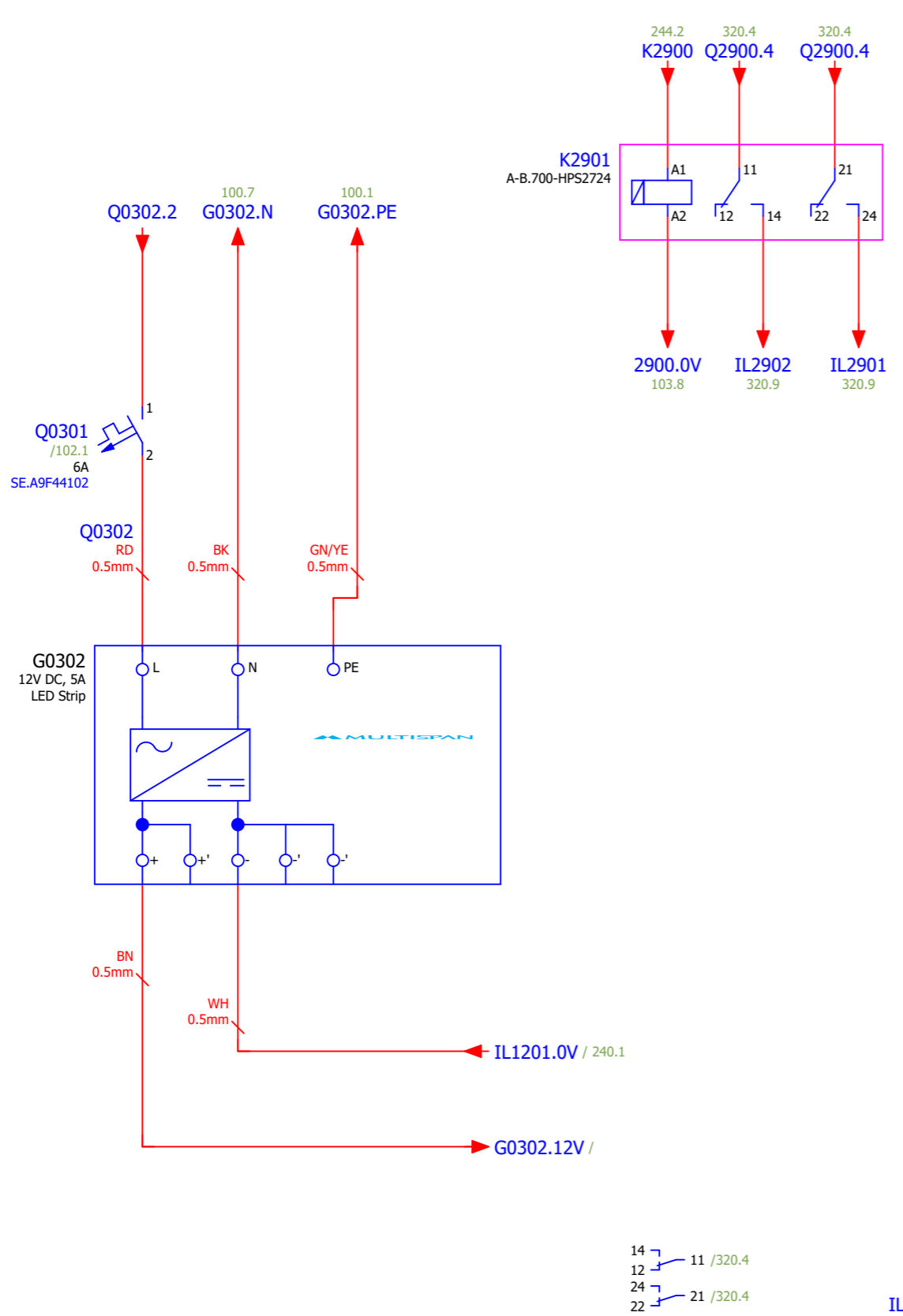

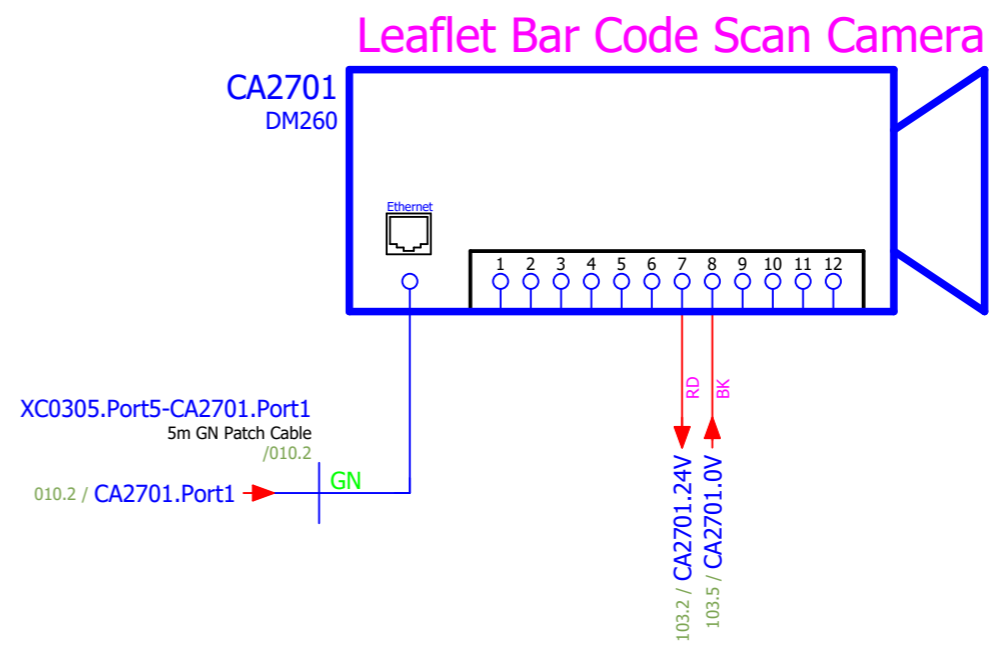
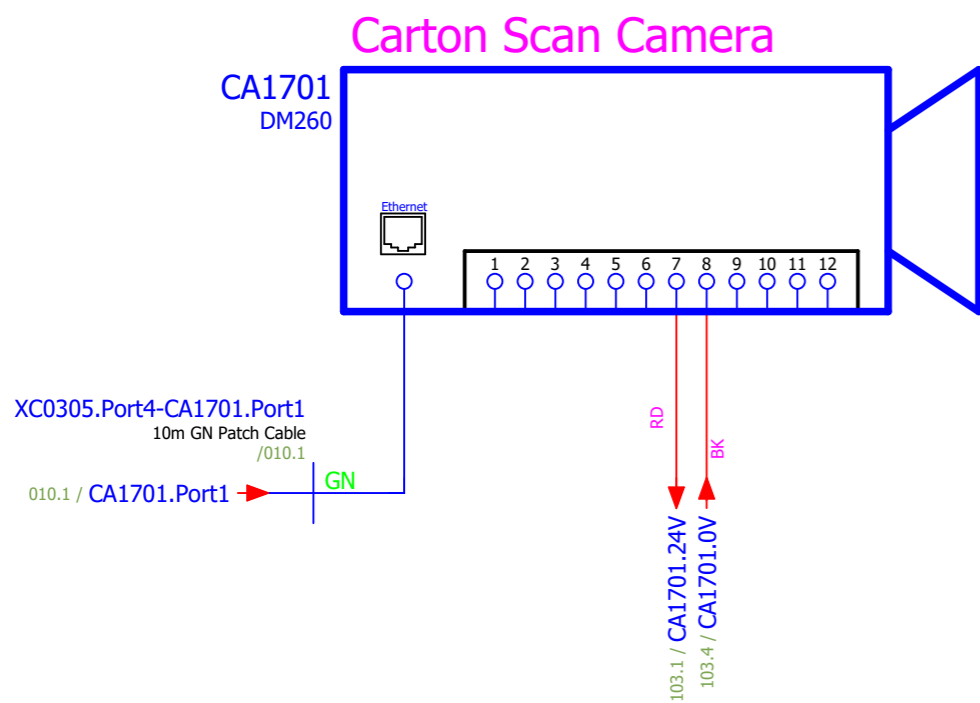

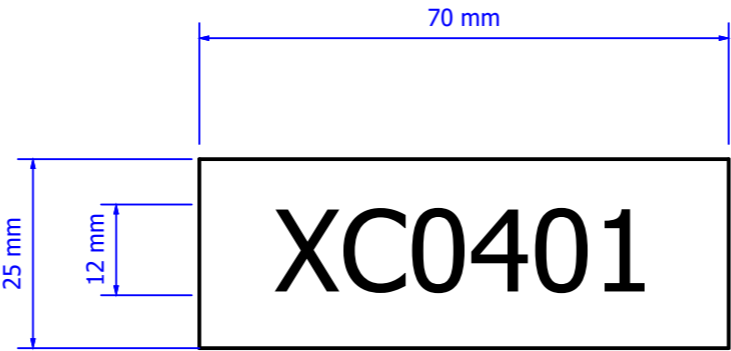

MATERIAL:- 1.6mm WBW TRAFFOLYTE OR PLASTIC
 (BLACK LETTERS ON A WHITE BACKGROUND)
 REVERSE ENGRAVED
 AND SECURED WITH SILCONE.

Date Printed: 8/29/2022	Rev:	By:	Date:	Modification:	Page Modified Date: 10/21/2019
Designer: Sahana					

Project Desc: p780 Sachet Cartoner	
Page Desc: Panel Label	

Mounting Loc: Loader Valve Bank		
Job No: 16049-0301	Area: p780	Loc: XC0401

Page: 002
Next Page: 300

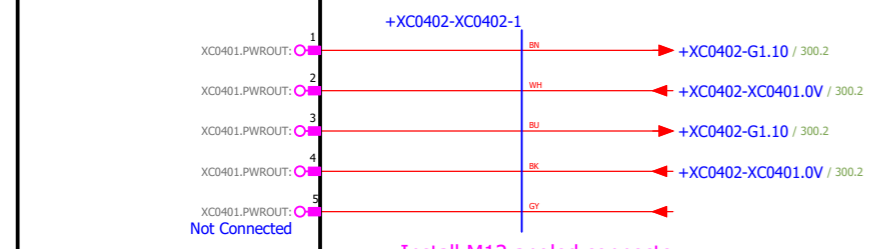
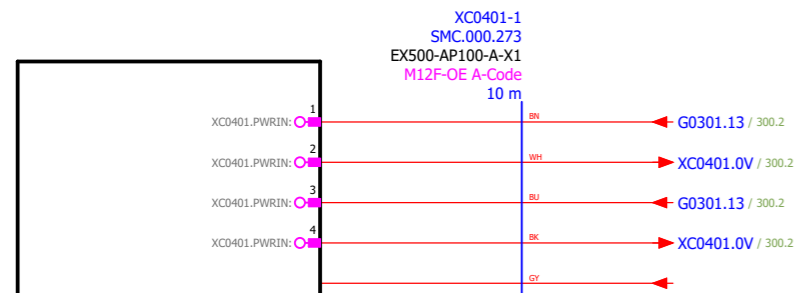
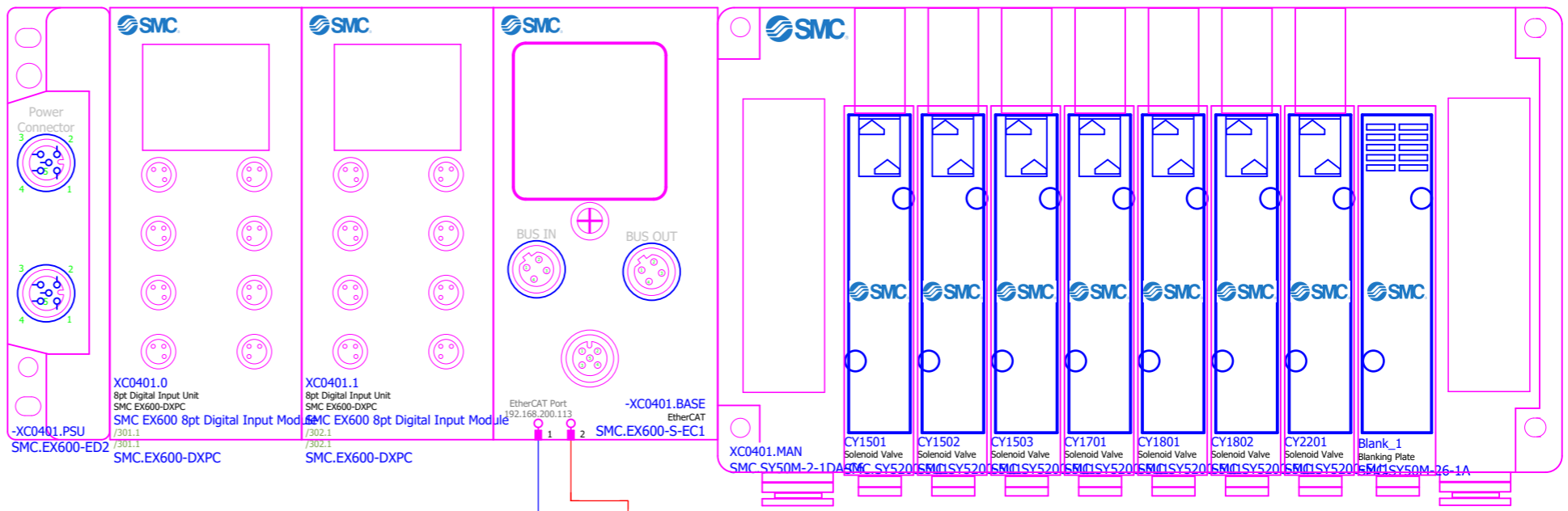

Install M12 angled connector on to free cable end

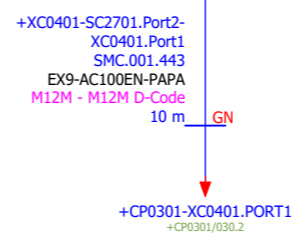
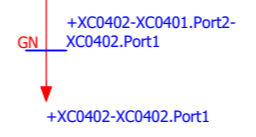

Power Cable Connections		
Pin #	Wire Colour	Signal
1	BN	24 V (Output)
2	WH	0 V (Output)
3	BU	24 V (Control and input)
4	BK	0 V (Control and input)
5	GY	Not Connected

BUS IN Cable Connections		
Pin #	Wire Colour	Signal
1	White/Orange	TX+ Transmitted Data+
2	White/Green	RX+ Retrieved Data+
3	Orange	TX- Transmitted Data-
4	Green	RX- Recieved Data-
Housing	Screen	

XC0401.0
/300.3
SMC EX600-DXPC
8pt Digital Input Unit

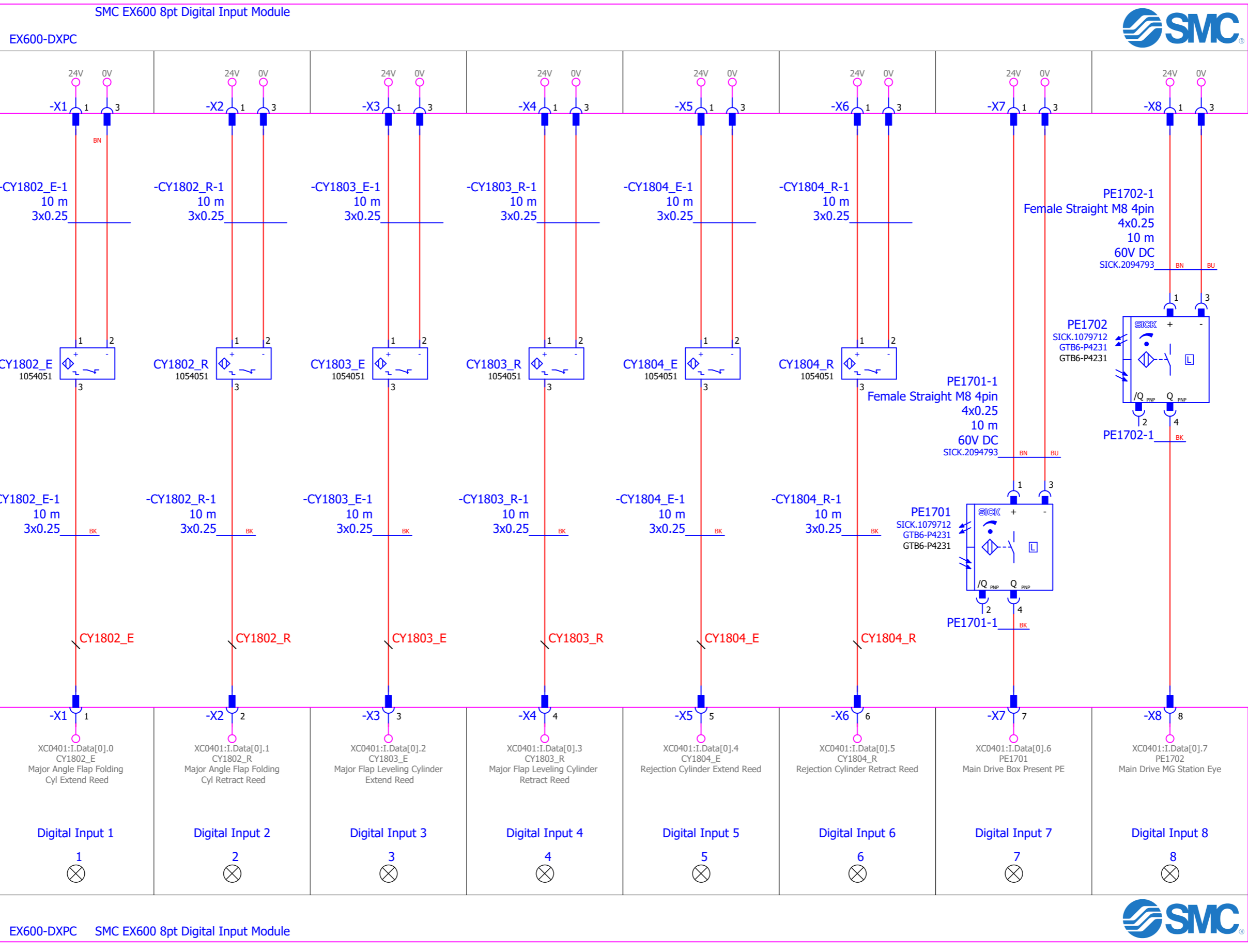

XC0401.0
/300.3
SMC EX600-DXPC
8pt Digital Input Unit

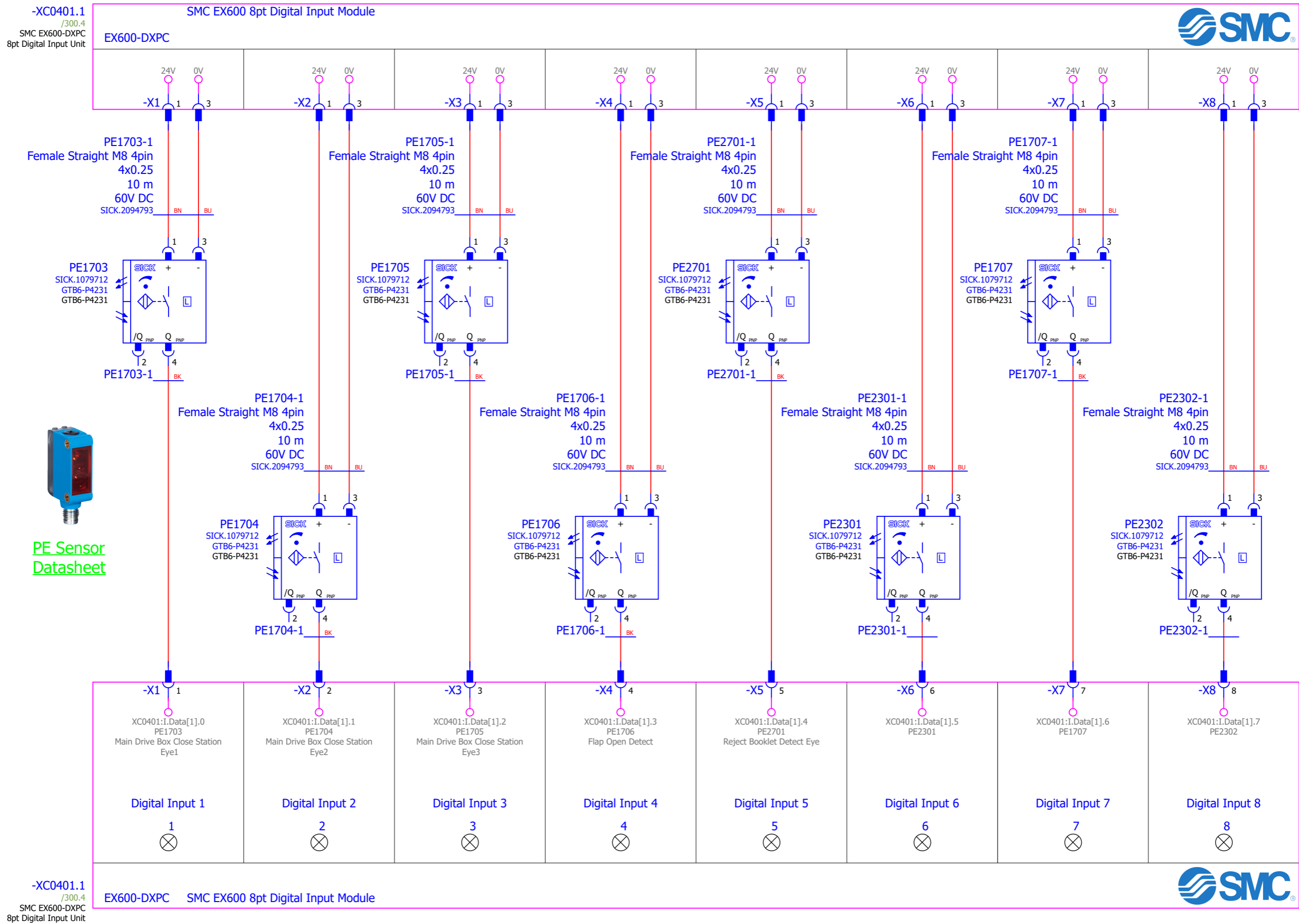

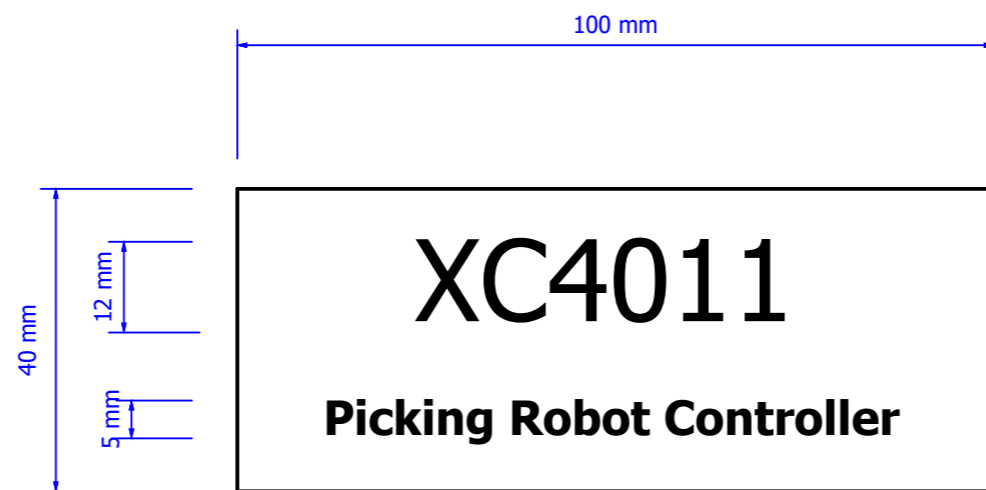

MATERIAL:- 1.6mm WBW TRAFFOLYTE OR PLASTIC
 (BLACK LETTERS ON A WHITE BACKGROUND)
 REVERSE ENGRAVED
 AND SECURED WITH SILCONE.

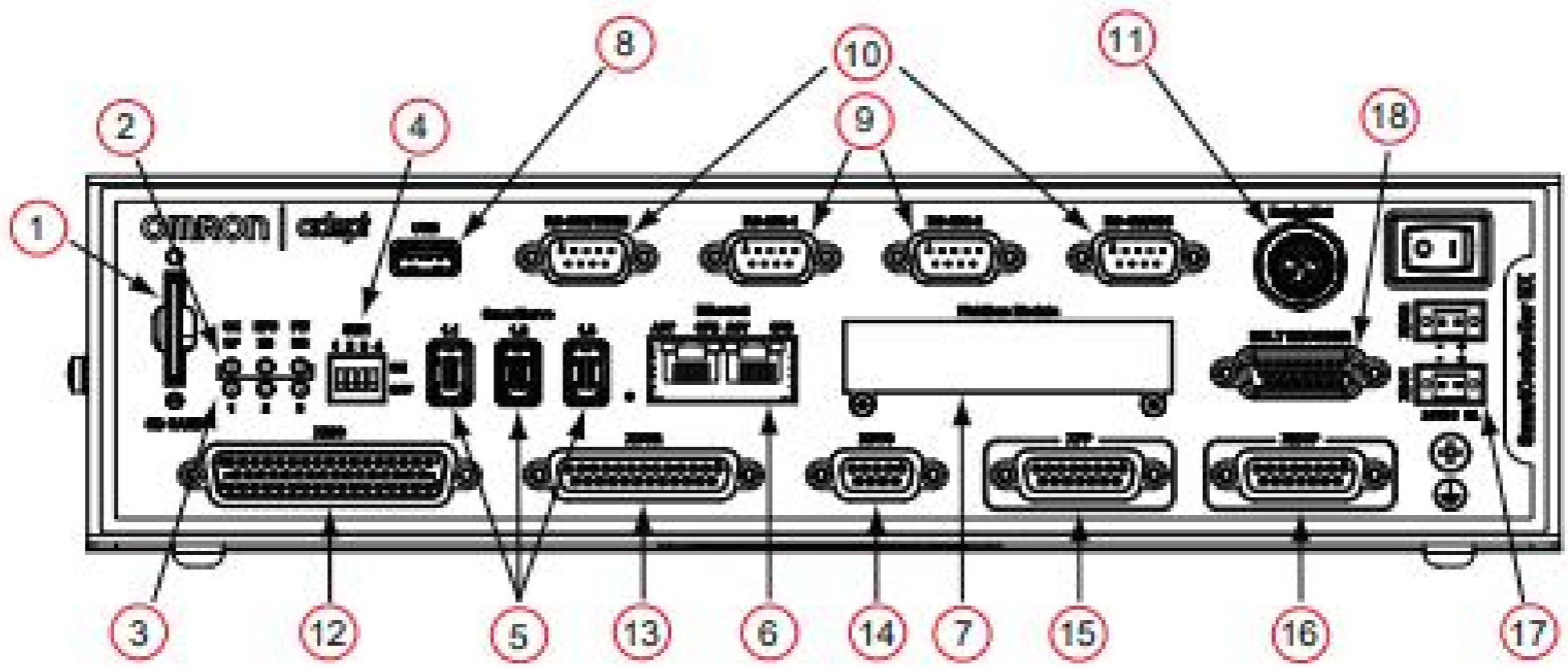

1 . SD Card Slot

2 . Top Three Status LEDs

LED	Green Indicates	Red Indicates
OK/SF	System OK	System Fault
HPE/ES	High Power Enabled	E-Stop Open
FW/HD	SmartServo Connection	Read / Write from SD card

3. Bottom Three Status LEDs

O= Off G=Green R=Red

LED Display 1 2 3	Error Number	Description
O-O-O	0	No error.
R-O-O	1	System clock is dead or too fast. Clock interrupts are not being received.
O-R-O	2	Hardware configuration error.
O-O-R	4	Memory test failure. Free storage error.
O-R-R	6	Software serial I/O configuration error.
R-R-R	7	Initial display set by hardware before software has started.
G-O-O	9	Transient display set when PCI is configured.
O-O-G	C	Uninitialized trap.
G-O-G	D	Bus error detected.

4. SW1 DIP switches

5. SmartServo 1.1, 1.2, and 1.3

6. Ethernet (Eth 10/100/1000) connectors

7. Fieldbus Module

8. USB port

9. RS-232-1 and RS-232-2 connectors

10. RS-232 and RS-422 / 485 connectors

11. DeviceNet connector

12. XIO connector

13. XUSR connector

14. XSYS connector

15. XFP connector

16. XMCP connector

17. 24 VDC connectors / switch

18. Belt Encoder connector



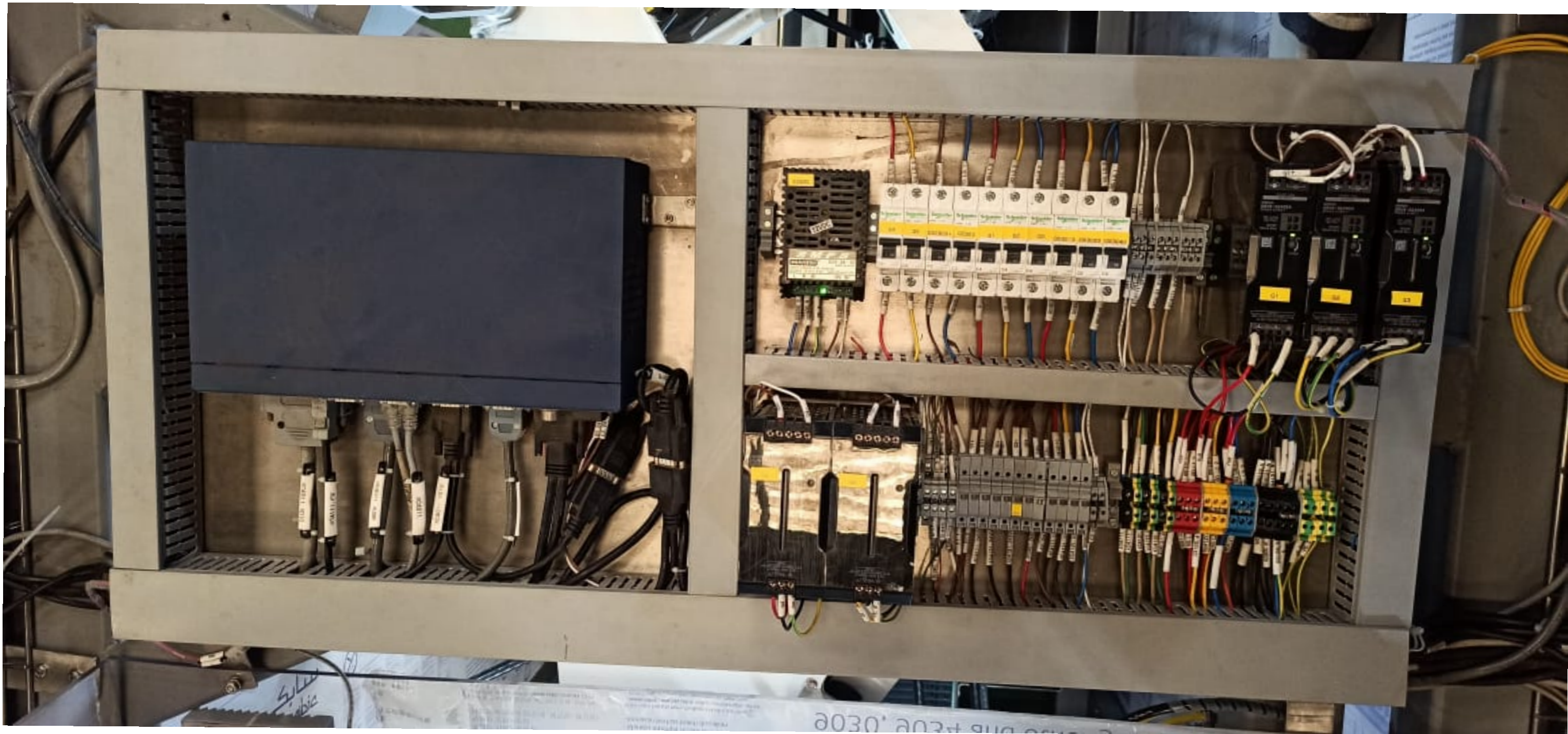

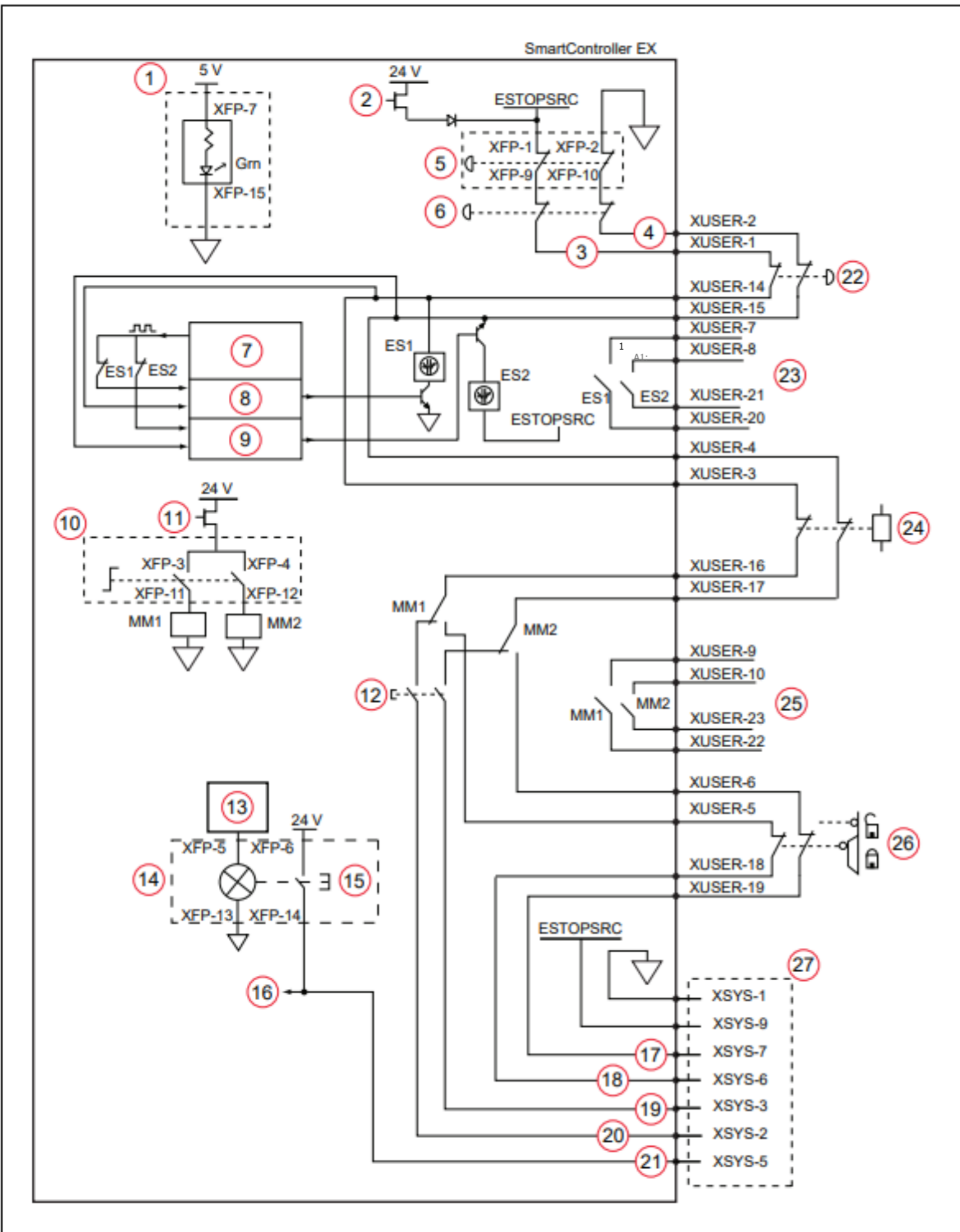

Item	Description
1	Front panel system power LED
2	E-Stop enable (current limit 1.4 A max.)
3	Channel 1 (E-Stop)
4	Channel 2 (E-Stop)
5	Front panel E-Stop
6	Pendant E-Stop
7	Logic cyclic check state machines
8	Channel 1 (logic cyclic check state machines)
9	Channel 2 (logic cyclic check state machines)
10	Front panel - Manual / Auto keyswitch
11	Manual / Auto enable
12	Pendant enable switch
13	Lamp control circuit with burnout detection
14	Front panel
15	High power ON / OFF
16	eV+ High power request
17	Auto 2
18	Auto 1
19	Manual 2
20	Manual 1
21	High power request
22	User E-Stop and gate interlock (jumper closed when not in use, must open both channels independently if used)
23	User E-Stop indication
24	Line E-Stop (external user E-Stop system)
25	User manual / auto indication (manual = open)
26	Muted safety gate - active in auto mode only (jumper closed when not used)
27	Connections at robot or module system (no user connections)

NOTE :XUSER-2 & 15 ,XUSER-5 & 18,XUSER-6 & 19 ARE SHORTED AS PER MENTIONED CIRCUIT

Patch Cable Pin Out

Wire	Pin #
White/Orange	1
Orange	2
White/Green	3
Blue	4
White/Blue	5
Green	6
White/Brown	7
Brown	8



A31.1
Robot Controller

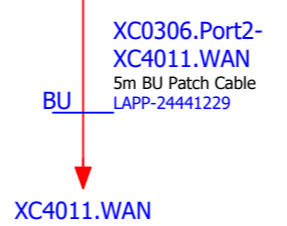
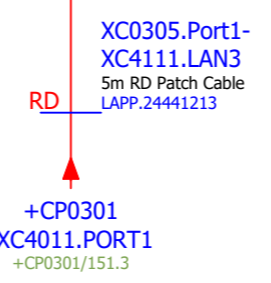
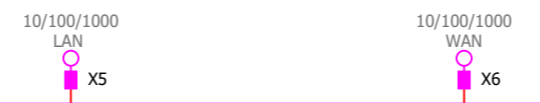
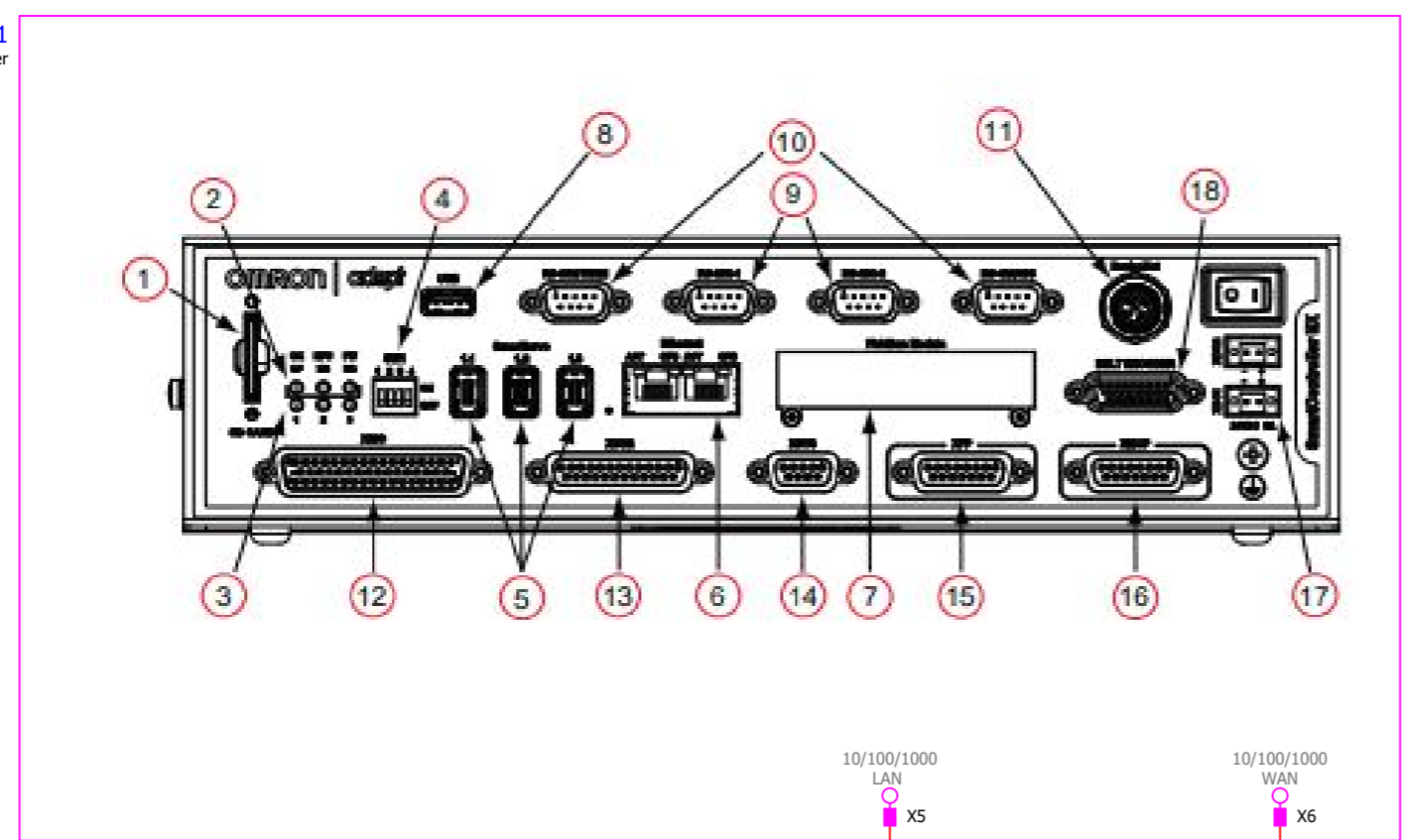

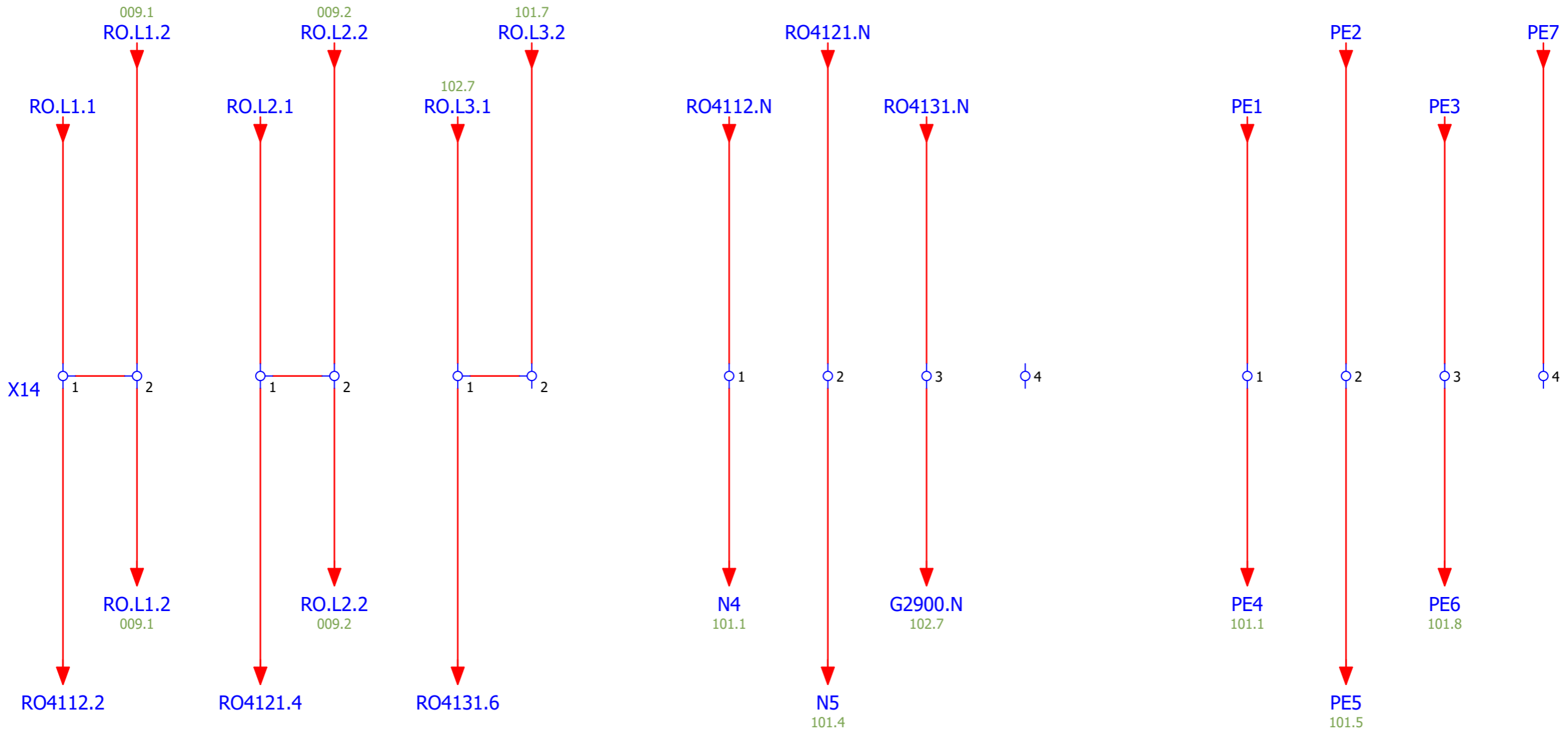

Power Connections

Neutral Connections

Ground Connections



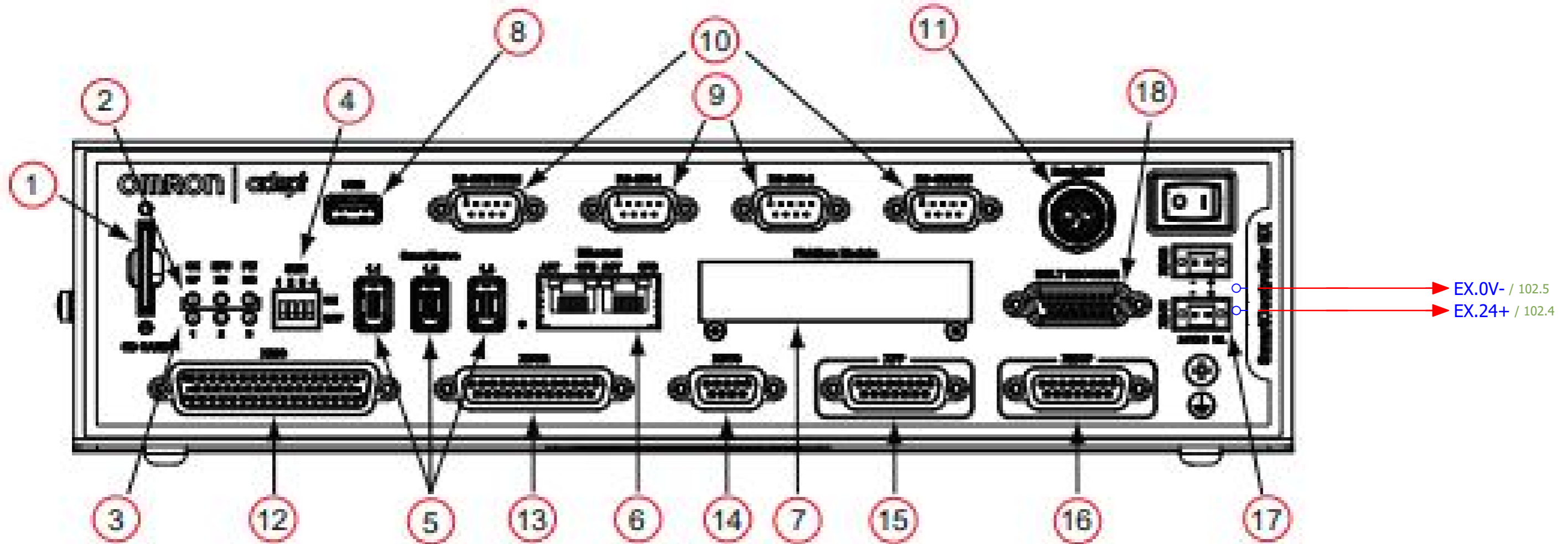

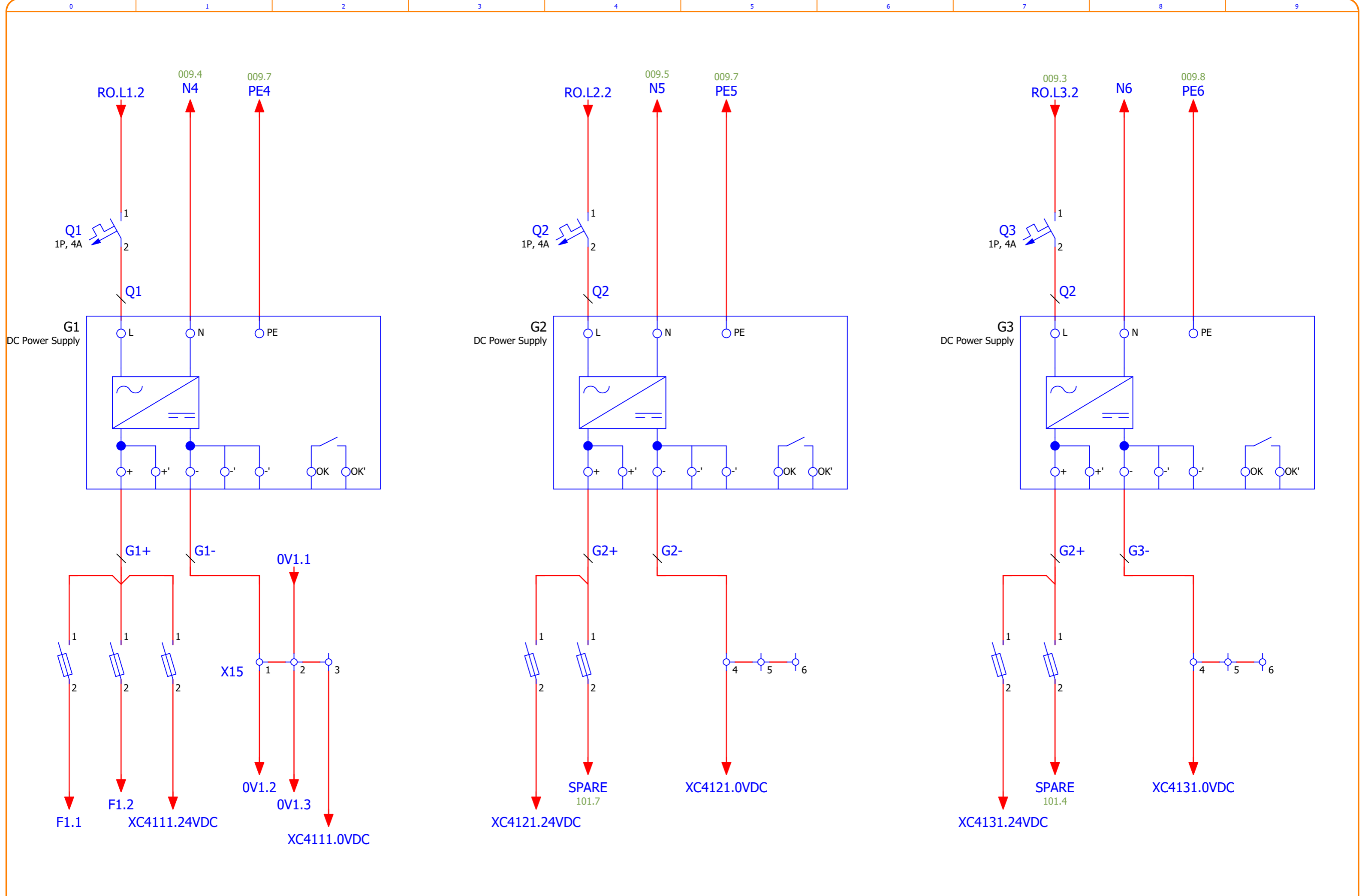

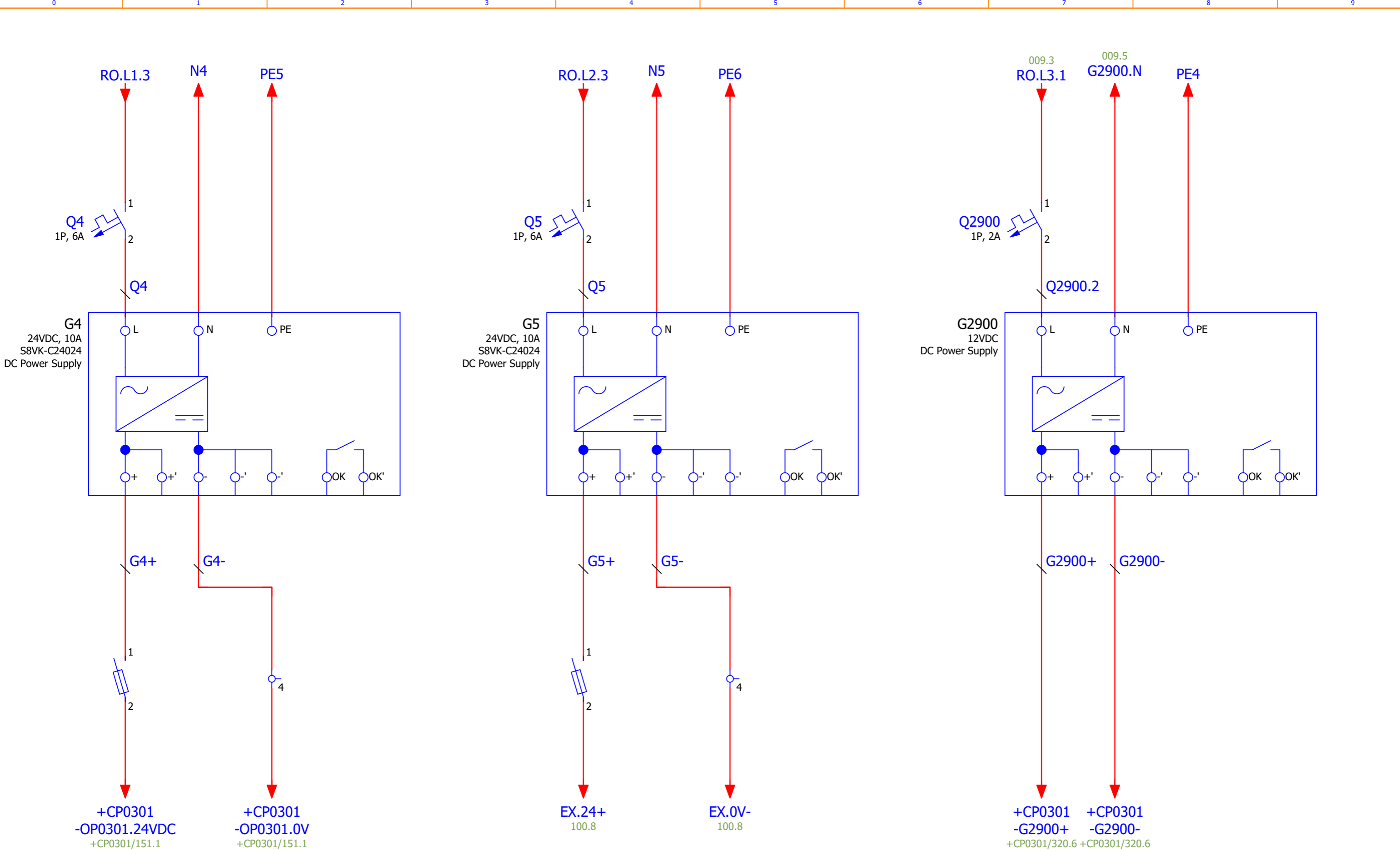

REFER THE XUSER CIRCUIT FROM 007 Page

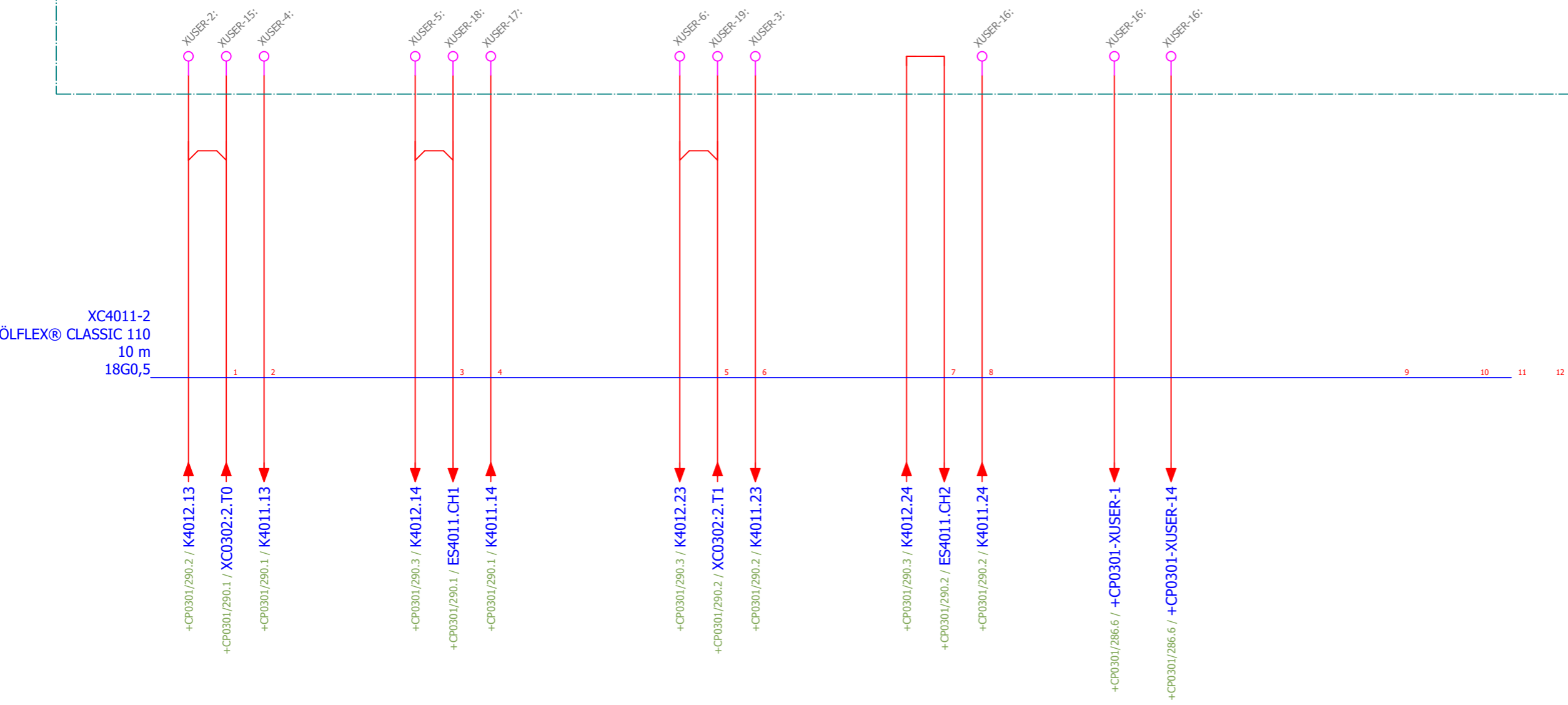

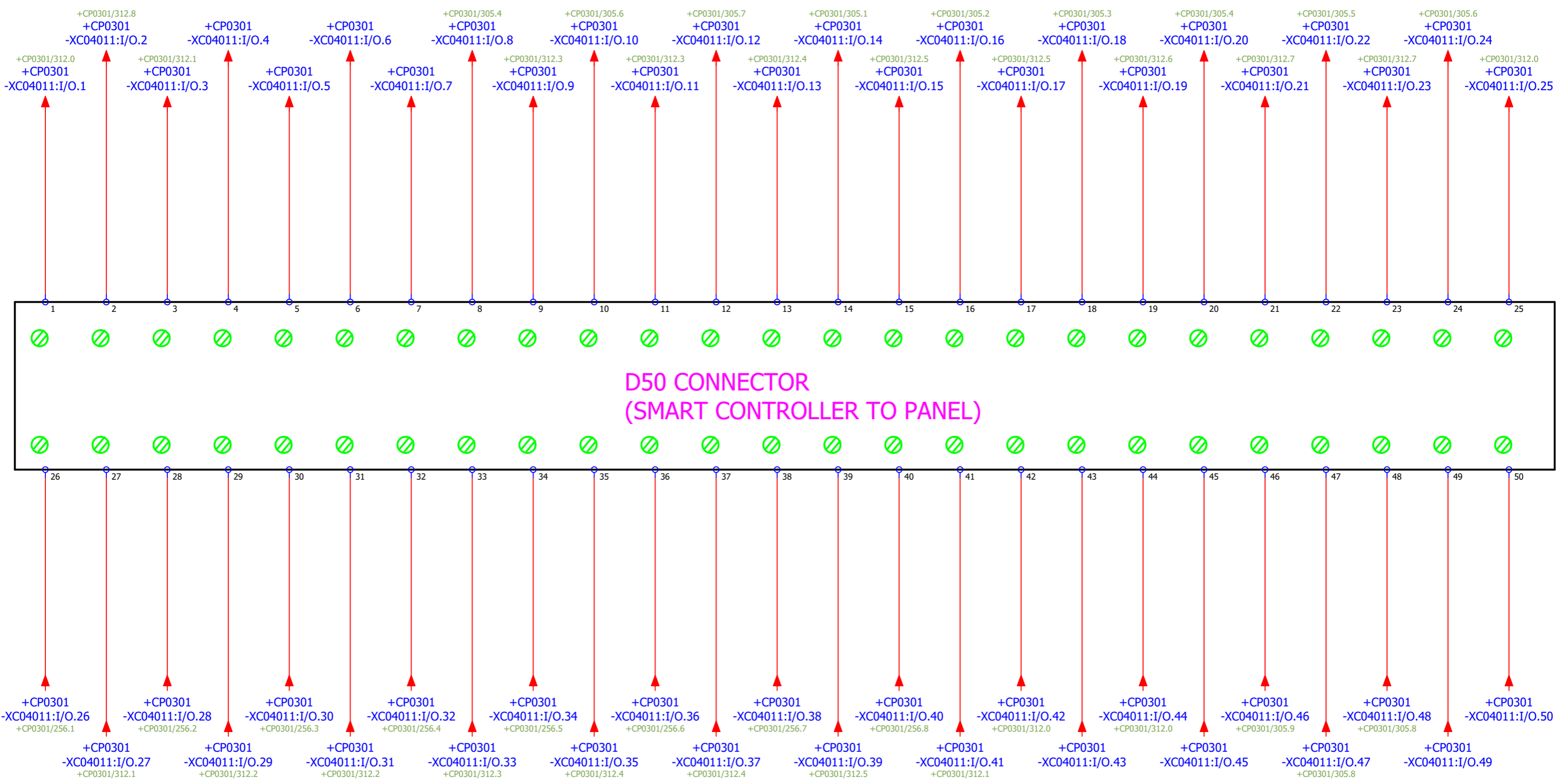

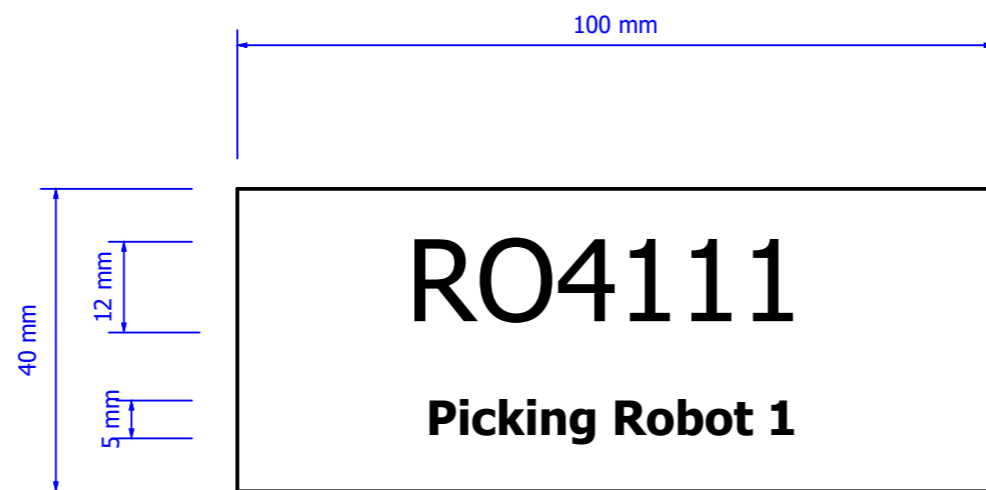

MATERIAL:- 1.6mm WBW TRAFFOLYTE OR PLASTIC
 (BLACK LETTERS ON A WHITE BACKGROUND)
 REVERSE ENGRAVED
 AND SECURED WITH SILCONE.

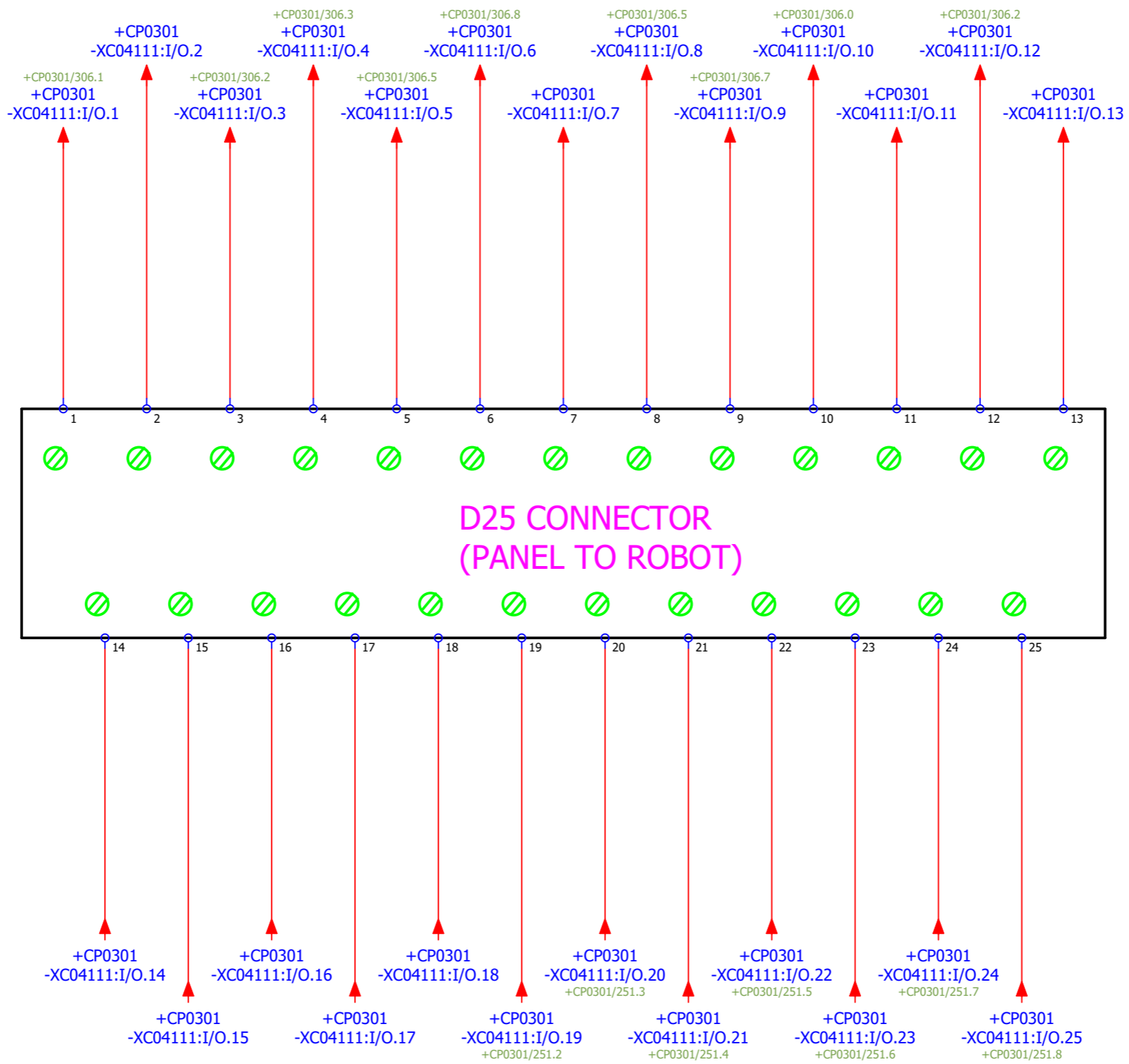

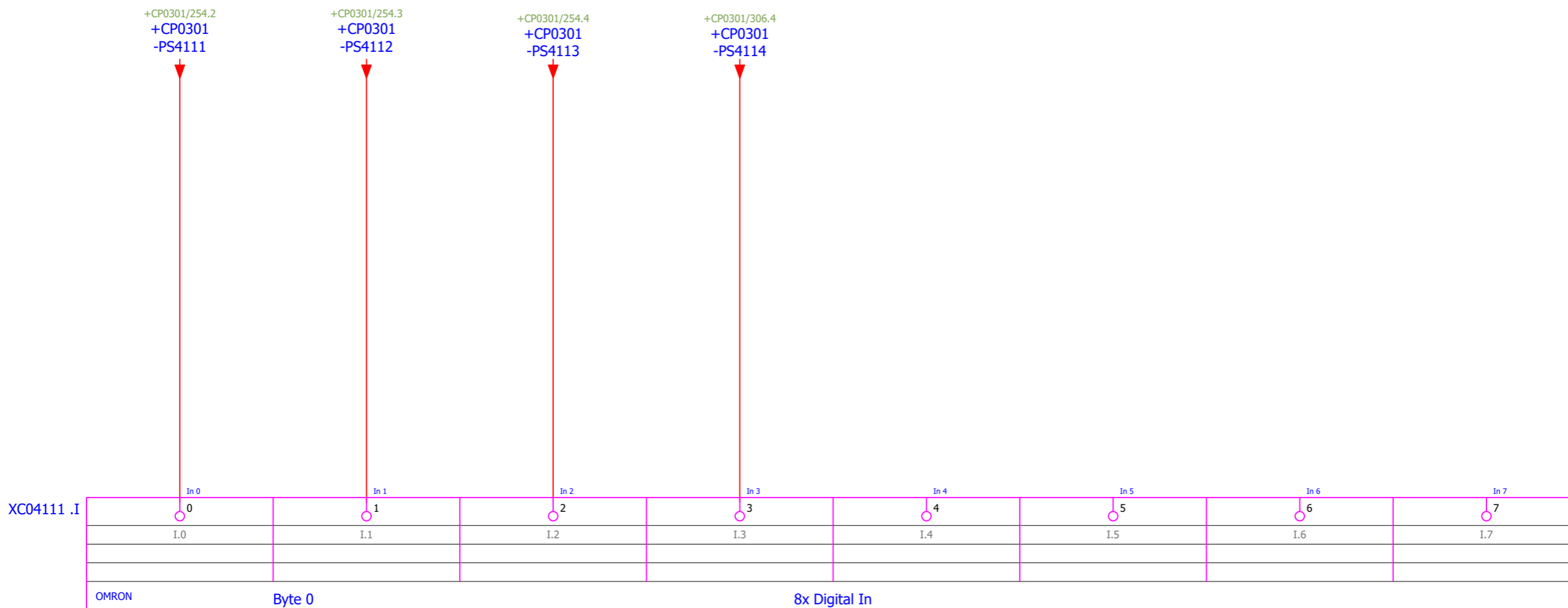

XC4111.0

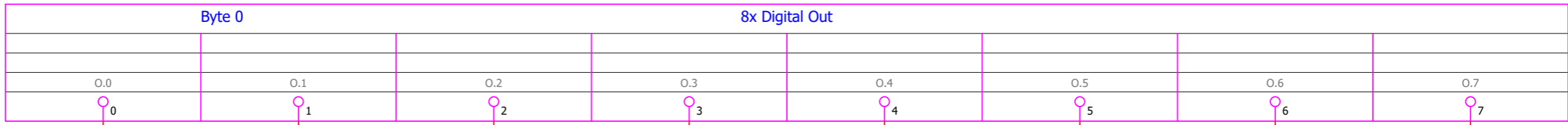

+CP0301-SV4111
+CP0301/241.1

+CP0301-SV4112
+CP0301/241.2

+CP0301-SV4113
+CP0301/241.3

+CP0301-SV4114
+CP0301/241.4

+CP0301-SV4115
+CP0301/241.5

+CP0301-SV4116
+CP0301/241.6

+CP0301-SV4117
+CP0301/241.7

+CP0301-SV4118
+CP0301/241.8



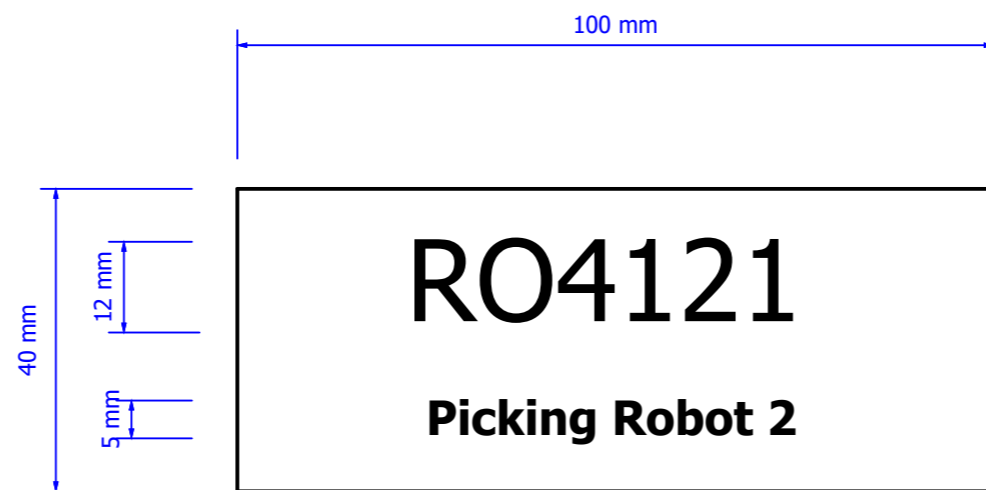

MATERIAL:- 1.6mm WBW TRAFFOLYTE OR PLASTIC
 (BLACK LETTERS ON A WHITE BACKGROUND)
 REVERSE ENGRAVED
 AND SECURED WITH SILCONE.

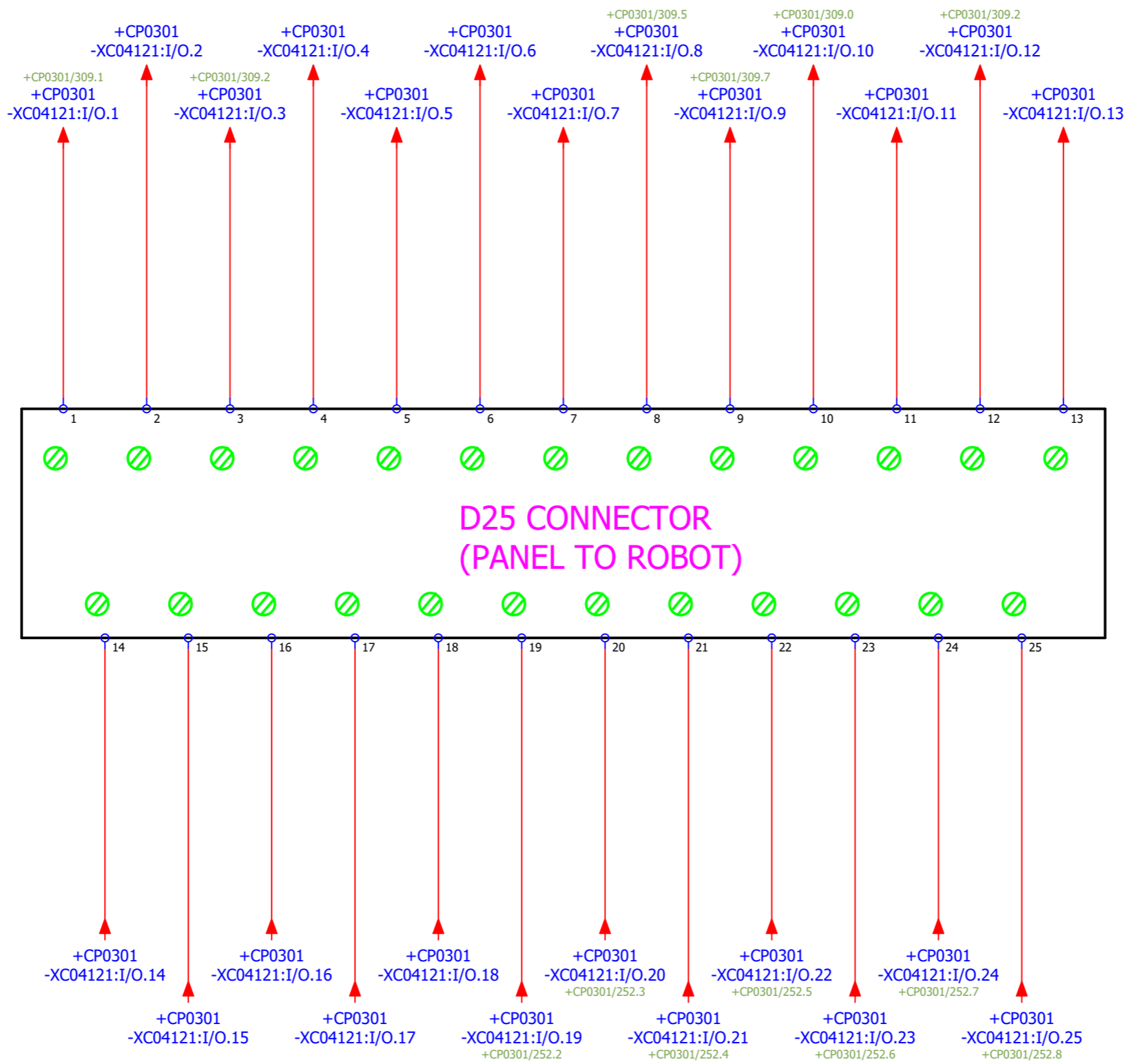

0 1 2 3 4 5 6 7 8 9

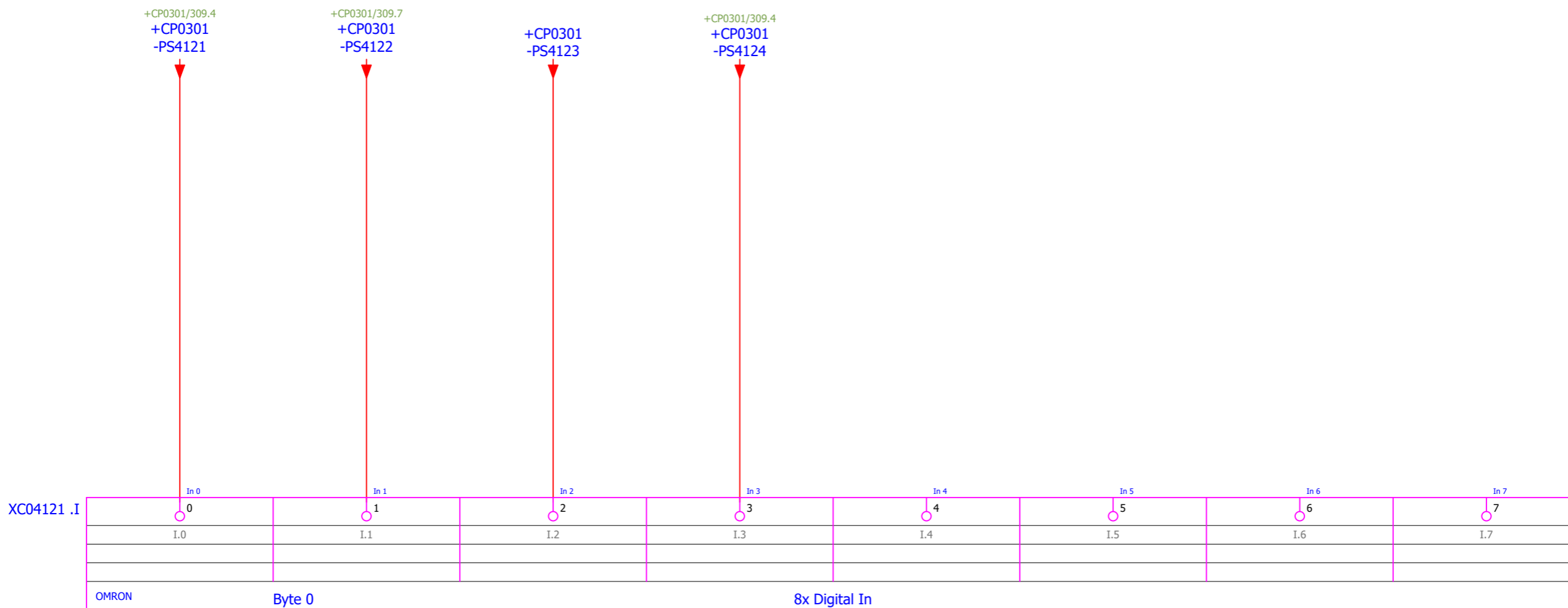

XC4121.0

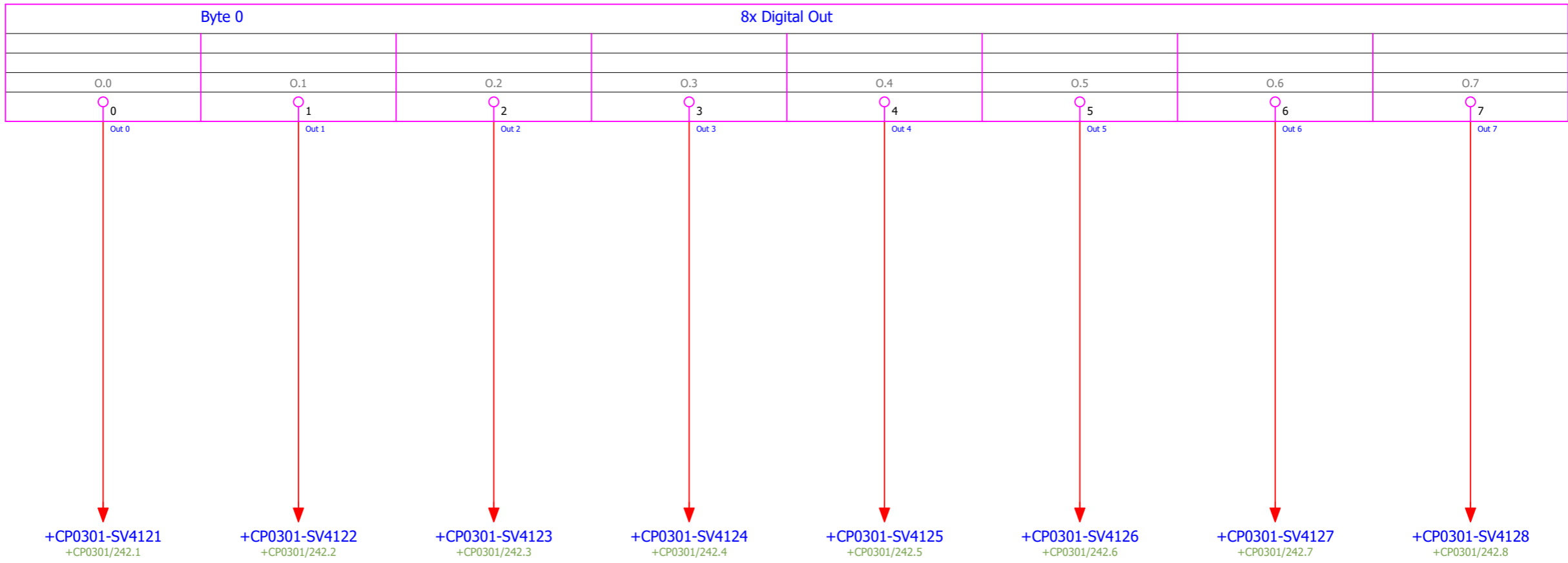

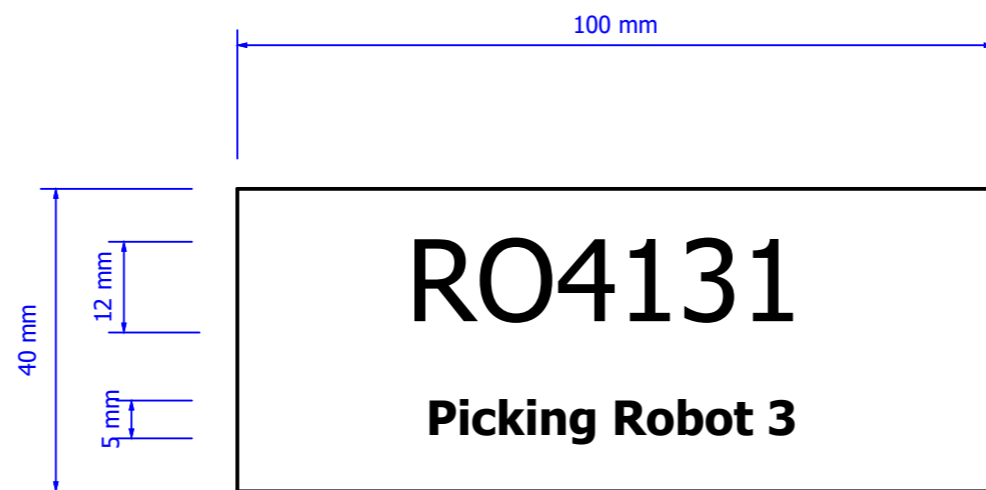

MATERIAL:- 1.6mm WBW TRAFFOLYTE OR PLASTIC
 (BLACK LETTERS ON A WHITE BACKGROUND)
 REVERSE ENGRAVED
 AND SECURED WITH SILCONE.

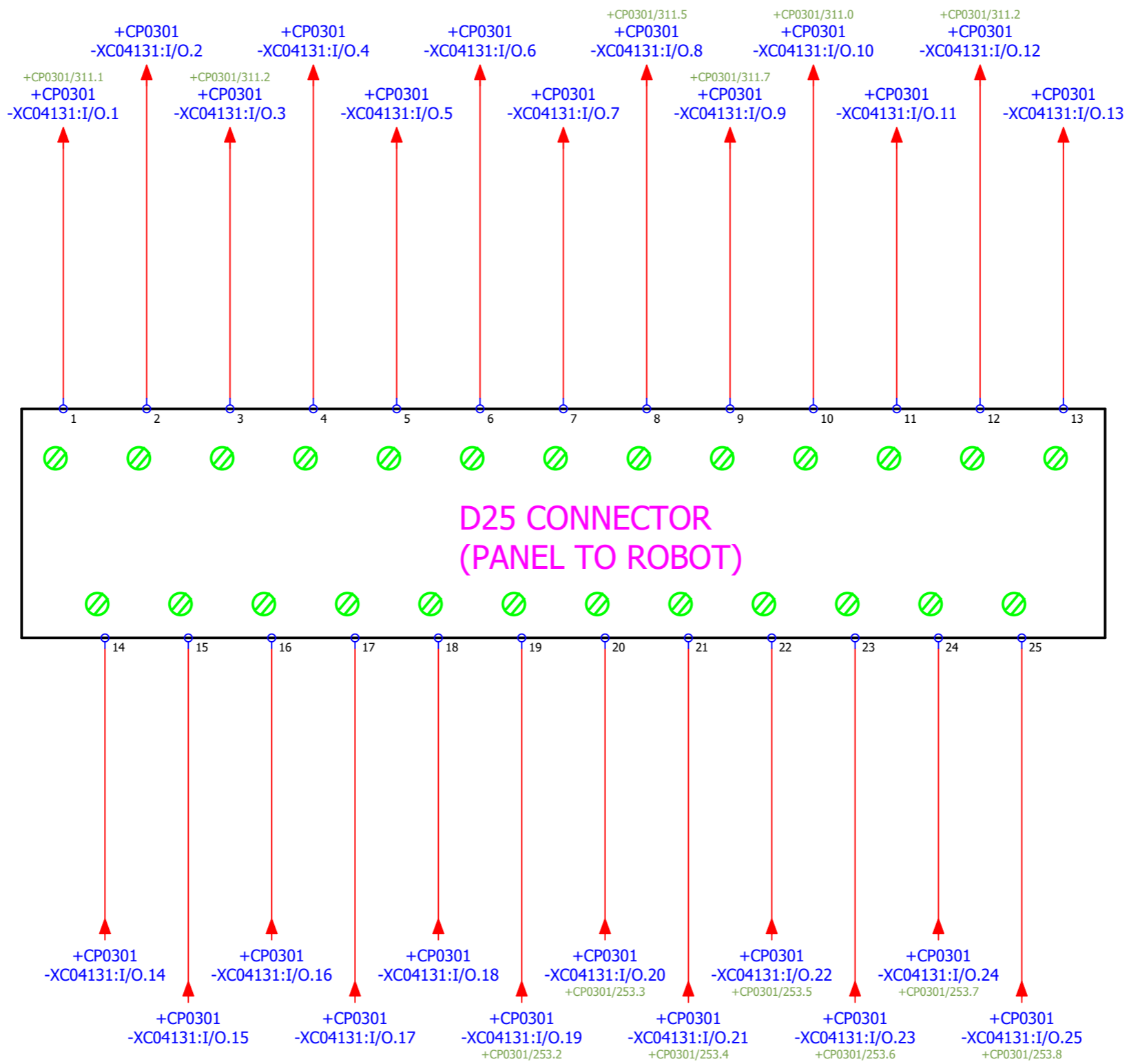

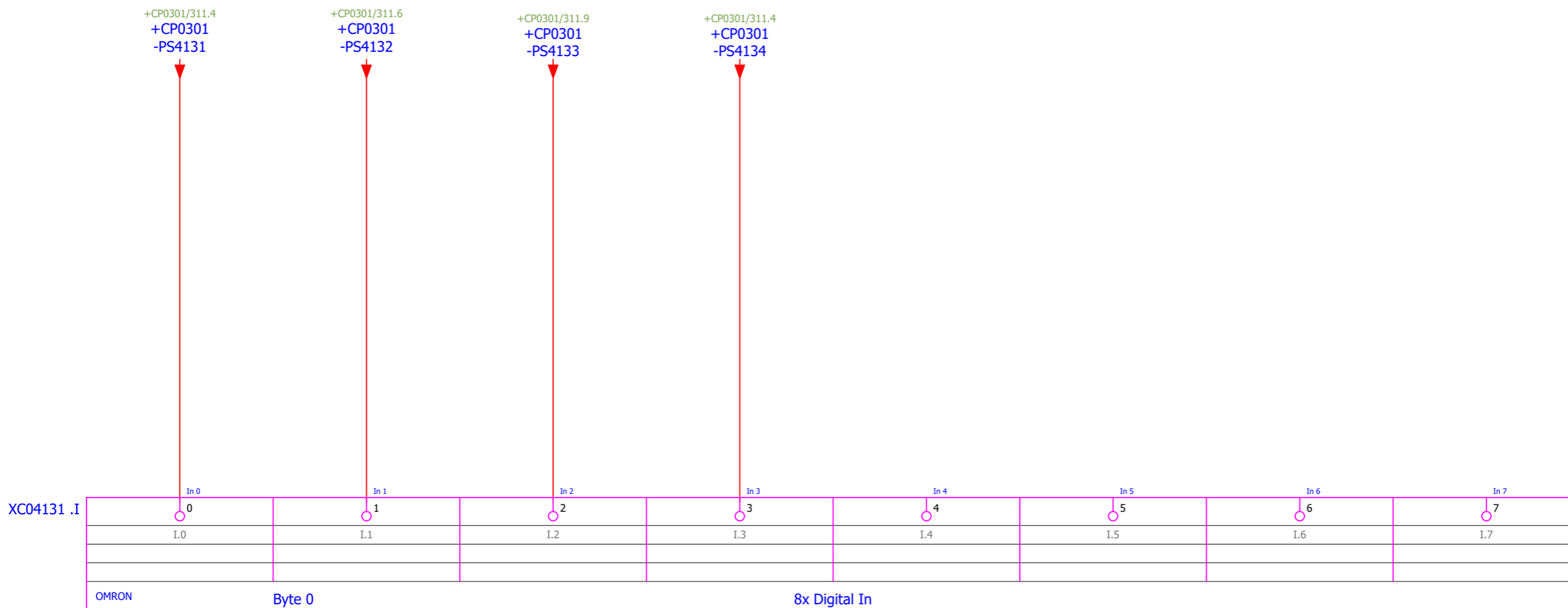

XC4131.0

